



# Greengate

## Passive Infrared Ceiling Mounted Low Voltage Occupancy Sensor

P/N 9850-000168-01



### RoHS

Model # OAC-P-0500  
Model # OAC-P-0500-R  
Model # OAC-P-1500  
Model # OAC-P-1500-R

### General Information

- Read all instructions on both sides of this sheet first
- Install in accordance with ALL local codes
- For indoor use only
- For Use with Greengate Switchpacks & Systems Only
- Do not run any Greengate Low Voltage Wiring in the same conduit as power conductors

### Specifications

#### Power Requirements:

- Input:
- 10-30 VDC from Greengate Switchpack or Greengate system. Maximum current needed is 25mA per sensor
- Output:
- Open collector output to switch up to ten Greengate Switchpacks.
  - BAS with Isolated Form C Relay (-R model)
  - Isolated Form C Relay Ratings: 1A 30 VDC/VAC

#### Operating Environment:

- Temperature: 32° F – 104° F (0° C – 40° C)
- Relative Humidity: up to 90% non-condensing

### Description

The OAC-P Ceiling Mount Low Voltage Occupancy Sensor is a Passive Infrared (PIR) motion sensing lighting control, used for energy savings and convenience. The sensor produces a Passive Infrared (PIR) motion sensing lighting control, used for energy savings and convenience. When motion is detected, the blue wire is electronically connected to the red wire, energizing the relay in the switchpack to turn ON the load. If vacancy is detected, the blue wire is disconnected from the red, causing the relay to open turning OFF the load. The red lead is 10-30 VDC supply, the black lead is common, and the blue is the relay control.

The sensor includes self-adaptive technology that continually adjusts to conditions by adjusting sensitivity and Time Delay in real-time.

### Coverage

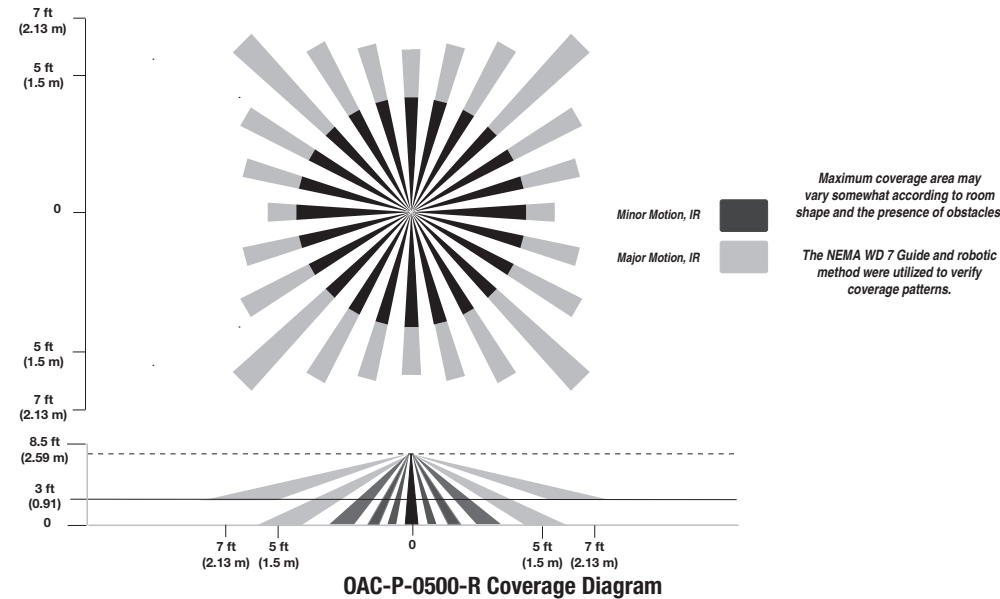
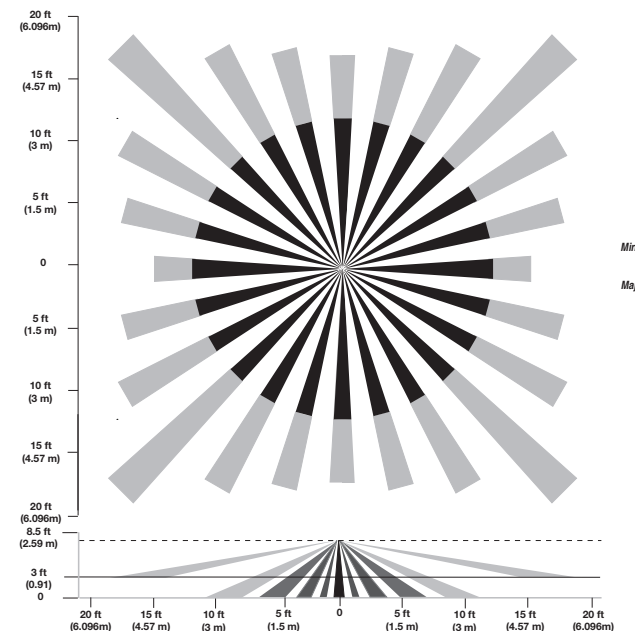

### Location

The maximum coverage area may vary somewhat according to room shape and the presence of obstacles. Follow the coverage diagram concerning major and minor motion coverage. The sensor must have a clear view of the area to be controlled. The sensor will not "see" through glass. Mounting height should not exceed 12 feet. Optimum mounting height is 8 to 10 feet. Avoid pointing into hallways. Mounting at fixture height is most effective. \*To prevent false activation, the sensor should be mounted away from the air supply duct a minimum of 4 to 6 feet.

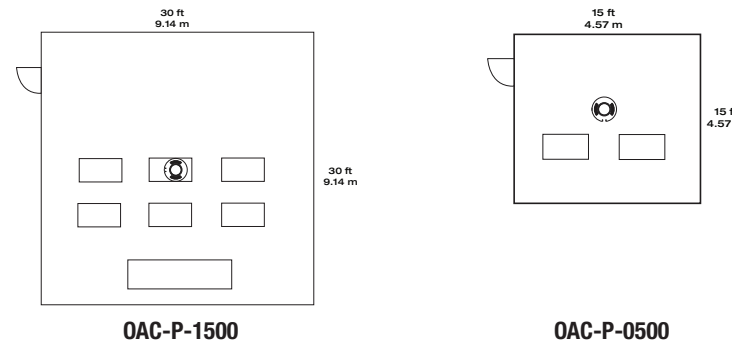

### Installation

The OAC-P sensor can be mounted to the ceiling, junction box, or round fixture with raceway.

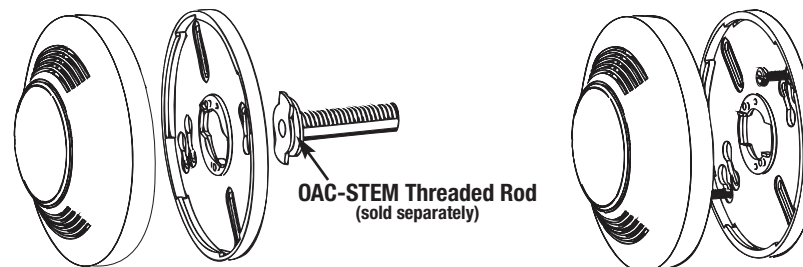

### Wiring

**CAUTION:** Before installing or performing any service on a Greengate system, the power **MUST** be turned OFF at the branch circuit breaker. According to NEC 240-83(d), if the branch circuit breaker is used as the main switch for a fluorescent lighting circuit, the circuit breaker should be marked "SWD". All installations should be in compliance with the National Electric Code and all state and local codes.

*NOTE REGARDING COMPACT FLUORESCENT LAMPS:* The life of some compact fluorescent lamps (CFLs) is shortened by frequent automatic or manual switching. Check with CFL and ballast manufacturer to determine the effects of cycling.

1. Make sure power is turned OFF at the branch circuit breaker.
2. Wire units as shown in wiring diagrams per applicable voltage requirements. (Use twist-on wire connectors for all connections) CAP ALL UNUSED WIRE LEADS.
3. Mount unit to ceiling, junction box, or round fixture with raceway.
4. Turn power back ON at the branch circuit breaker and wait 2 minutes for the unit to stabilize.
5. Make necessary adjustments. (See Checkout and Adjustments section)

#### One Sensor, One Switchpack

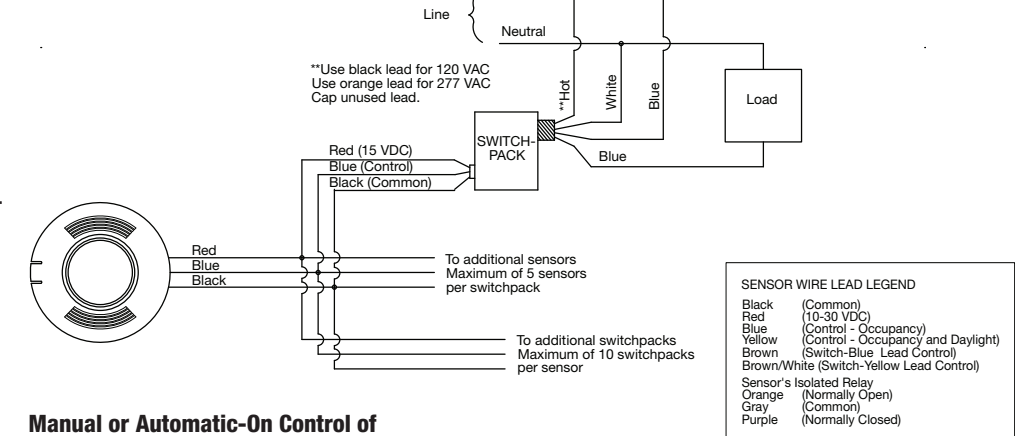

#### Manual or Automatic-On Control of Two Standard Switchpacks

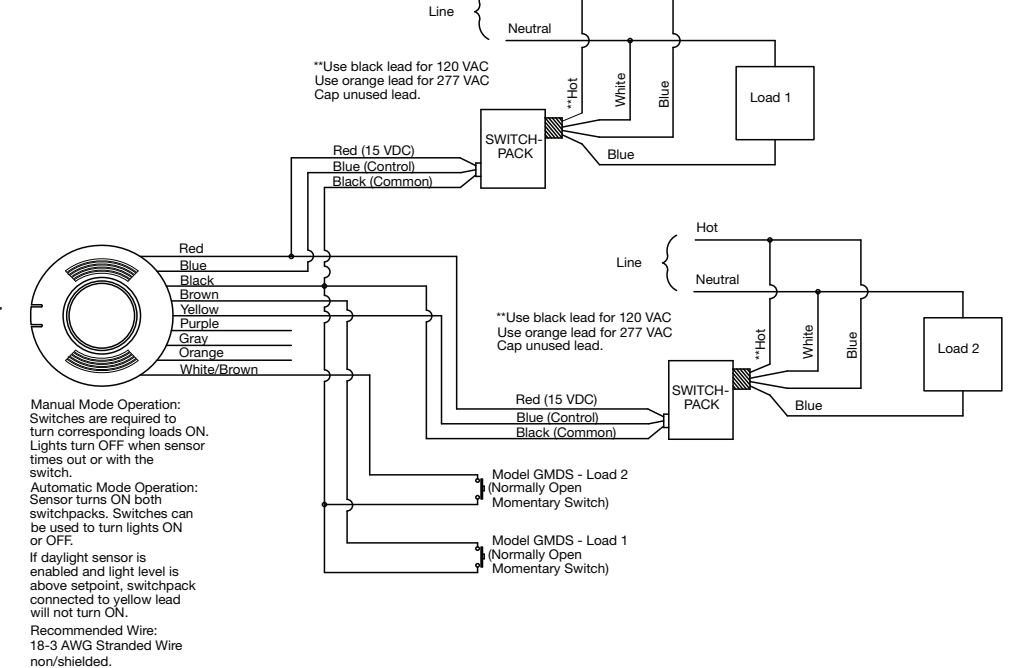

## DIP Switch Settings

### DIP Switch Legend

| DIP Switch | Time Delay |   | Activation      |              | PIR Sensitivity | Walk-Through Mode | LEDs            | Override | Sweep           | Full/Half Logic | HVAC/Tracking   | Zero Time Delay |
|------------|------------|---|-----------------|--------------|-----------------|-------------------|-----------------|----------|-----------------|-----------------|-----------------|-----------------|
|            | 1          | 2 | Risky 1<br>3    | Risky 2<br>4 |                 |                   |                 |          |                 |                 |                 |                 |
| Auto*      | ▼          | ▼ | Auto            | Auto         | Full            | Disable           | Enable          | Disable  | Disable         | Full            | Disable         | Disable         |
| 5 Minutes  | ▼          | ▲ | Manual          | Manual       | 50%             | Enable            | Disable         | Enable   | Enable          | Half            | Enable          | Enable          |
| 15 Minutes | ▲          | ▼ | (-R model only) |              | (-R model only) |                   | (-R model only) |          | (-R model only) |                 | (-R model only) |                 |
| 30 Minutes | ▲          | ▲ | (-R model only) |              | (-R model only) |                   | (-R model only) |          | (-R model only) |                 | (-R model only) |                 |

Default =

### Daylight Sensor Adjustment

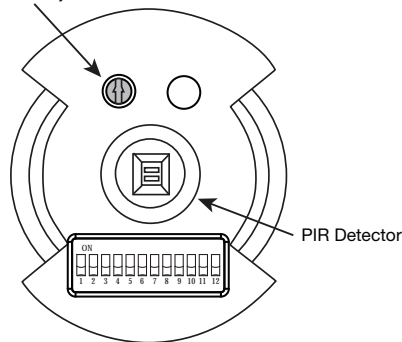

## Checkout and Adjustment

### LED Indicators Functionality

|                           | During Installer/Test Mode        | While in User Mode              |
|---------------------------|-----------------------------------|---------------------------------|
| <b>LED Flashing Speed</b> | LEDs will flash once per ¼ second | LEDs will flash once per second |
| <b>Duration</b>           | 10 minutes                        | 10 to 30 minutes                |

Adjustments should be made with the HVAC system ON. Use only insulated tools to make adjustments.

### Self-Adjust

Sensor is shipped in the Self-Adjust Mode. This applies to Time Delay and PIR sensitivity. In preparation for the Installer Test, the time delay is set to 15 seconds, after the sensor is installed, powered-ON and has stabilized, the unit will Time-out 15 seconds after the last motion detected. Coverage and sensitivity can be confirmed by watching the Passive Infrared (PIR) indicator LEDs on the front of the sensor, while moving around the room.

1. Walk around the room and monitor LEDs. LEDs should only turn ON for ¼ second with each motion. (If LEDs do not turn ON, go to Installer Adjustments - Sensitivity Adjustments Section)
2. Stand still six to eight feet away from the sensor for five seconds. LEDs should not turn ON. (If any LED turns ON, note LED and go to Installer Adjustments – Sensitivity Adjustment section)
3. Walk outside the room and wait 15 seconds for the lights to turn OFF. (If lights do not turn OFF go to Installer Adjustments Section)
4. Re-enter the room to activate sensor. (If lights do not turn ON go to Troubleshooting Section)
5. The unit will remain in Test Mode for 10 minutes then automatically exit Test Mode and go for 10 min. Time Delay User Mode setting.

**Note:** To place into Test Mode, toggle DIP Switch 10 out of its current position, wait 3 seconds, and then back in to its original position. To force into 10 min User Mode move Dip Switches 1 and 2 down. (If DIP Switches 1 and 2 are already down, toggle DIP Switch 1 out of its current position, wait 3 seconds, and then back to its original position) While in Test Mode, the LEDs will flash once per 1/4 second.

## Installer Adjustments

### Sensitivity Adjustments

#### PIR Sensitivity

1. Stand in different areas of the room and wave your hands.
2. If the Red LED does not turn ON, check for any obstructions.
3. Stand still six to eight feet away from sensor for five seconds. LED should not turn ON.
4. If Red LED turns ON without motion or is constantly ON adjust PIR sensitivity to 50% by moving DIP Switch 5 up.

#### Field-of-view outside the space

1. Adjust PIR sensitivity to 50% by moving DIP Switch 5 up.

#### Daylight Adjustments (-R Model Only 0 to 300 foot-candles)

If this feature is not needed, leave the light level at maximum (fully clockwise).

The Daylighting feature prevents the lights from turning ON when the room is adequately illuminated by natural light. If there is enough light in the room regardless of occupancy, the sensor will hold the lights OFF. If there is not enough light in the room, the sensor will allow the lights to turn ON when occupied.

### Full and Half Logic Modes (See DIP Switch legend):

In both Full and Half Logic modes, lights connected to the yellow control lead will not turn ON upon occupancy activation, should the ambient light level exceed the preset foot-candle level.

#### After activation:

Full Logic Mode - should the ambient light level exceed the preset foot-candle level, the lights connected to the yellow control lead will turn OFF. The lights will remain OFF, until the ambient light level falls below the set point.

Half Logic Mode – the output state of the yellow control lead will not change with ambient light changes, after occupancy activation. If the amount of natural light available rises above the setpoint, the daylight sensor will not turn the lights OFF while occupancy is being detected.

**Note:** Set the light level when the ambient light is at the level where no artificial light is needed. In order for this feature to function, the yellow control lead must be wired.

1. With the load ON, put the sensor into Test Mode. To place into Test Mode, toggle DIP Switch 10 out of its current position, wait 3 seconds and then back in to its original position.
2. Set DIP Switch 10 to Full or Half Logic Mode.
3. Set the Light level to Minimum (fully CCW).
4. Leave the room and let the sensor Time-out so lights are OFF. Enter the space and lights should remain OFF.
5. Make sure not to block the sensor from the daylight source and adjust the light level potentiometer CW in small increments until the lights are ON. (Pause 5 seconds between each adjustment)
6. Once the lights are ON, the load connected to the sensor will not turn ON if light levels are above the current illumination.

### Time Delay Adjustments

People who remain very still for long periods of time may need a longer Time Delay than the default setting of 10 minutes. As long as Auto is enabled, the sensor will respond to each pair of False-offs with no normal OFF in between, by alternately making slight adjustments to either Time Delay (by 2 minute increments) or sensitivity, so there should be no need for manual adjustment. If manual adjustment is desired, refer to Time Delay settings in DIP Switch legend.

Reset sensor Time Delay to factory settings by moving DIP Switches 1 and 2 down. (If DIP Switches 1 and 2 are already down, toggle DIP Switch 10 out of its current position, wait 3 seconds, and then back to its original position)

### Automatic Mode

In Automatic-ON Mode, the lights turn ON when a person enters the room. If optional momentary low voltage switches are used along with Automatic-ON Mode, activating the switch(es) while the load is ON turns the load OFF. When the load is turned OFF manually, as long as the sensor continues to detect occupancy the loads stay OFF. After the Time Delay expires, the lights stay OFF and the sensor goes back to Automatic-ON Mode. For wiring information for the optional momentary low voltage switch(es), please see the wiring section of the installation instructions.

### Manual Mode (-R Model Only)

In Manual-ON Mode, the optional momentary low voltage switch(es) is required to turn the load(s) ON. Once activated the sensor will maintain the lights ON until motion ceases and the Time Delay expires. While the room is occupied the BAS relay remains active. After the Time Delay expires, the load(s) will automatically be turned OFF and the switch(es) must be used to turn the load(s) ON unless there is motion detected within the 10 second re-trigger period.

### Lighting Sweep Option

If selected, this DIP Switch option forces an initial 60 second delay upon “power up” to prevent false activation in buildings with computer control systems.

1. Move DIP Switch 9 up. If not selected (Dip Switch 9 down), upon initial “power up” or restoration of power the sensor will force the lights ON no matter the state of occupancy.

### HVAC/Tracking Mode (-R model only)

If selected, Tracking Mode allows the load connection to the Form C relay to follow the state of the sensor’s blue lead. HVAC Mode allows the load connected to the Form C relay to remain ON when the lights are turned OFF manually. Applications may include keeping the room at a desired temperature while giving a presentation and the lights are OFF.

### Zero Time Delay Mode

In Zero Time Delay Mode, the output is actuated for one second to signal another device that the space being monitored is occupied. Applications may include the use of a lighting control system to manage the delay of the lighting deactivation. Please see the wiring diagram section for wiring details.

When in Zero Time Delay Mode and Tracking Mode the load connected to the Form C relay shall follow the state of the sensor’s blue lead (zero Time Delay for the form C relay).

When in Zero Time Delay Mode and HVAC Mode, the load connected to the Form C relay remains ON for the standard Time Delay.

### Override

The Override setting allows the lights to remain ON in the unlikely event of sensor failure.

1. Move DIP Switch 8 up.
- While in Override Mode, the optional low voltage momentary switch(es) will toggle the lighting load(s).

## Troubleshooting

| Issue  | Possible Causes   | Suggestions   |
|--|---|---|
| <b>Lights Will Not Turn ON automatically</b>   | Wall Switch OFF   | Turn Wall Switch ON.  |
|  | If low voltage switch option is used, lights may have been turned-off manually. | Press low-voltage switch.   |
|  | Daylight Feature Enabled  | If all lights are required to turn ON adjust DIP Switch 10 and/or daylight potentiometer  |
|  | Power interruption  | Check incoming voltage and/or wiring  |
| <b>Lights Will Not Turn ON manually</b>  | Daylight Feature Enabled  | If all lights are required adjust DIP switch 10 and/or daylight potentiometer.  |
|  | Power interruption  | Check incoming voltage and/or wiring  |
| <b>If lights will still not turn ON, set sensor to override mode and call Technical Services at 1-800-553-3879</b> |   |   |
| <b>Lights Will Not Turn OFF automatically</b>  | Override  | Make sure sensor is not in Override Mode (DIP Switch 8 up).   |
|  | Sensor installed close to an air vent   | Sensors should be installed minimum 4 - 6 feet away from any air vent and out of path of heavy airflow.   |
|  | Sensor installed close to indirect lighting.                                    | Sensors should be mounted away from indirect lighting.  |
|  | Self-adjust   | It may be possible for the unit to have self-adjusted the time delay to a 30 minute delay. If the lights do not turn OFF after 30 minutes follow next step. |
|  | 30 Minute Delay   | Maximum time delay is 30 Minutes. Check DIP Switches to verify DIP Switch settings. If lights do not turn OFF at the set time delay, check next step.       |
|  | PIR activated by heat source other than occupant                                | Move DIP Switch 5 up.   |
| <b>Lights Will Not Turn OFF manually</b>   | Bypass  | Check wiring to make sure sensor or switchpack are not bypassed.  |
|  | Override  | Make sure sensor is not in Override Mode (DIP Switch 8 up).   |
| <b>If lights will still not turn OFF, call Technical Services at 1-800-553-3879</b>                                |   |   |

## Warranties and Limitation of Liability

Please refer to [www.cooperlighting.com](http://www.cooperlighting.com) under the Legal section for our terms and conditions.