

COOPER LIGHTING SOLUTIONS - SURE-LITES®

DESCRIPTION

The StairLite 2 is designed to satisfy all stairwell lighting requirements in one easy to install package. The StairLite 2 is a surface mounted, two lamp fluorescent lighting fixture that incorporates an integrally mounted ultrasonic motion detector, a system display panel, and an optional battery backup. Either one or both lamps can be controlled by the motion sensor. Bi-level lamp operation is standard so that one lamp will remain on constantly for security and the motion detector will activate the second lamp as needed to significantly reduce the operating cost. The StairLite 2 is designed for use in stairwells or any other areas of a building that have a low occupancy level.

| | | |
|-------------|--|------|
| Catalog # | | Type |
| Project | | |
| Comments | | Date |
| Prepared by | | |

SPECIFICATION FEATURES

Electrical

- Choice of Input Voltage: 120 or 277 VAC, 60Hz
- T8 Fluorescent Lamp Technology
- Field Adjustable Bi-Level or Dual Lamp operation
- Time Delay: Adjustable between 15 sec. to 40 min.
- Sensitivity: Adjustable Settings
- Solid-state Status Indicator Display system with an AC power indicator
- Two, single lamp Program Rapid Start Ballasts
- Sealed, maintenance-free nickel cadmium battery

Housing Construction

- Formed 20 gauge steel housing and cover plate construction
- Durable powder coat white finish
- Variety of electrical and mounting knockouts for easy installation
- Wall and Ceiling* Mountable
- High impact acrylic lenses

* Consult Factory

Code Compliance

- UL 924 Listed
- Life Safety NFPA 101
- NEC/OSHA
- Most State and Local Codes

Warranty

- Fixture: 1 Year
- Battery: 15-Year, Pro-Rata



STL2 STAIRLITE 2

STEEL
SURFACE MOUNT
SEALED NICKEL
CADMIUM BATTERY
T8 LAMPS
EMERGENCY LIGHTING

TOTALLY PREDICTABLE
RELIABILITY

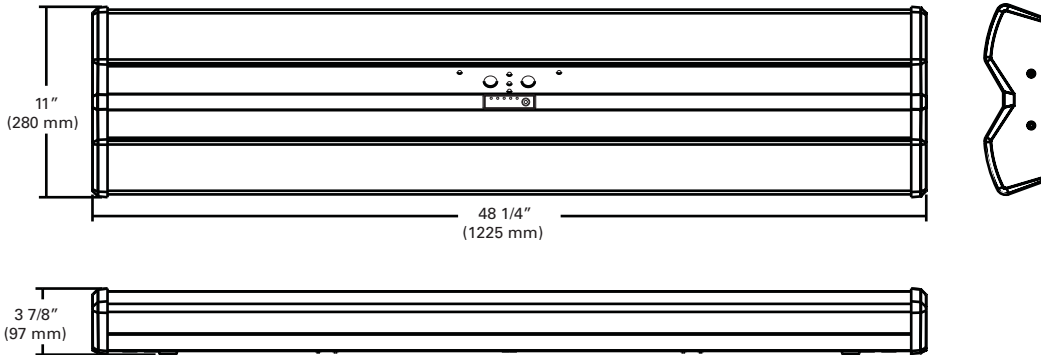

ORDERING INFORMATION

| | | | |
|------------------------------------|---|--------------------------------------|---|
| Family STL2: StairLite 2 | Operation 4: AC Only 5: Self Powered | Lamp = (2) 4' Lamps F032T8 | Voltage = 120 VAC 7: 277 VAC |
|------------------------------------|---|--------------------------------------|---|

ENERGY DATA

(1) 32WT8

Input Power:
120V = 44W
277V = 42W

Input Current (Max.):
120V = .37A
277V = .15A

Power Factor:
120V = .98
277V = .99

(2) 32WT8

Input Power:
120V = 73W
277V = 71W

Input Current (Max.):
120V = .12A
277V = .05A

Power Factor:
120V = .92
277V = .92

Input Current (Max.):
120V = .61A
277V = .25A

Power Factor:
120V = .99
277V = .99

Lamps Off
Input Power:
120V = 14W
277V = 13W

Input Current (Max.):
120V = .12A
277V = .05A

Power Factor:
120V = .92
277V = .92

TECHNICAL DATA**Ultrasonic Motion Detector**

The ultrasonic motion detector is designed to illuminate the lamp(s) when the stairwell is occupied. It includes a fully automatic test circuit to ensure the system is functioning properly. The motion detector sensitivity is adjustable. See Area of Sensor Recognition. In addition, the length of time in which the lamps remain on can be adjusted from 15 seconds to 40 minutes. A lamp will remain illuminated for a minimum of 90 minutes during a power failure.

Status Indication

The StairLite 2 features a solid state Status Indicator Display System that ensures system reliability and function at a glance. It consists of a test switch (battery back-up fixtures only), an AC indicator and an LED display in the event of ballast or ultrasonic motion detector failure.

Battery Backup

The battery backup will provide 580 lumens of light for at least 90 minutes in the event of a power failure. Illumination is provided by one lamp while the other is held in reserve; in the event the first lamp fails, the second lamp will energize to provide emergency illumination.

Housing Construction

Rugged 20 gauge steel is formed to create both the body and cover plates. Each is then finished in a long-lasting, durable white powder coat finish. Numerous knockouts for both electrical connections and mounting make installation fast and easy on virtually any surface.

Lamp and Ballast

The StairLite 2 utilizes energy efficient T8 fluorescent lamp technology with electronic ballasts.

Warranty

The Sure-Lites StairLite 2 is backed by a firm one year warranty against defects in material and workmanship for the entire fixture. Maintenance-free, long-life, sealed nickel cadmium batteries carry a fifteen-year pro-rata warranty.

Area of Sensor Recognition