

EBPLEDC1HV-20W

IB505083EN

CLP-049-336

SURE-LITES

Installation Instructions for the Sure-Lites LED Emergency Driver

WARNING

Risk of Fire/Electric Shock

If not qualified, consult an electrician.

WARNING

Risk of Electric Shock

Disconnect power at fuse or circuit breaker before installing or servicing.

IMPORTANT SAFEGUARDS

WHEN USING ELECTRICAL EQUIPMENT, BASIC SAFETY PRECAUTIONS SHOULD ALWAYS BE OBSERVED INCLUDING THE FOLLOWING.

1. READ AND FOLLOW ALL SAFETY INSTRUCTIONS

2. Do not use outdoor
3. Do not use near gas or electric heaters.
4. Do not use in air handling heated air outlets, sealed and gasketed fixtures, wet or hazardous location fixtures.
5. Do not let power supply cords touch hot surfaces.
6. Do not use this equipment for other than the intended use.
7. The use of accessory equipment not recommended by the manufacturer may cause an unsafe condition. Servicing should only be performed by qualified service personnel.
8. Equipment should be mounted in locations and at heights where it will not readily be subjected to tampering by unauthorized personnel.
9. Prior to installation, battery connector must be open to prevent high battery drain on the unit .
10. This product is for use with an emergency LED lighting load and supplies nominally 20.0 W of power with a voltage 125 - 200 Vdc in emergency mode for a minimum of 90 minutes.
11. This product is suitable for use in damp locations where the ambient temperature is 0°C minimum, +50°C maximum. Product is also suitable for installation in sealed and gasketed fixtures, Product is not suitable for heated air outlets and wet or hazardous location. Maximum allowable case temperature is 65°C. See unit label for measurement location.
12. To avoid electrical shock, please disconnect normal and emergency power supplies, and battery connector of the emergency driver before servicing.

13. This emergency driver is for factory or field installation on top of or remote from the fixture.
14. For Canadian application the output terminals should be in compliance with the accessibility requirement of the Canadian electric Code.
15. This device complies with part 15 of the FCC Rules. Operation is subject to the following two conditions: (1) this device may not cause harmful interference, and (2) this device must accept any interference that may cause undesired operation.
16. This product's chassis must be grounded.
17. Unswitched AC power source of 120 VAC through 277 VAC is required.
18. The battery is sealed, non-maintenance, and is not replaceable in the field. Please contact manufacturer for information on service. Do not attempt to service the battery.
19. Install in accordance with National Electric Code and local regulatory agency requirements. Installation is to be performed only by qualified personnel.
20. DO NOT EXCEED TOTAL OUTPUT RATING of source power equipment.



Ni - Cd

THIS PRODUCT CONTAINS A RECHARGEABLE NICKEL-CADMIUM BATTERY. THE BATTERY MUST BE RECYCLED OR DISPOSED OF PROPERLY.

Installation Instructions for the Sure-Lites LED Emergency Driver



CAUTION: DO NOT JOIN CONVERTER CONNECTOR UNTIL INSTALLATION IS COMPLETE AND AC POWER IS SUPPLIED TO THE EMERGENCY DRIVER.

NOTE: Make sure the necessary branch circuit wiring is available. An unswitched source of power is required. The emergency driver must be fed from the same branch circuit as the AC driver.

This product is suitable for field installation with suitable LED loads including LED luminaires, DC voltage driven LED replacements for fluorescent lamps and others. There are 4 checks to determine if your luminaire is eligible for field installation.

1. Ensure the LED load's rated power is greater than or equal to the power output of this emergency LED driver. This is to ensure that this emergency product will not produce more power than the LED load can handle, thus ensuring that the LED load will not be damaged when the system is in the emergency mode.
2. Verify that the forward voltage of the luminaire's LED array is within the limits of this emergency LED driver. The forward voltage of the LED array is commonly designated as Vf and should be found on the luminaire markings, in the luminaire specifications, or imprinted directly on the LED arrays. If multiple LED arrays are to be driven, verify that the total forward voltage is within the limits of this product. Using a voltage meter, it may be possible to directly measure the voltage across the LED arrays when operating from the AC driver.
3. Ensure the output current of the LED driver does not exceed 2.0 Amps. This is the current into the blue wire.
4. Ensure there will be sufficient light output in the end application. Estimate the egress lighting illumination levels by doing the following:
 - a. Find the efficacy of the LED load. This can be given by the luminaire manufacturer. This number will be given in lumens per watt (lm/w). It is the installer's responsibility to validate the luminaire manufacturer's efficacy data. This can be accomplished by direct measurement, by review of independent 3rd party test data (UL, ETL, etc.), accessing a public database of 3rd party data (such as Design Lights Consortium, www.designlights.org), or other comparable means.
 - b. Lumens can be calculated by multiplying the output power of the emergency LED driver by the efficacy of the LED load. In many cases the actual lumen output in emergency mode will be greater than this calculation gives, however it will provide a good estimate for beginning the lighting design of the system.
 - c. Using the results of this calculation and industry standard lighting design tools, calculate the anticipated illumination levels in the path of egress.

Lumens In Emergency Mode = Lumens per Watt of

Fixture * Output Power of Chosen Product

$$\text{(Lumens)} = \text{(lm/W)} * \text{20 (W)}$$

NOTE: This product has been designed to reliably interface with a wide selection of LED loads and is electrically compatible with every simple LED array that meets criteria 1 and 2 above. However, compatibility cannot be guaranteed with all current and future LED systems. Compatibility testing of the end-use system is suggested. Please contact the factory with any questions.

INSTALLING THE EMERGENCY DRIVER

1. Disconnect AC power from the LED luminaire.
2. Mount the emergency LED driver by the mounting tabs using the supplied screws. The luminaire's installation instructions may provide guidance on the recommended mounting location.
 - > **Mounting Height:** This product meets or exceeds the NFPA minimum light requirements with all loads, down to the smallest rated lamp load, at heights up to 7.17ft (2.2m). Many factors influence emergency illumination levels, such as the lamp load selected, luminaire design, and environmental factors therefore end use verification is necessary. For field installations, when the attached luminaire is mounted at heights greater than 7.17ft (2.2m), the level of illumination must be measured in the end application to ensure the requirements of NFPA 101 and local codes are satisfied.
 - > **Remote Mounting:** The emergency driver may be remote mounted from the luminaire. If used in conjunction with an AC driver, this distance is up to half the distance the AC driver manufacturer recommends remote mounting the AC driver from the LED Load. If used without an AC driver, consult factory. The test button indicator light may also be remote mounted. **CAUTION:** Remote mounting can result in reduced power output. For remote mounting more than five feet from the luminaire, please consult factory to determine the minimum necessary wire gauge.
3. Mount the supplied test button indicator light in a location that is visible and accessible by maintenance personnel. The test button indicator light mounts through a 1/2" hole which may need to be made in the luminaire or could come pre-punched by the luminaire supplier.
4. Wire the test switch per wiring diagrams provided on these instructions.
5. If wired correctly, the test button indicator light should be ON when AC power is supplied to the fixture, and the converter connector is closed indicating that the emergency driver battery is charging. After installing, mark with the "PUSH TO TEST" and "CHARGING INDICATOR LIGHT" labels.

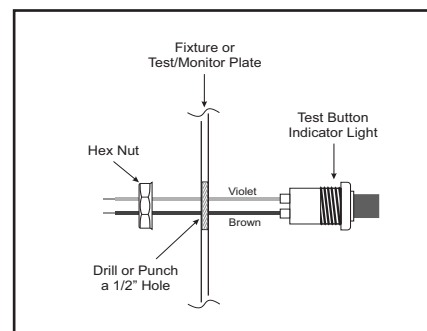

Installation Instructions for the Sure-Lites LED Emergency Driver

6. Select the appropriate wiring diagram to connect the emergency driver to the AC driver and LED load. Make sure all connections are in accordance with the National Electrical Code and any local regulations.
7. After installation is complete, supply AC power to the emergency driver and join the unit engage connector.
 - > At this point, power should be connected to both the AC driver and the emergency driver, and the test button indicator light should illuminate indicating the battery is charging.
 - > A short-term discharge test may be conducted after the emergency driver has been charged for one hour. Charge for 24 hours before conducting a long-term discharge test. Refer to OPERATION.
8. In a readily visible location, attach the label "**CAUTION - This Unit Has More Than One Power Connection Point. To Reduce The Risk Of Electric Shock, Disconnect Both The Branch Circuit-Breakers Or Fuses And Emergency Power Supplies Before Servicing.**"

NOTE: After installation, it will be necessary to measure the egress lighting illumination levels to ensure it complies with national, state, and local code requirements.

OPERATION

During normal operation AC power is applied, the test button indicator light is illuminated, indicating that the battery is being charged. When power fails, the emergency LED driver automatically switches to emergency power (internal battery), operating the LED load for a minimum of 90 minutes. When AC power is restored, the emergency driver returns to the charging mode.

MAINTENANCE

Although no routine maintenance is required to keep the emergency driver functional, it should be checked periodically to ensure that it is working. The following schedule is recommended:

1. Visually inspect the test button indicator light monthly. It should be illuminated.
2. Test the emergency operation of the fixture at 30-day intervals for a minimum of 30 seconds. The LED load should operate at reduced illumination.
3. Conduct a 90-minute discharge test once a year. The LED load should operate at reduced illumination for at least 90 minutes.

! REFER ANY SERVICING INDICATED BY THESE CHECKS TO QUALIFIED PERSONNEL !

WIRING DIAGRAM

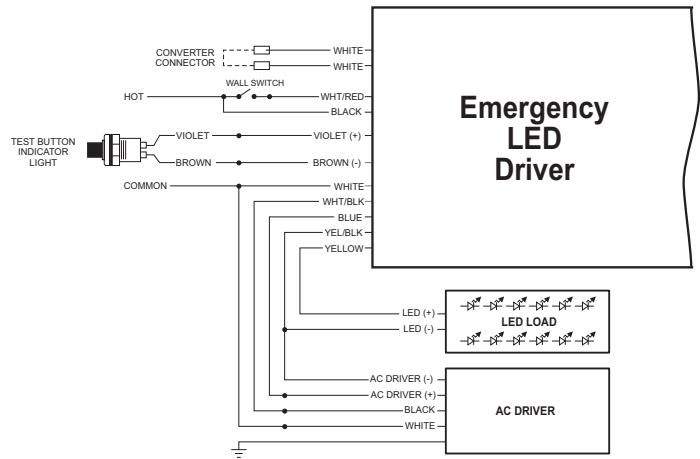

EMERGENCY DRIVER AND AC DRIVER MUST BE FED FROM THE SAME BRANCH CIRCUIT.

TYPICAL SCHEMATICS ONLY. MAY BE USED WITH OTHER DRIVERS.
CONSULT THE FACTORY FOR OTHER WIRING DIAGRAMS.

NOTE: The converter connector must be connected for the AC driver to operate normally.

Cooper Lighting Solutions
1121 Highway 74 South
Peachtree City, GA 30269
P: 770-486-4800
www.cooperlighting.com

© 2020 Cooper Lighting Solutions
All Rights Reserved
Tous droits réservés
Todos los derechos reservados

Printed in USA
Imprimé aux États-Unis
Impreso en los EE. UU.
Publication No. IB505083EN
08/10/2020 44229193041

Cooper Lighting Solutions is a registered trademark. All trademarks are property of their respective owners.

Cooper Lighting Solutions est une marque de commerce déposée. Toutes les autres marques de commerce sont la propriété de leur propriétaire respectif.

Cooper Lighting Solutions es una marca comercial registrada. Todas las marcas comerciales son propiedad de sus respectivos propietarios.

Product availability, specifications, and compliances are subject to change without notice.

La disponibilité du produit, les spécifications et les conformités peuvent être modifiées sans préavis.

La disponibilidad de productos, las especificaciones y los cumplimientos están sujetos a cambio sin previo aviso.