

INSTALLATION MANUAL FOR REMOTE POWER SYSTEM: LUMASPORT 8 LIGHT HEAD LUMASPORT 8 PRISM LIGHT HEAD

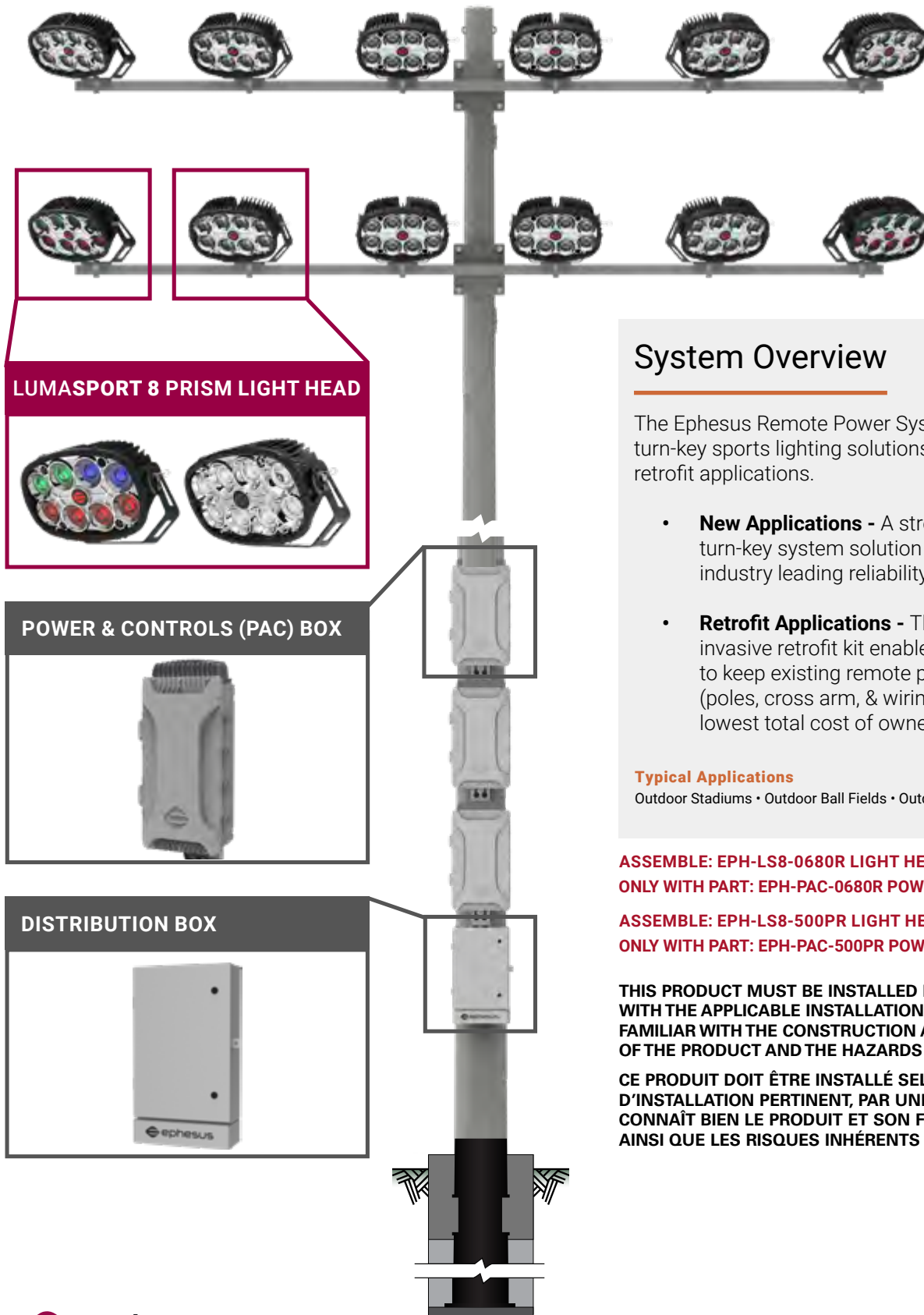

System Overview

The Ephesus Remote Power System delivers full turn-key sports lighting solutions for both new and retrofit applications.

- **New Applications** - A streamlined full turn-key system solution backed with industry leading reliability and performance.
- **Retrofit Applications** - The minimally invasive retrofit kit enables the opportunity to keep existing remote power infrastructure (poles, cross arm, & wiring) providing the lowest total cost of ownership.

Typical Applications

Outdoor Stadiums • Outdoor Ball Fields • Outdoor Multi-Event Spaces

ASSEMBLE: EPH-LS8-0680R LIGHT HEAD

ONLY WITH PART: EPH-PAC-0680R POWER AND CONTROLS BOX

ASSEMBLE: EPH-LS8-500PR LIGHT HEAD

ONLY WITH PART: EPH-PAC-500PR POWER AND CONTROLS BOX

THIS PRODUCT MUST BE INSTALLED IN ACCORDANCE WITH THE APPLICABLE INSTALLATION CODE BY A PERSON FAMILIAR WITH THE CONSTRUCTION AND OPERATION OF THE PRODUCT AND THE HAZARDS INVOLVED

CE PRODUIT DOIT ÊTRE INSTALLÉ SELON LE CODE D'INSTALLATION PERTINENT, PAR UNE PERSONNE QUI CONNAÎT BIEN LE PRODUIT ET SON FONCTIONNEMENT AINSI QUE LES RISQUES INHÉRENTS





WARNINGS AND CAUTIONS

Failure to strictly adhere to the warnings and cautions as well as the installation instructions may result in serious personal injury or property damage.

Before You Begin

Read and understand this entire manual and any additional site-specific installation documents before attempting to assemble, install, or operate the luminaire. If you have any questions regarding the product or installation, contact Cooper Lighting Customer Service at 1-800-573-3600. The most up to date version of this installation manual can always be found at ephesuslighting.com.

Follow all warning and cautions outlined here as well as any local safety procedures.

- All electrical work must conform to National Electrical Code (NFPA 70), IEEE Emerald book, and all applicable local codes and ordinances.
- Ensure the capacity of the existing power distribution system meets the load requirements for the new installation, including inspection of wiring integrity and confirm the branch circuit voltage matches the voltage of the lighting equipment.
- See fixture specification sheet for weight and wind loading (EPA) data. Supporting and mounting structures must comply to industry standard capacity requirements and comply with applicable regulatory and safety codes.
- Electrical distribution systems must comply with all applicable regulatory and safety codes.
- In harsh settings where the system is subjected to factors such as extreme temperatures, high corrosion, hurricanes, or lightning, always follow local codes and additional protocols to ensure the cabling and other system components can withstand the environmental stress for the life of the system.
- DO NOT make or alter any open holes in the luminaire. Do not modify the luminaire, internal wiring, or fixture mounting features. Opening or modifying the luminaire or bracket will void the warranty.
- Use Personal Protective Equipment including hardhats, safety glasses, reflective vests, electrical safety gloves, fall protection equipment, and safety toe boots during installation, operation, and maintenance of luminaire.
- Verify compliance with local standards to prevent access to the area below where installation activities are occurring to prevent injury from accidental drops of fixtures, tools or hardware.

Storage

Store luminaires in a clean, dry place, protected from dirt, water, and sunlight prior to installation. See Table 1 for required storage and operating conditions:

Storage Temperature	Operating Temperature	Humidity
-40°C to +75°C (-40°F to 167°F)	-40°C to +40°C (-40°F to 104°F)	5% to 95% non-condensing

Table 1. Storage and Operating Conditions



Risk of Fire, Electrical Shock, Cuts or other Casualty Hazards - Installation and maintenance of this product must be performed by a qualified electrician. This product must be installed in accordance with the applicable installation code by a person familiar with the construction and operation of the product and hazards involved.



Risk of Fire and Electric Shock - Make certain power is OFF before starting installation or attempting any maintenance. Disconnect power at fuse or circuit breaker.



Risk of Fire - Refer to product label for specific minimum supply conductor requirements.



Risk of Burn - Disconnect power and allow fixture to cool before handling or servicing.



Risk of Personal Injury - Fixture may become damaged and/or unstable if not installed properly.

DISCLAIMER OF LIABILITY: Cooper Lighting Solutions assumes no liability for damages or losses of any kind that may arise from the improper, careless, or negligent installation, handling or use of this product.

NOTICE: Green ground wire provided in proper location. Do not relocate.

ATTENTION Receiving Department: Note actual fixture description of any shortage or noticeable damage on delivery receipt. File claim for common carrier (LTL) directly with carrier. Claims for concealed damage must be filed within 15 days of delivery. All damaged material; complete with original packing must be retained.

APPLICATIONS: This lighting fixture should not be used in area of limited ventilation or inside high ambient temperature enclosures. It must be stored in a dry location before installation. Do not expose lighting fixture to rain, dust or other environmental conditions prior to installation. Best results will be obtained if installed and maintained according to the following recommendations.



Power Supply

Ephesus LED light heads are not traditional metal halide lights; they are high-tech, new-generation solid-state devices. To protect your valuable investment, ensure the the supply of electrical power is clean and stable with no spikes or sags.

The power transformer feeding the site electrical distribution system must be a three-phase, four-wire wye configuration or a single-phase configuration. An ungrounded delta configuration is **NOT** an approved power supply. If any other supply transformer configuration is present, notify Cooper Lighting before proceeding with installation.

All issues with supply power must be corrected before light heads are installed. Failure to use an approved supply power configuration may result in equipment damage.



LumaSport Remote Light Heads and PAC Boxes must have matching power configurations as specified in the cat logic. Do NOT install Light Head on a PAC Box that has a different power rating. Failure to properly match PAC Box and Light Head can cause damage. See guide below for how many light heads are supported by each PAC.

	QUANTITY OF FIXTURES PER POLE																							
LUMASPORT 8	1	2	3	4	5	6	7	8	9	10	11	12	13	14	15	16	17	18	19	20	21	22	23	24
QUANTITY OF PAC BOXES	1 PAC Box				2 PAC BOXES				3 PAC BOXES				4 PAC BOXES				5 PAC BOXES				6 PAC BOXES*			
QUANTITY OF DISTRIBUTION BOXES	1 DISTRIBUTION BOX																							

	QUANTITY OF FIXTURES PER POLE					
LUMASPORT 8 PRISM	1	2	3	4	5	6
QUANTITY OF PAC BOXES	1 PAC BOX		2 PAC BOXES		3 PAC BOXES	
QUANTITY OF DISTRIBUTION BOXES	1 DISTRIBUTION BOX					

Note: 1 qty. Distribution Box can support 6 qty. PAC Boxes.
*use (-XL)



Power Quality

Follow proper grounding methods. The electrical system must be properly grounded for power electronics in accordance with IEEE Emerald Book, including using equipment grounding conductors. Metallic conduits are **NOT** an acceptable grounding method for Cooper Lighting LED lighting systems. Power must also be phase balanced. If you are not sure if your power system is grounded or load balanced, **DO NOT** install the luminaire and contact a licensed electrician for information on proper grounding and balancing methods as required by the National Electrical Code and IEEE standards.



Surge Protection

Installation of surge protection is recommended in power distribution systems that feed LED sports lighting. Failure to protect electrical circuits from surges may result in damage to fixtures.



Branch Circuits

Branch power circuits feeding luminaires shall have a measured voltage of within 3% of nominal voltage with no sags, swells, or transients. When circuiting power to luminaires, load balance all circuits. See fixture specification sheet for power characteristic data.



Voltage Configuration

Before installing luminaires, verify that the fixture model number has the correct voltage configuration for your application. See fixture specification sheet for acceptable branch circuit voltage. Failure to confirm proper configuration may result in injury damage to fixtures.



WARNING

Failure to confirm proper configuration may result in injury or fixture damage.

IF YOU NEED CUSTOM SYSTEM COMPONENTS OR SERVICES PLEASE CONTACT EPHEBUS:

WWW.COOPERLIGHTING.COM/GLOBAL/CONTACT-US/EPHEBUS



- POLES
- CROSS ARMS
- DROP CABLES
- FOUNDATION DESIGN
- LIGHTING DESIGN



Required Tools and Materials

- 3/16in Hex driver
- 9/16in Socket w/ driver
- 15/16in Socket w/ driver
- 1-1/4in Socket w/ driver
- Moisture resistant butt splice connectors sized for 16-14 AWG and crimping tool. 2X per light head with quick clamp (Molex Perma-Seal # 191640483, 3M moisture resistant # 62-NBM-A, or equivalent) Heat source may be required.
- Socket wrenches and/or crescent wrenches sized to fit mounting hardware
- Ephesus Laser Aiming Kit (if applicable)

Light Head Electrical Performance Data

Product	Drive Current	DC Voltage	Light head Power (Driver Output Power)
EPH-LS-08-0680R	2.35 A	285 VDC	680 W

* Light head cannot be powered independently from the PAC Box
 * 14 AWG, 600V wire required. Rated and installed per electrical standard (contractor Supplied)
 * 200ft Max separation from PAC Box
 * Electrical System (Light Head, PAC Box, Distribution Box) must be grounded per electrical standard
 **This is the power to the light head - for system input power, see sheet 13 of the remote power specification sheet for the PAC box electrical performance data*

LumaSport 8 Prism Light Head Electrical Performance Data

Product	Drive Current	DC Voltage	Light head Power (Driver Output Power)
EPH-LS-08-500PR	Up to 1.8 A per channel, Up to 3.4 A per return wire	72 VDC	500 W

Operating Conditions and Clearances

Refer to the following sections for thermal, optical, and mechanical clearance requirements.

Thermal Clearances - Safe Operation

Installer shall verify there are adequate clearances around fixture to allow for proper heat dissipation and fire hazards. The light head produces a significant amount of heat and should not be installed in any confined space. Any combustible materials or structures that could limit the airflow around the light head heatsink must be at least 36in away from the light head (example ceiling). Mounting structures, adjacent fixtures or non-combustible materials can be within this limit.

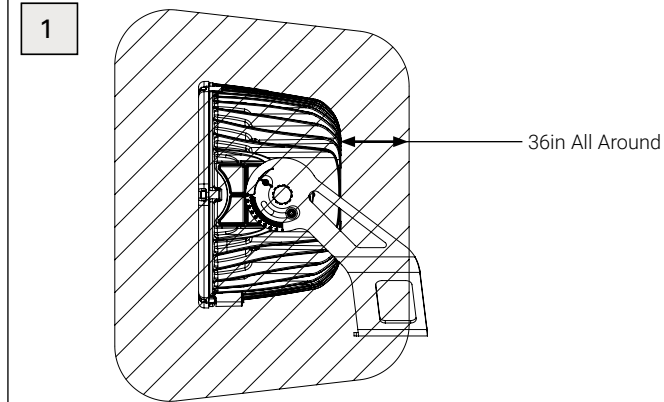

Risk of Fire. Do not install fixture within 915 mm (36 in) of any combustible material.

Optical Clearances – Maximizing Light Levels

Install fixtures according to the location and aiming data exported from photometric models to achieve desired results. However, any objects in the light path between the luminaire and the playing surface will diminish the light levels. Some examples of obstructions are building structural members, electrical panels, HVAC ductwork, banners, and scoreboards.

Before installing your lighting project, verify that there is a clear line of sight from every luminaire location to the designed aiming area, which includes not only the aiming point coordinate but also the area surrounding that aiming point. The illumination area for each fixture varies with mounting height and beam angle, but the purpose is to identify all obstructions and analyze how each will impact the light output on the playing surface, and then take corrective action as necessary to avoid the obstruction. For example, a structural beam directly in front of a luminaire will block the light from reaching the target, so in that case, the luminaire should be shifted to avoid the beam.

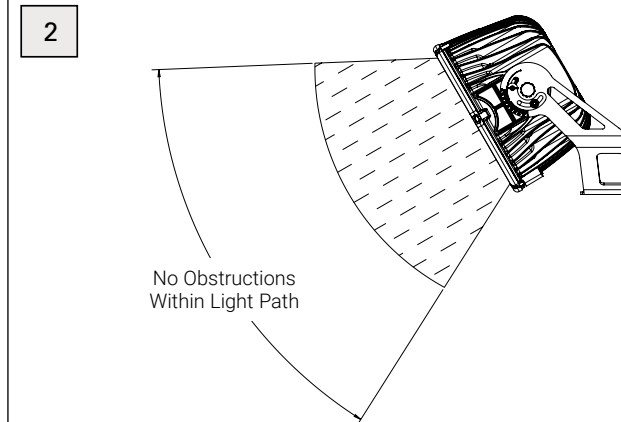

Mechanical Clearances - Avoiding Obstructions

In general, fixtures can be moved up to 5ft from the designed location without affecting photometric results as long as they are aimed at the designed aiming coordinates. For significant obstructions, photometric models should be revised with accurate obstruction dimensions to provide new fixture location and aiming data that avoids the obstruction. If options are limited, consider swapping that fixture aiming with a nearby fixture of the same type that allows clear line of sight to the aiming points. Consult your photometric designer for assistance with finding solutions to major obstructions for your project.

Proper planning will ensure the best results for your sports lighting project. Once these steps are completed, then proceed to the luminaire installation.

Light Head: TY = Top Yoke Dimensional Details

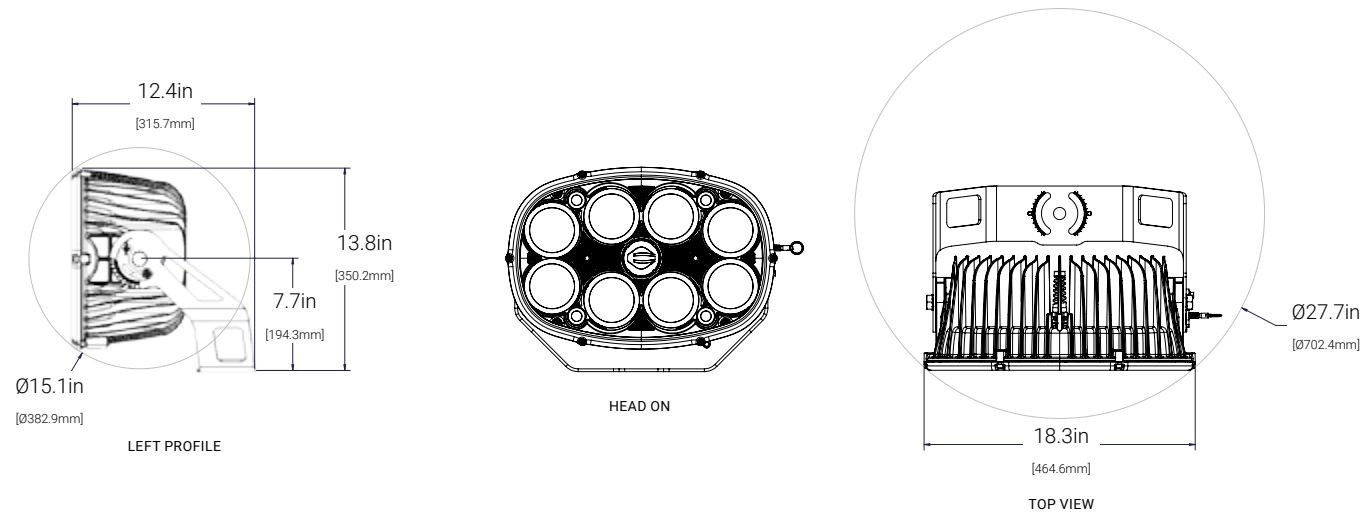

Light Head with Cut-off Visor: TY = Top Yoke Dimensional Details

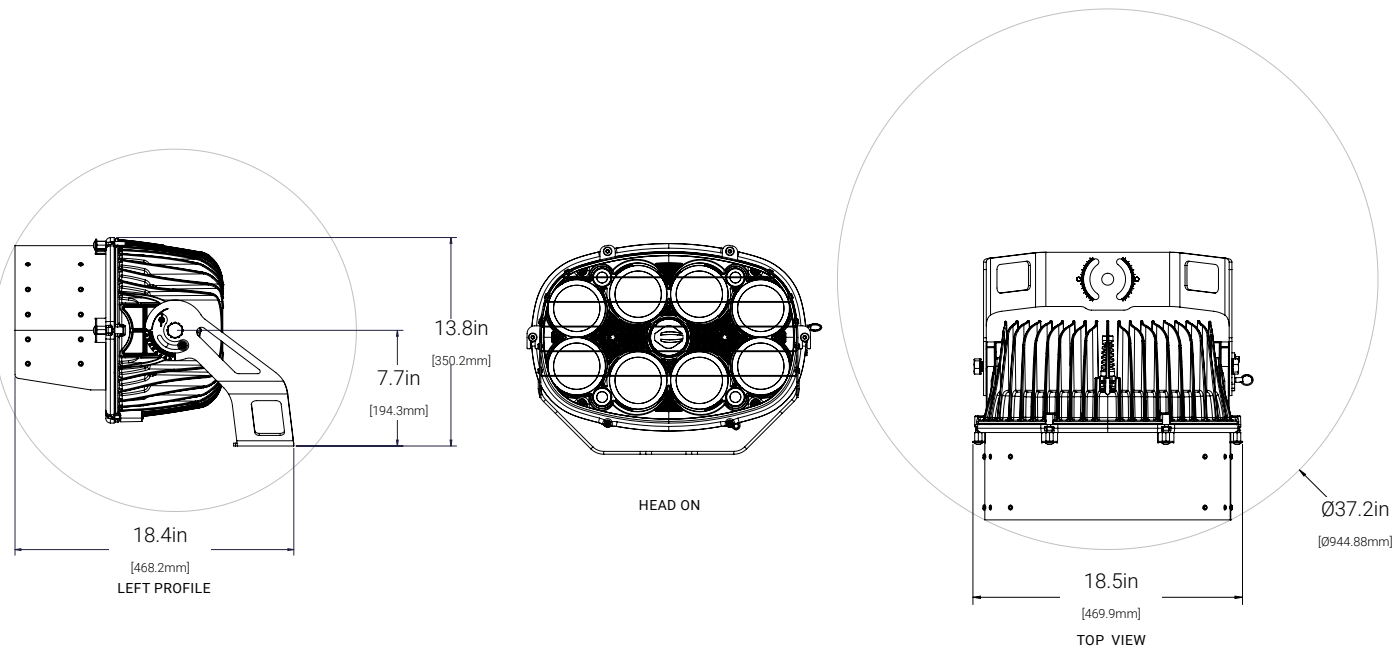

Light Head: QC = Quick Mount Dimensional Details

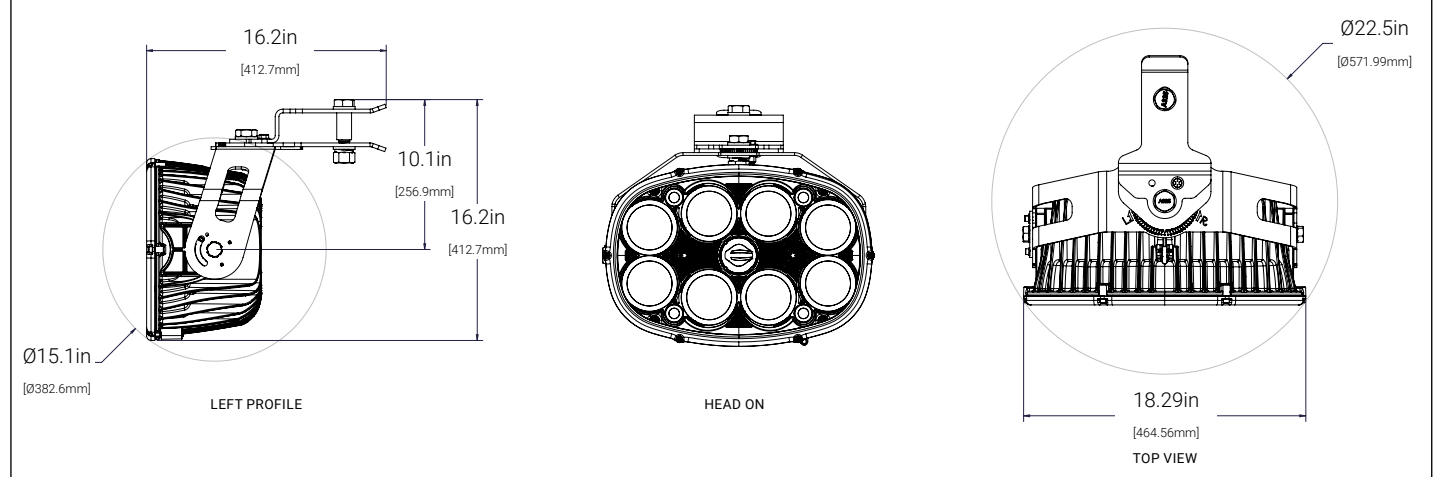

Light Head with Cut-off Visor: QC = Quick Mount Dimensional Details

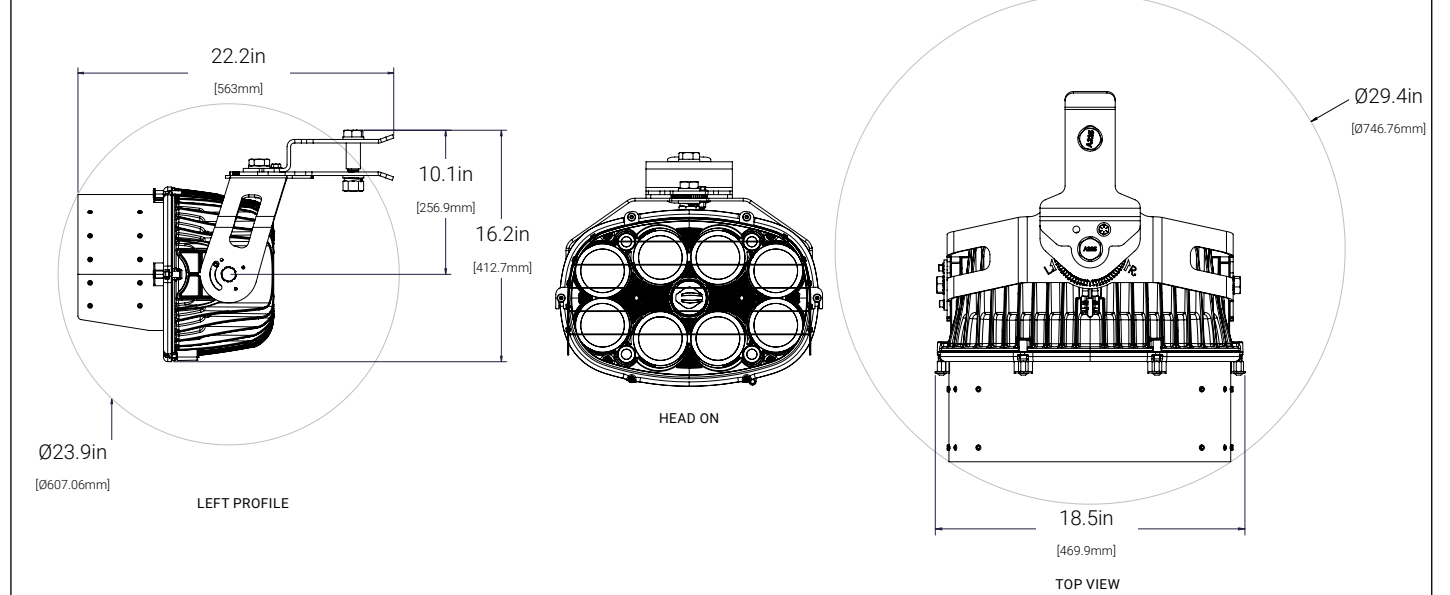



INSTALLATION INSTRUCTIONS

Step 1 – Prepare the luminaire

Always turn all fixture power sources OFF before performing any work.



WARNING

Failure to disconnect all power sources may lead to damage, injury, or death.

Preparing the existing structure



Potential interference between the crossarm or platforms and the light head shall be evaluated prior to installation. Cooper lighting is not responsible for existing structures. Evaluation based on weight and EPA is required for existing structures, see contract terms for details.



Electrical configuration shall be evaluated for compatibility with the Ephesus remote system. If existing wires are re-used, wiring and electrical connections shall be inspected for degradation, abrasion or any other defects that could lead to failure. Any wires or cabling exposed to the weather (external to the crossarm, poles or conduit) shall always be replaced. Cooper lighting is not responsible for the existing wiring.

Electrical Wiring

The existing structure shall have a dedicated ground path between all light heads and the Ephesus PAC Box. The remote configuration requires two adequately rated direct wire runs between each light head and PAC Box. The wiring between light head and PAC Box must be 14AWG, 600V, 90C rated and compliant with all local, state and federal electrical regulatory codes. Cable lengths between all light heads and PAC Box must be less than 200ft.

Map the new and existing fixtures

In retrofit applications, the existing fixture will need to be removed. Any associated bracketry to support fixture shall also be removed. Do not discard of any existing equipment during a retrofit until after the full installation of the new Ephesus system is complete. Markings, hardware, and connectors may assist in during the retrofit process. Any information mapping the light head location to the Distribution Box shall be recorded and saved for future use. This is required to link light head location and the remotely located power and control components.

Note: For retrofit applications, Cooper Lighting recommends recording mapping information on in a prominent document and labeling or otherwise marking the existing fixture number on the bracket or mounting structure to facilitate future identification from the working area.

Preparing the light head

Note: All fixtures that have the exact same model number are functionally identical as built from the factory.

Label the Light Head

Label each Light Head with the fixture number as designated in the photometric design document.

Labeling is important because:

- It helps to remove errors if the fixture will be pre-aimed
- is required to track the wiring between the different components of the remote power system.
- Limits improper addressing during the control commissioning process.

Recommended label is a weatherproof adhesive label that has a white background with black lettering at least 1/2in tall. Paint markers or other methods may also be acceptable – verify with owner. Affix label to the light head or mounting bracket in a prominent location.

Marking the crossarm surface (top mount retrofit only)

To pre-aim the fixture orientation, draw a reference line on the mounting surface. Use a paint pen or other marker to draw a line across the center of the mounting hole, parallel and perpendicular with the crossarm or mounting structure. The crossarm should typically but not necessarily be perpendicular to the direction of the field of play. The line should extend at least 3in out from the center of the mounting hole.

11

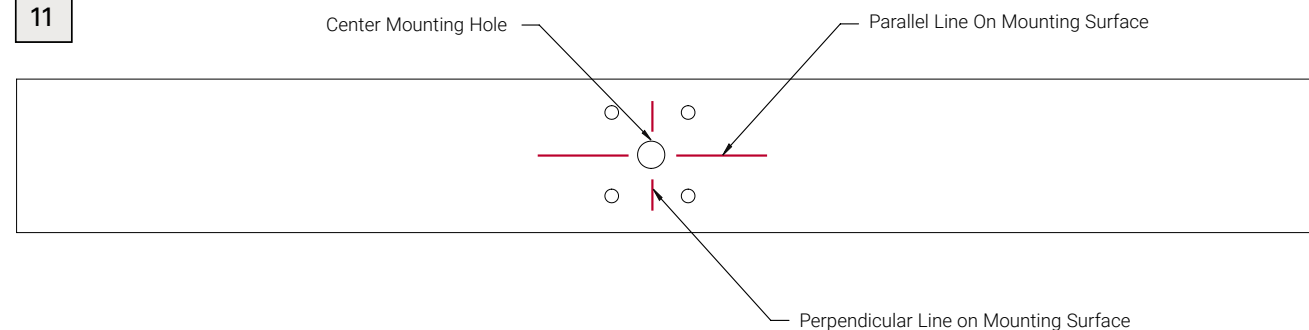

PRE AIMING – TOP MOUNT YOKE

Pre-aiming requires a level mounting surface and knowledge of the cross arm orientation. The Light head with the remote top mount yoke can be pre-aimed using the tilt guide on the left side of yoke and at the orient guide on the base of the yoke. Refer to photometrics or project installation drawings for the orient and tilt angles.

If laser aiming, verify the light head is secure in the yoke and mounting surface but do not fully torque hardware until final aiming is complete.



If the yoke is inverted, to the bottom mount configuration, the light head must remain rightside up with the vents at the bottom. The Laser Aiming Pin feature should always be on the top.

Set pre-aiming tilt angle

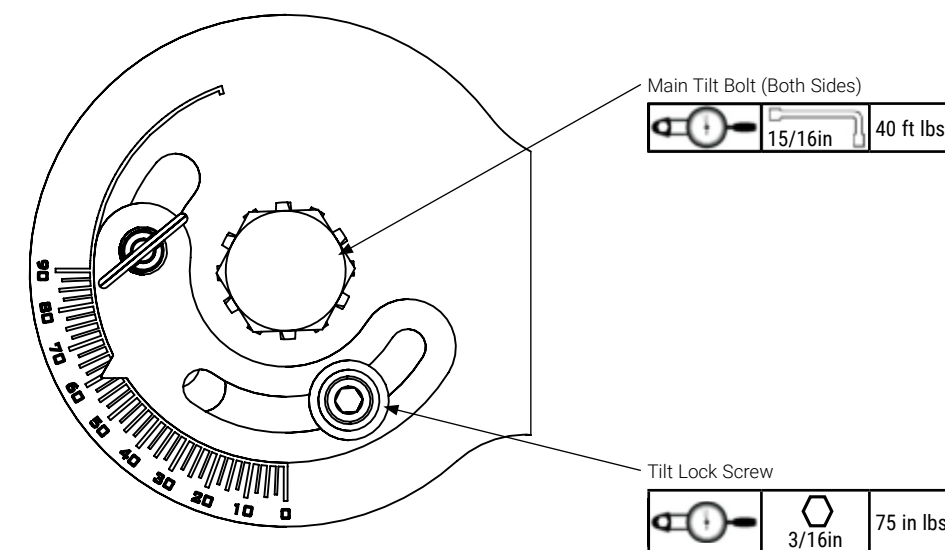

Note: Example shown at 70° tilt

Loosen the two main tilt bolts and tilt lock screw slightly to allow the light head and aiming plate to rotate inside the yoke. Verify the spring plunger is engaged into the light head. If not, rotate it into the locking position.

Do NOT over-loosen or remove tilt lock screw. Prevent access to area under fixture until the final torquing is complete.

Rotate the labeled aiming plate until the arrow is over the desired tilt angle. Hold the aiming plate in place and tighten the tilt lock screw and then the two main tilt bolts to the torques specified in the corresponding illustration

Mounting the light head

Mounting center bolt shall be 3/4zin diameter corrosion resistant steel (HDG, hot dipped galvanized high-strength steel is recommended) with nut and locking washers. A secondary 3/8in diameter corrosion resistant steel bolt with nut, flat and locking washers shall be used to lock the orient. The length of bolts is determined in the field depending upon thickness of mounting structure. Size bolts appropriately to allow secure fastening of the luminaire to the mounting structure. Tighten hardware so that fixture is secure but do not fully torque hardware until aiming is complete.

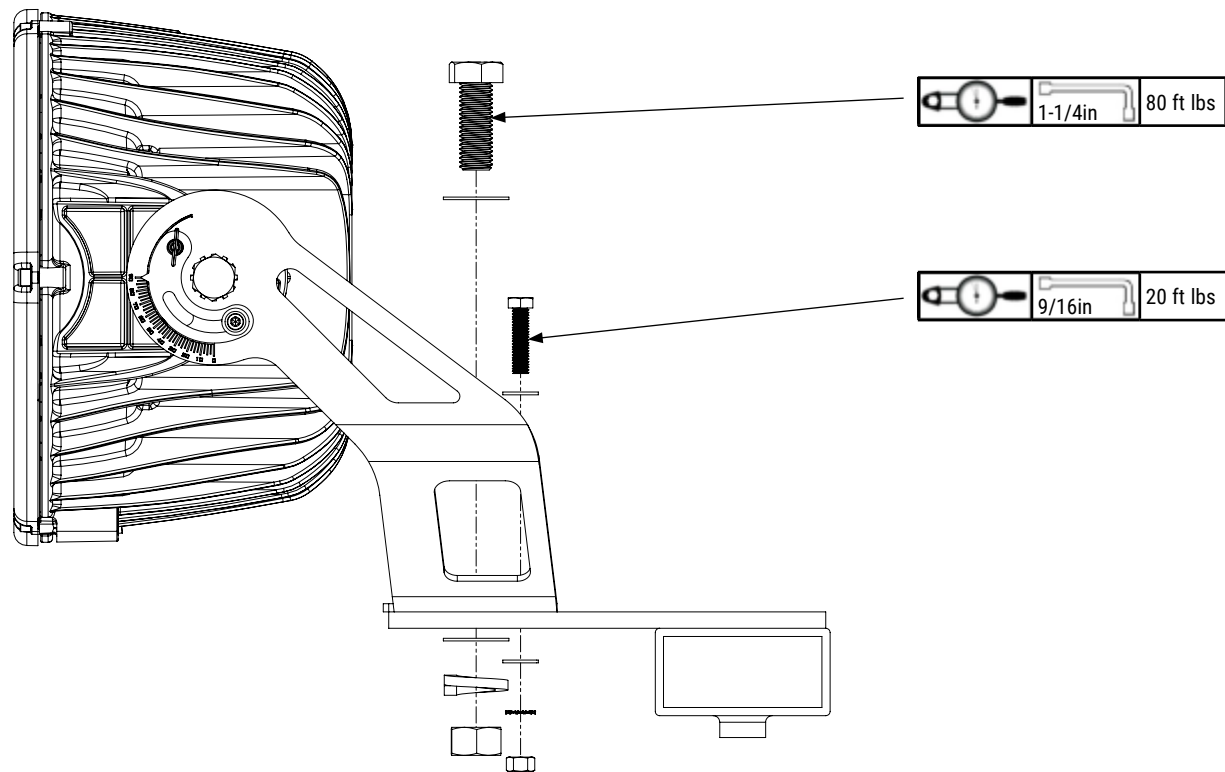

Set pre-aiming orientation angle

(Pre-aim Orientation 0-55°)

To pre-aim the light head orientation, rotate the light head about the mounting bolt until the parallel reference line that was marked on the mounting structure is aligned with the correct angle shown in white on the yoke orient label. Tighten the main orient bolt and orient lock screw per the spec in the corresponding illustration



Prevent access to area under fixture until the final torquing is complete.

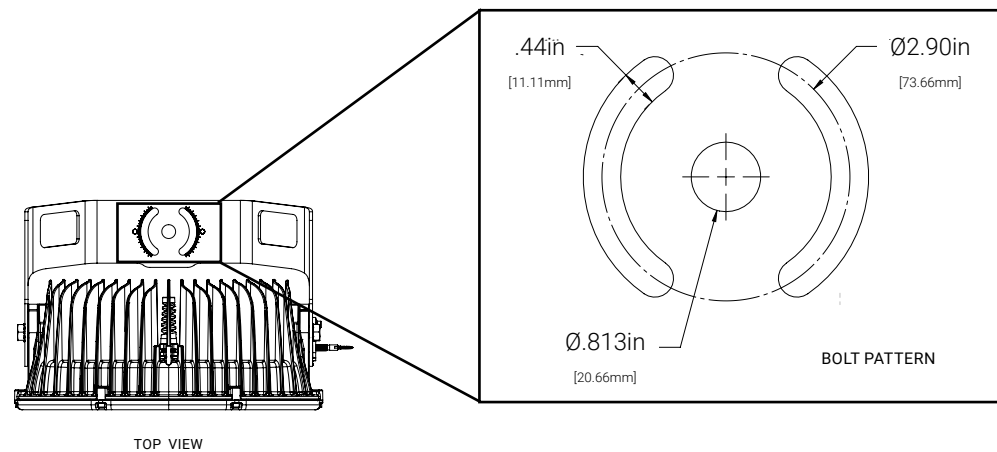

Orient the light head (Pre-aim Orientation 0-55°)

To pre-aim the fixture orientation, rotate the light head about the mounting bolt until the parallel reference line that was marked on the mounting structure is aligned with the correct angle shown in white on the orient label in the bottom of the light head.

13a 0-55° Left

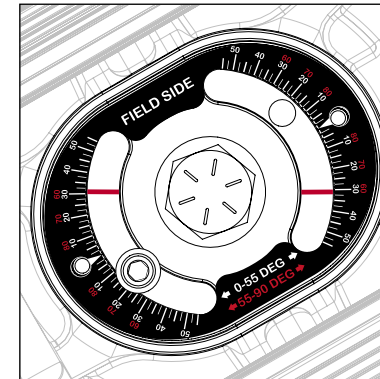

13b 90° Straight to Field

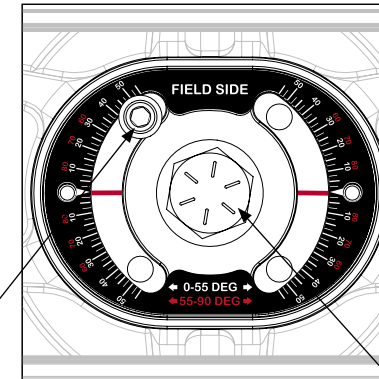

13c 0-55° Right

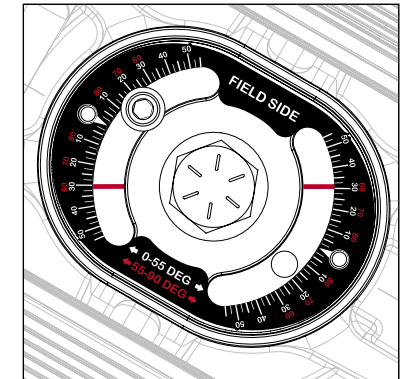

Orient Lock Bolt

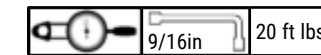

Main Mounting Bolt

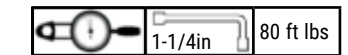

Orient the light head (Pre-aim Orientation 55-90°)

To pre-aim the fixture orientation, rotate the light head about the mounting bolt until the perpendicular reference line that was marked on the mounting structure is aligned with the correct angle shown in red on the orient label in the bottom of the light head.

13a 55-90° Left

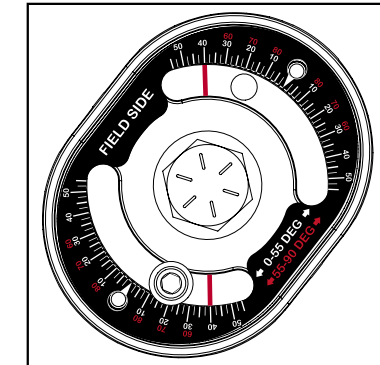

13c 55-90° Right

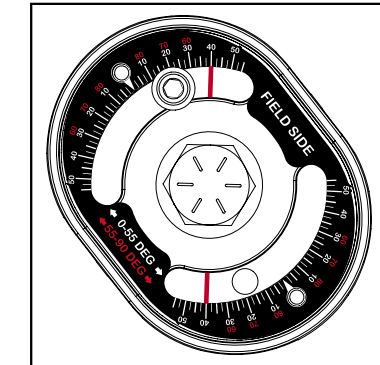

If laser aiming, tighten the mounting hardware so that fixture is secure but do not fully torque hardware until final aiming is complete.

If using the orient gauge, torque the mounting hardware at this step to the values in the table below. If you are laser aiming, torque the hardware to the specification once the fixture is aimed.



PRE AIMING – QUICK CLAMP ASSEMBLY

Pre-aiming requires a level mounting surface and knowledge of the cross arm orientation. The Light head with the quick clamp assembly can be pre-aimed using the tilt guide on the right side of yoke and at the orient guide on the top of the yoke. Refer to photometrics or project installation drawings for the aiming point coordinates.

If laser aiming, verify the light head is secure but do not fully torque tilt and orient hardware until final aiming is complete. The clamp bolt assembly shall be fully torqued prior to laser aiming.



The quick clamp assembly only allows for bottom mounting. The clamp cannot be inverted.



The primary tilt lock screw is kitted with the quick clamp assembly. Do not discard. They are required for quick clamp assembly.

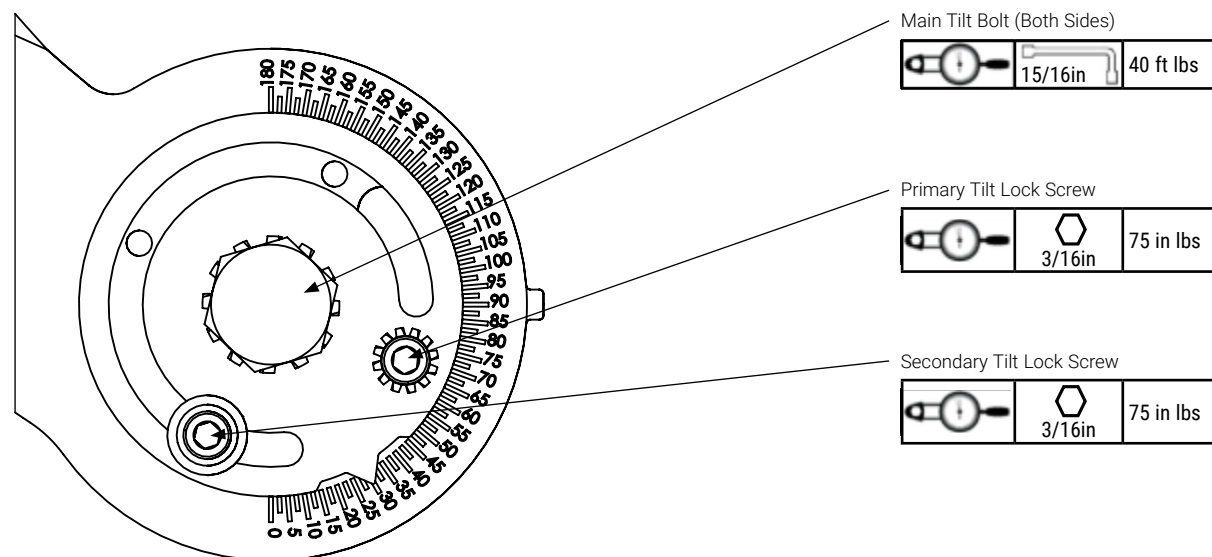

Note: Example shown at 30° tilt.

Loosen the two main tilt bolts to allow the light head to rotate inside the yoke. Loosen the secondary tilt lock screw to allow the aiming plate to rotate. Install the 1/4in-20 primary tilt lock and tooth lock washer that was kitted separately into the light head. The aiming plate and light head may need to be rotated to get the threaded hole in the light head to align.

Do NOT over-loosen or remove the tilt lock screw. Prevent access to area under fixture until the final torquing is complete.

Rotate the labeled aiming plate until the arrow is over the desired tilt angle. Hold the aiming plate in place and tighten the primary and secondary tilt lock screws and then the two main tilt bolts to the torques specified in the corresponding illustration

Orient the light head (front side mounting)

To pre-aim the light head orientation, rotate the clamp about the light head until the pointer is aligned with the correct orient angle shown with a "F" subscript. The indicator on the clamp should point forward in the direction the light will be shining. Tighten the main orient bolt and orient lock screw per the spec in the corresponding illustration

13a 90-180° Left

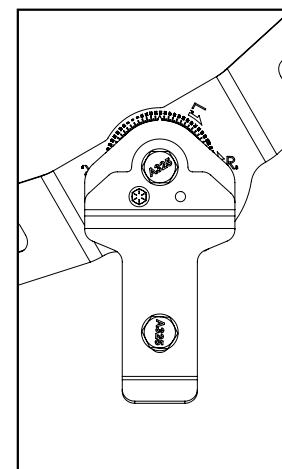

13b 90° Straight to Field

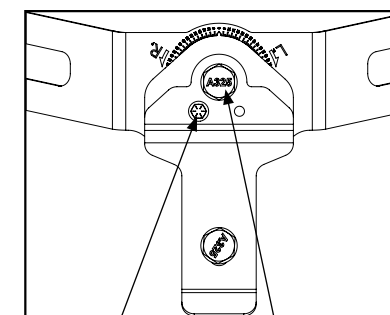

13c 0-90° Right

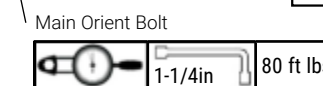
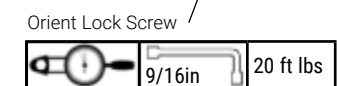
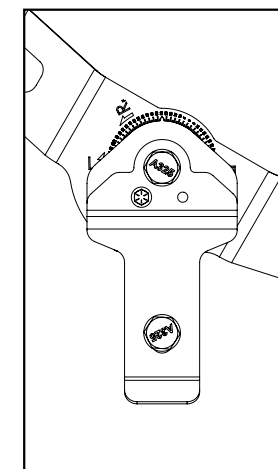

Orient the light head (back side mounting)

To pre-aim the light head orientation, rotate the clamp about the light head until the pointer is aligned with the correct orient angle shown with a "B" subscript. The indicator on the clamp should point backwards in the opposite direction the light will be shining. Tighten the main orient bolt and orient lock screw per the spec in the corresponding illustration (see change: graphic with balloon call-outs).

13a 90-180° Left

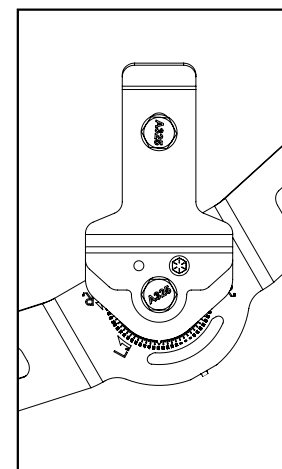

13b 90° Straight to Field

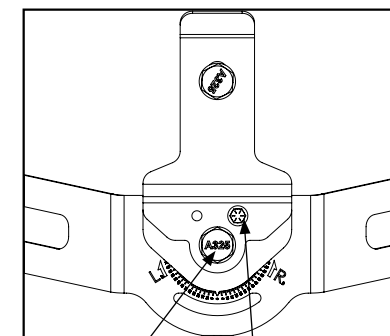

13c 0-90° Right

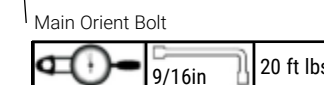
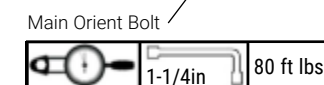
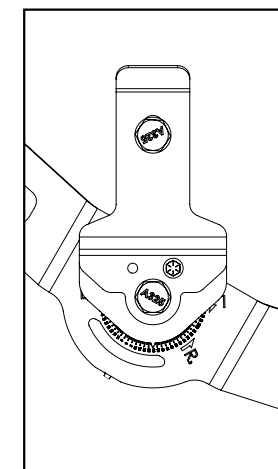

Mounting the Light Head

Remove the clamp bolt assembly. Slide the clamp over the crossarm until the front of the clamp is flush to the crossarm. Insert the main bolt through the two holes in the clamp, spacer sleeve and clamp hardware. Tighten the clamp hardware assembly per the spec in the corresponding illustration.

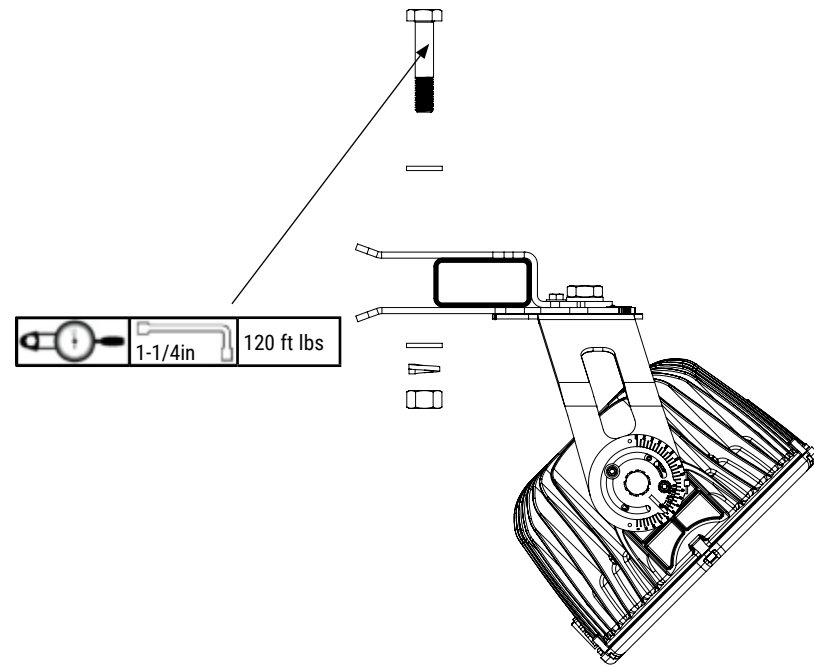

Laser Aiming

Ephesus light heads are capable of pre-aiming or laser aiming. Laser aiming may be the preferred method when: the crossarm orientation is unknown or irregular, lighting specifications are very restrictive typical of higher classes of play, or fixtures with narrow beams are located extremely far from the surface typical of larger venues. If fixture pre-aiming using the tilt and orient gauges is satisfactory and laser aiming is not required, you can skip this step.

Slightly loosen the fixture tilt and orient hardware just enough to allow the light head to rotate and tilt. Do NOT over-loosen or remove set screw.

Insert the aiming mount onto the fixture aiming pin until it is fully seated tight against the fixture. Turn on the laser and aim the fixture by targeting the laser dot at the aiming point.

21a

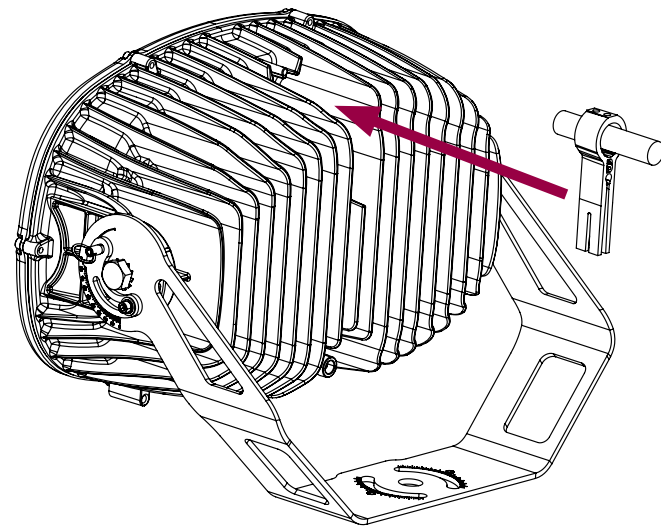

21b

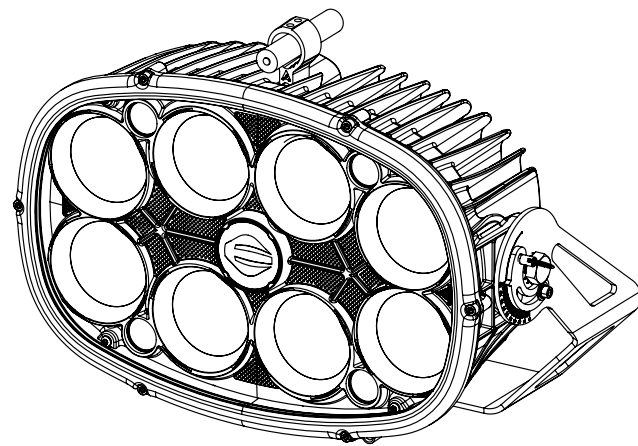

Note: Laser aiming may be difficult outdoors on bright sunny days. A diffuse reflective tarp located around the aiming point can facilitate aiming. The use of a daytime scope aimer is also available.

Note: Turn off laser while not in use to conserve battery. Have spare battery charged to facilitate the aiming process.



Make electrical connections

Cordset

For projects that include new poles or crossarms, light heads are factory wired with a cordset. To make the electrical connection, install the plug on the light head into the mating receptacle on the crossarm. Tighten the threaded nut to fully secure the connector.

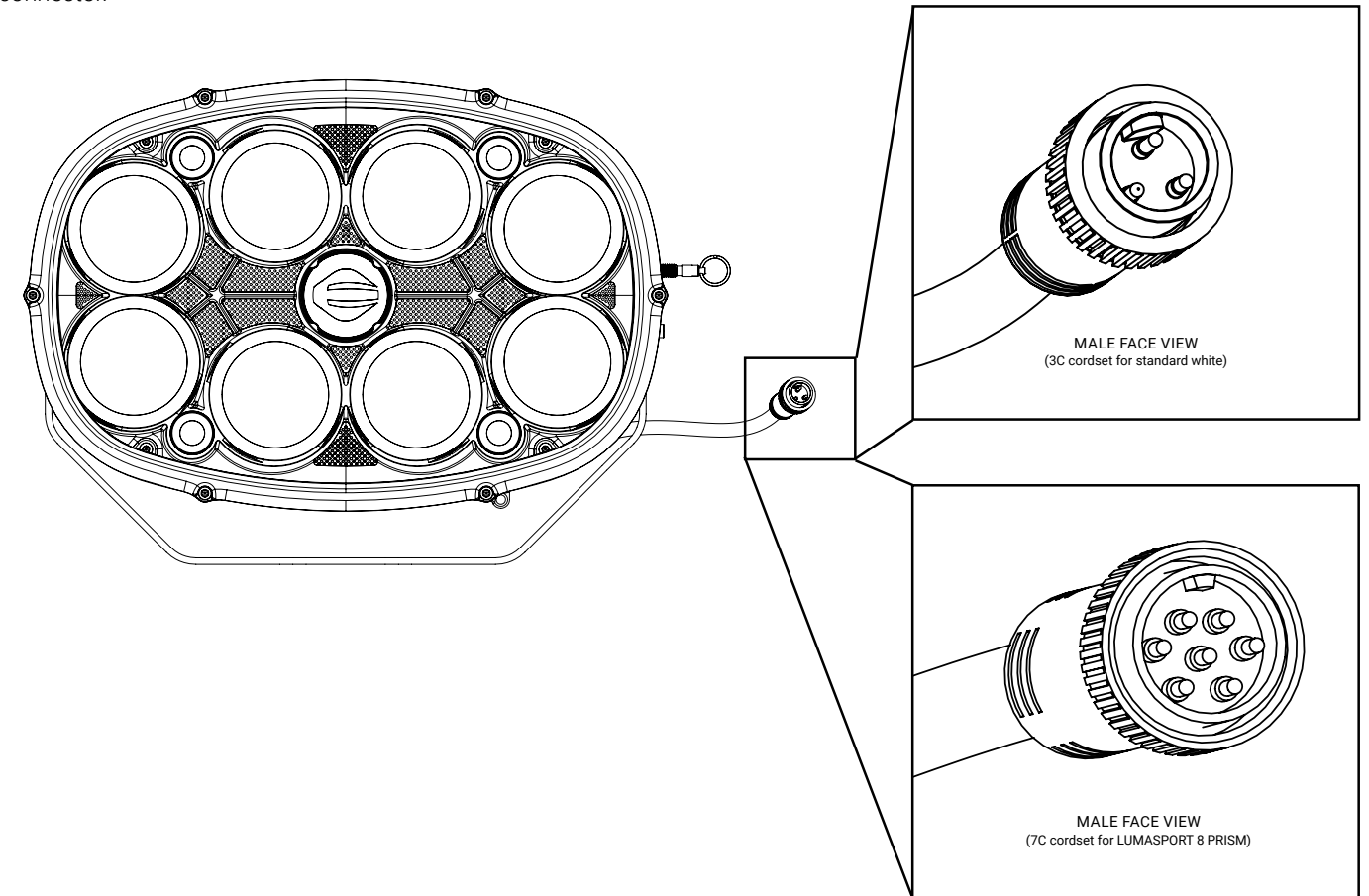

Retrofit Adapter Cable

The Retrofit Adapter Cable comes with an electrical interface plate that bolts directly to some crossarms that are wired for remote ballasts.



Always verify the crossarm is electrically grounded when using the retrofit adapter cable



The use of this connection method requires knowledge of the wiring between the light head and Distribution Box. DC + and DC - on the light head must be appropriately matched to the DC + and DC - on the PAC Box.

Drop cable DC wiring will need to be identified and designation aligned at light head and distribution box

CABLE TYPE	LIGHT HEAD		DISTRIBUTION BOX
	DESIGNATION	WIRE COLOR	SPLICE CONNECTOR LANDING
RETROFIT ADAPTER CABLE	DC +	BLACK	GRAY SPLICE CONNECTOR
	DC -	WHITE	WHITE TWIN SPLICE CONNECTOR
	GROUND	GREEN	POLE GROUND

To make the electrical connection, use moisture resistant crimp on butt splice connectors to attach the wire ends on the light head to the wires in the crossarm. Trim the wire end to the specified length. Follow the manufacturer's instructions for installation of the connector.

Note: The moisture resistant splice connector may have a heat shrink tube sleeve which requires a heat source to properly seal. The wire end may also need to be trimmed to 1/4in from the insulation for proper fitment.

Secure the retrofit adapter cable to the crossarm using 3/8 nuts.



Verify no wires are pinched during the mechanical assembly of the electrical interface plate.

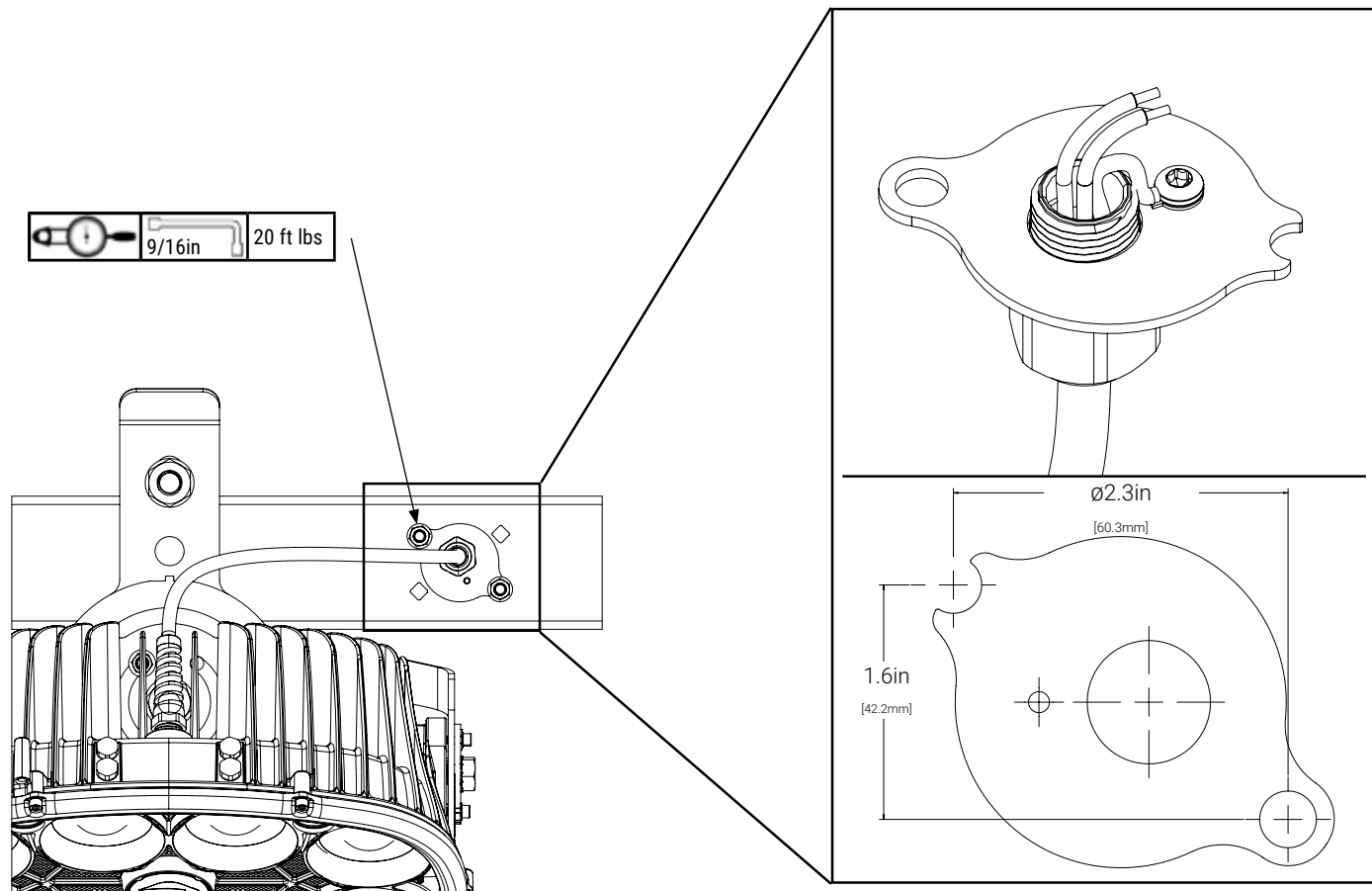

Light Head Cable (DC)

An appropriately rated electrical enclosure or connection method is required when the light head has a C10 cable. Refer to the wire designation for proper wiring.

LIGHT HEAD		
CABLE TYPE	DESIGNATION	WIRE COLOR
C10	DC +	BLACK
	DC -	WHITE
	GROUND	GREEN

To make the electrical connection, use waterproof crimp on butt splice connectors to attach the wire ends on the light head to the wires in the mating DC wires. Trim the wire end to the specified length. Follow the manufacturer's instructions for installation of the connector.

Note: The moisture resistant splice connector may have a heat shrink tube sleeve which requires a heat source to properly seal. The wire end may also need to be trimmed to 1/4" from the insulation for proper fitment.

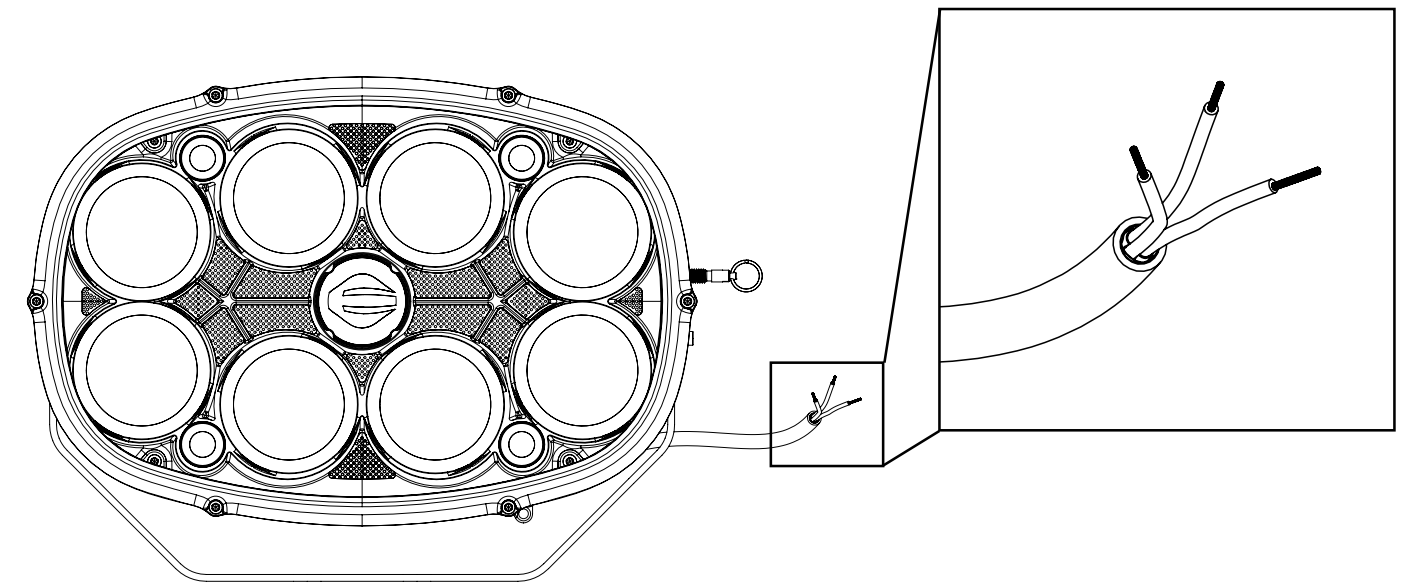

System Performance

See PAC and Distribution box instructions to complete system wiring.

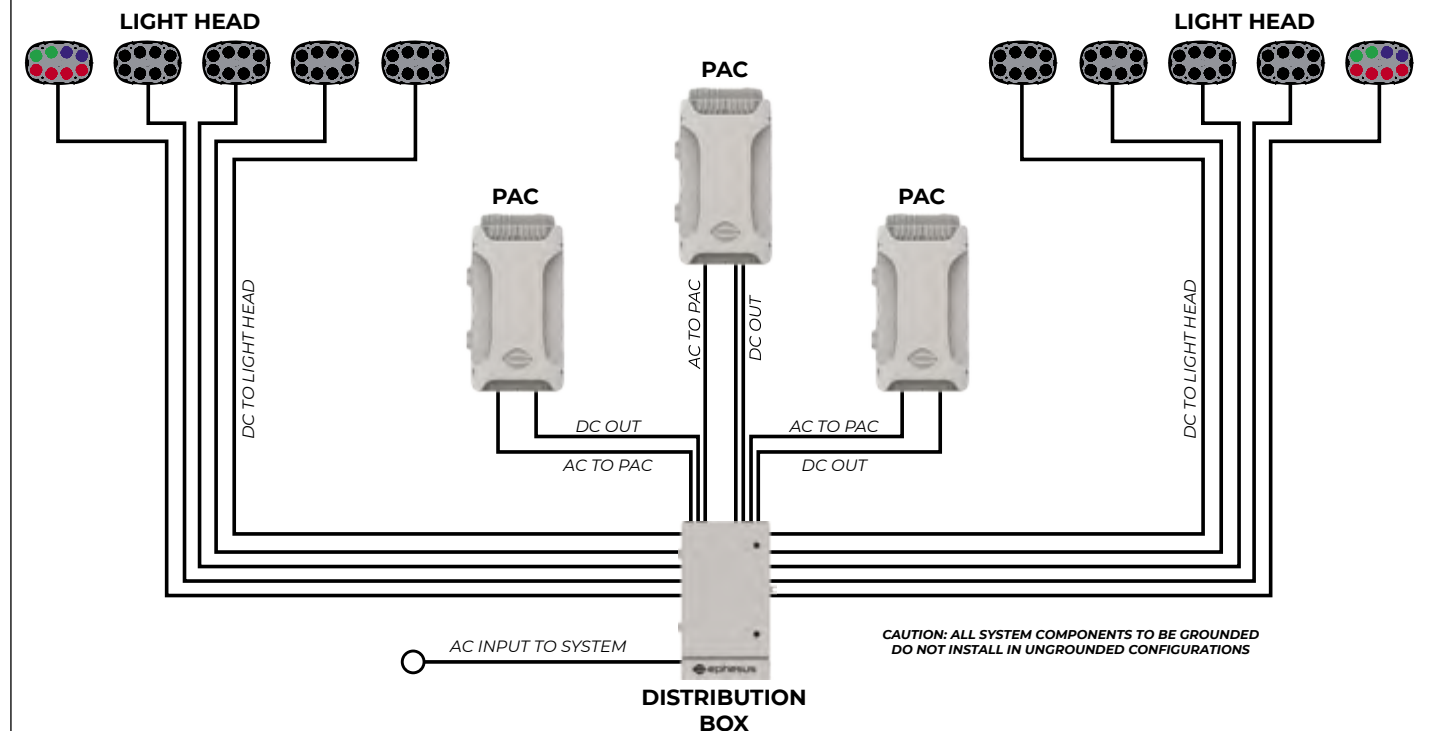

The light head shall never be plugged directly into AC power. It will damage the light head and void the warranty.



Mounting Accessories

Diving Board Kit

Diving Board is intended to only to mount to 2in x 4in steel cross arms. Designed to be used with the LUMADAPT 8, LUMASPORT 8, LUMASPORT 16, and LUMASPORT 8 PRISM light heads only. Do not use in unapproved light heads or mounting applications.

WARNING



Diving Board may ONLY be installed in the following physical orientations. Failure to install the Diving Board Kit in approved orientation or location may result in damage, injury, or death. (Reference diagram DB4a and DB4b on page 20)



Prevent access to area under fixture until the final torquing is complete.

DB1 Diving Board Kit

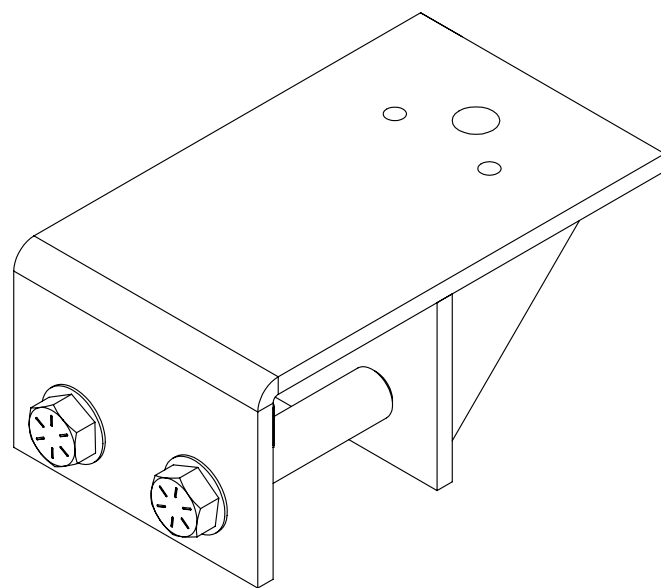

DB2 Diving Board Kit Parts Diagram

Item #	Description	Quantity
1	Diving Board Bracket	1
2	Bolt Sleeve	2
3	3/4in-10 X 6in Structural Hex Bolt, Hot Dip Galvanized	2
4	3/4in Steel Flat Washer, Hot Dip Galvanized	2
5	3/4in Ext Tooth Washer, Steel, Magni-565 Grey Polycoat	2
6	3/4in-10 Structural Steel Hex Nut, Hot Dip Galvanized	2
7	Stainless Shim	1

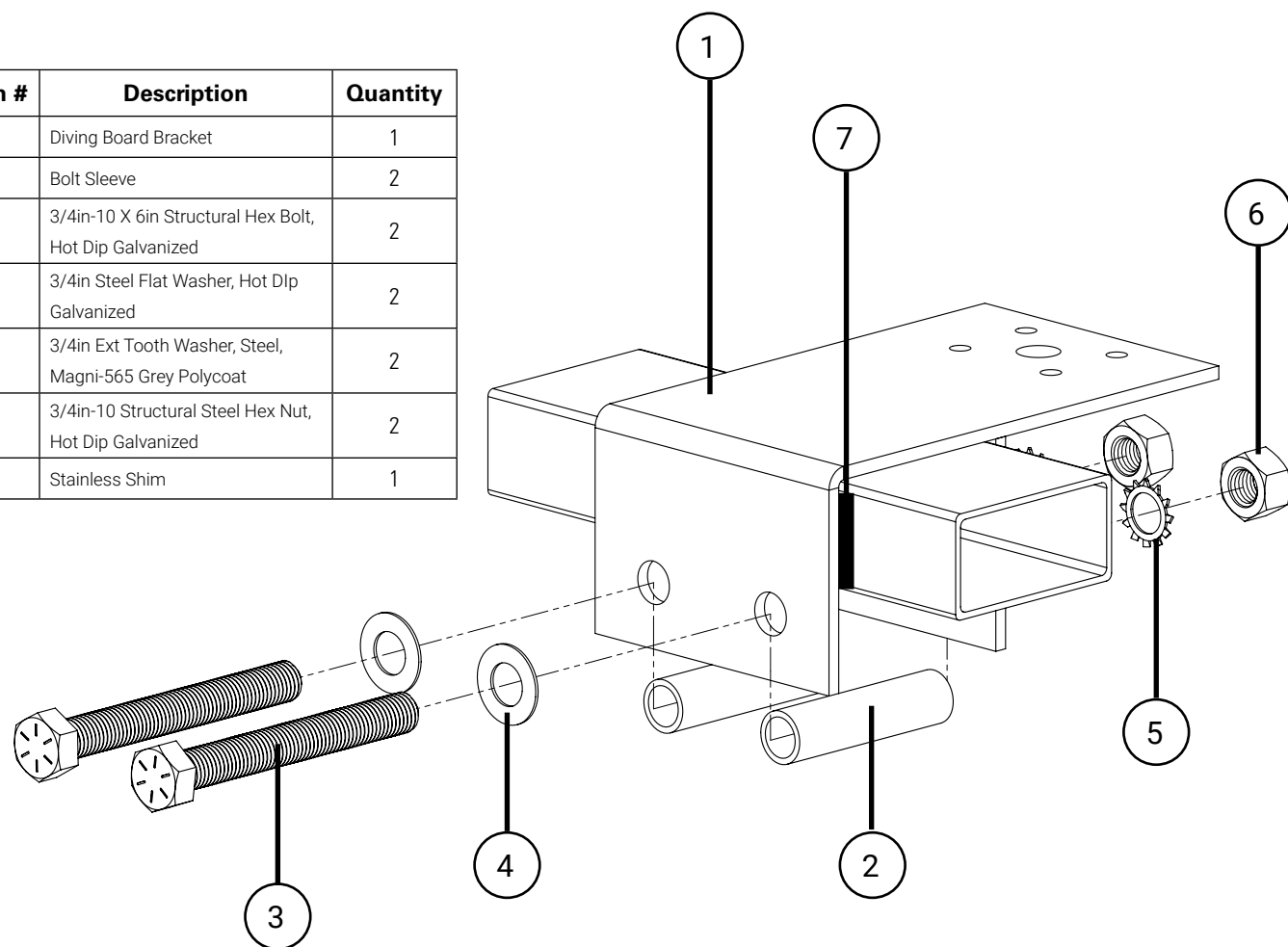

Diving Board Kit (DVGBRD) Hardware

Hardware Description	Use / Location	Tool	After Aiming Torque
3/4in-10 X 6in Structural Hex Bolt, Hot Dip Galvanized	Diving Board is intended to only to mount to 2in x 4in steel cross arms.	<ul style="list-style-type: none"> 1 1/8in Socket & Ratchet 9/16in Socket & Ratchet Adjustable Crescent Wrench Adjustable Torque Wrench 	120ft-lb.

Additional (HRDM34) Mounting Fastener Hardware Kits

Hardware Description	Use / Location	Tools	After Aiming Torque
HRDM34-025	Additional mounting fastener hardware kit needed to attach a fixture to the DVGBRD = Diving Board	<ul style="list-style-type: none"> 1 1/8in Socket & Ratchet 9/16in Socket & Ratchet Adjustable Crescent Wrench Adjustable Torque Wrench 	80ft-lb
HRDM34-075	.50-.75in clamping thickness, flat surfaces drilled for 3/4in hardware		
HRDM34-200	2.00in clamping thickness, use for 2in x 4in Cross arms that are drilled for 3/4in hardware		



Steps to Install

- The Diving Board is mounted on top of the cross arm with bolts and sleeves mounted underneath to clamp the bracket to the crossarm and secure it. (Refer to the Diving Board Parts Diagram) Only mount it as shown
- Hold Diving Board Bracket (item 1) on top of cross arm.
- Optional: Place provided shim between side of bracket and cross arm if there is excessive clearance
- Insert both Clamping Hex Bolts through Washer, Bracket, Bolt Sleeve, other side of Bracket, Lock Washer, and Hex Nut.
- Torque 3/4in-10 X 6in Structural Hex Bolts: 120ft-lb.
- Hold Fixture on top surface
- Use hardware kit HRDM34-025 for mounting fixture to bracket. Insert 3/4in Fixture mounting bolt through Flat washer, fixture, and primary mounting hole on Diving Board, Flat Washer, Lock Washer, and Hex Nut
- Use hardware kit HRDM34-025 for mounting fixture to bracket. Insert 3/8in secondary mounting bolt through Flat washer, fixture, and any secondary mounting hole on Diving Board, Flat Washer, Lock Washer, and Hex Nut
- Torque fixture bolts:
 - Primary fixture 3/4in bolt torque: 80ft-lb.
 - Secondary fixture 3/8in bolt torque: 20ft-lb.

DB3 Diving Board Kit (DVGBRD) with Additional (HRDM34) Mounting Fastener Hardware Kit

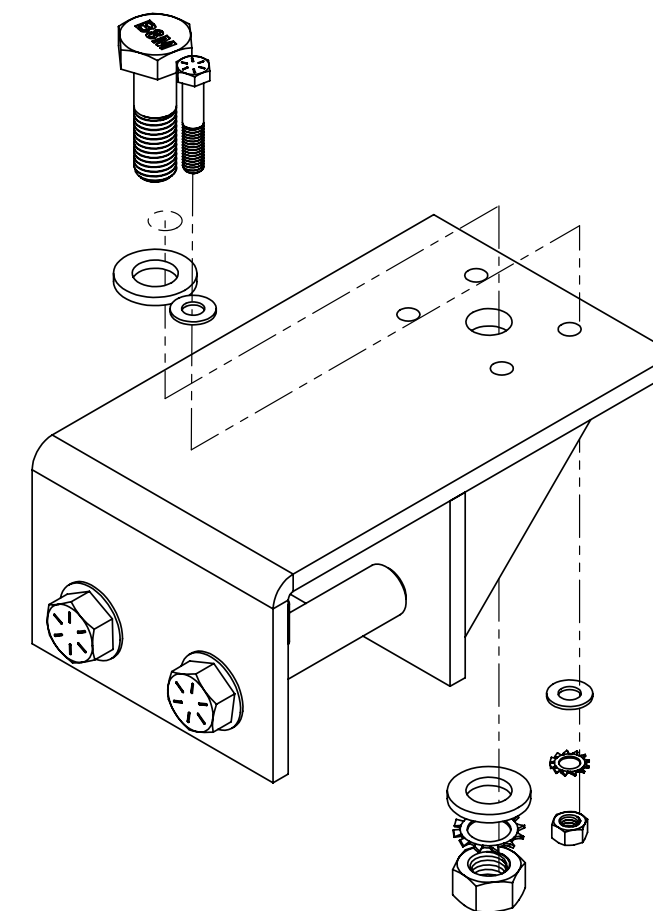

DB4a **Correct Installation**

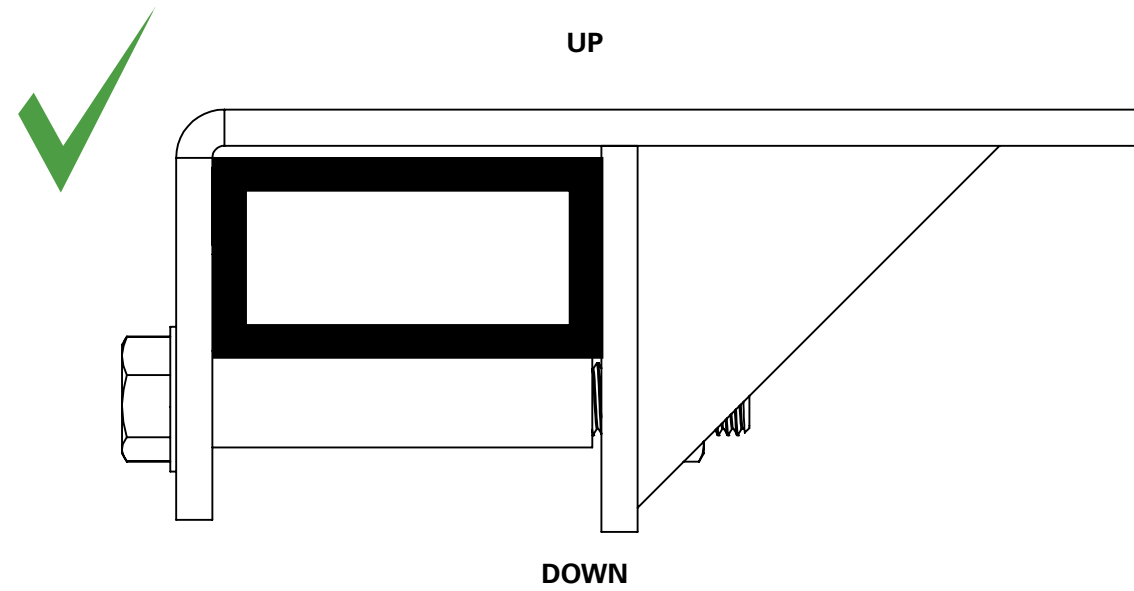

DB4b **Incorrect Installation**

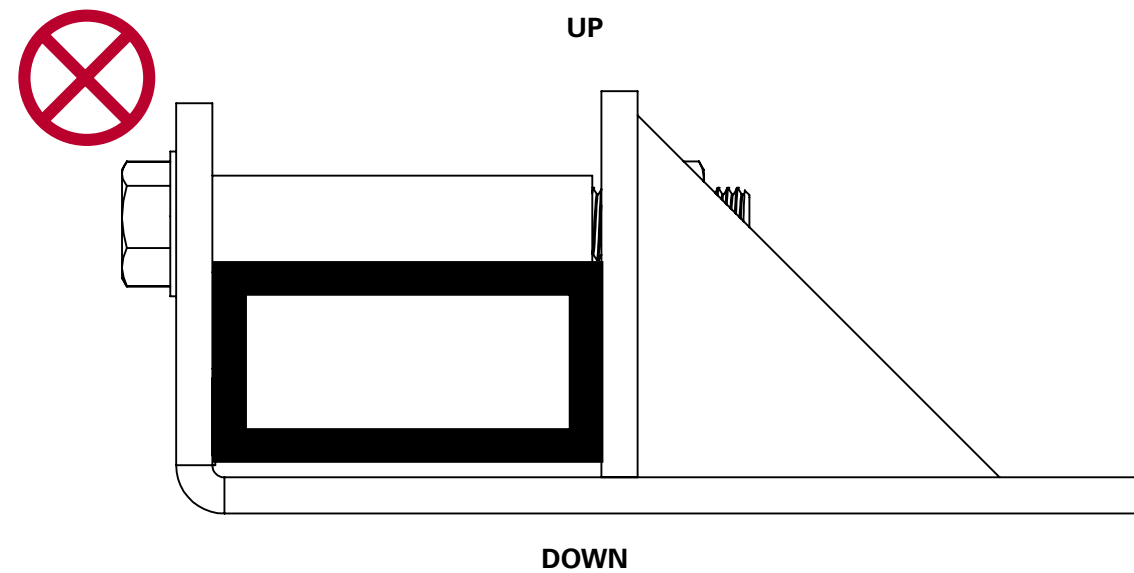



 **Mounting Accessories**

Extension Plate Kit (EXTPLT)

Extension Plate Kit to mount to structures .25in, .5in, or 2.00in thick. Designed to be used with the LUMADAPT 8, LUMASPORT 8, and LUMASPORT 8 PRISM light heads only.

WARNING

 Extension Plate may ONLY be installed in the following physical orientations. Failure to install the Extension Plate Kit in approved orientation or location may result in damage, injury, or death.

 Prevent access to area under fixture until the final torquing is complete.

EP1

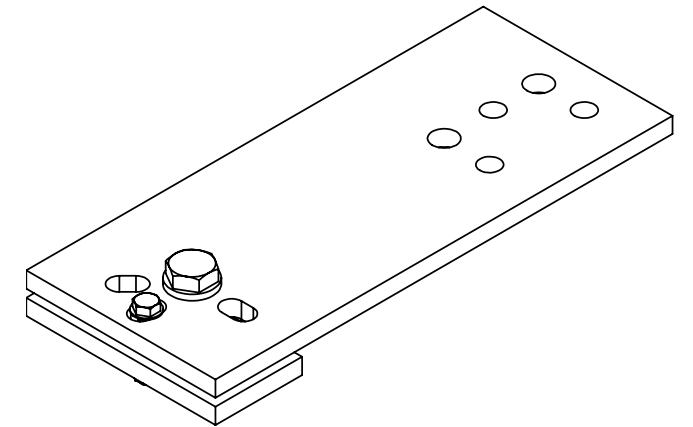

Extension Plate Kit Parts Diagram

Item #	Description	Quantity
1	Extension Plate	1
2	Washer Plate	1
3	5/8in Hex Bolt	1
4	5/8in Washer	2
5	5/8in-11 Hex Nut	1
6	5/8in Split Washer	1
7	3/8in Washer	2
8	3/8in Hex Bolt	1
9	3/8in Split Washer	1
10	3/8in-16 Hex Nut	1

EP2

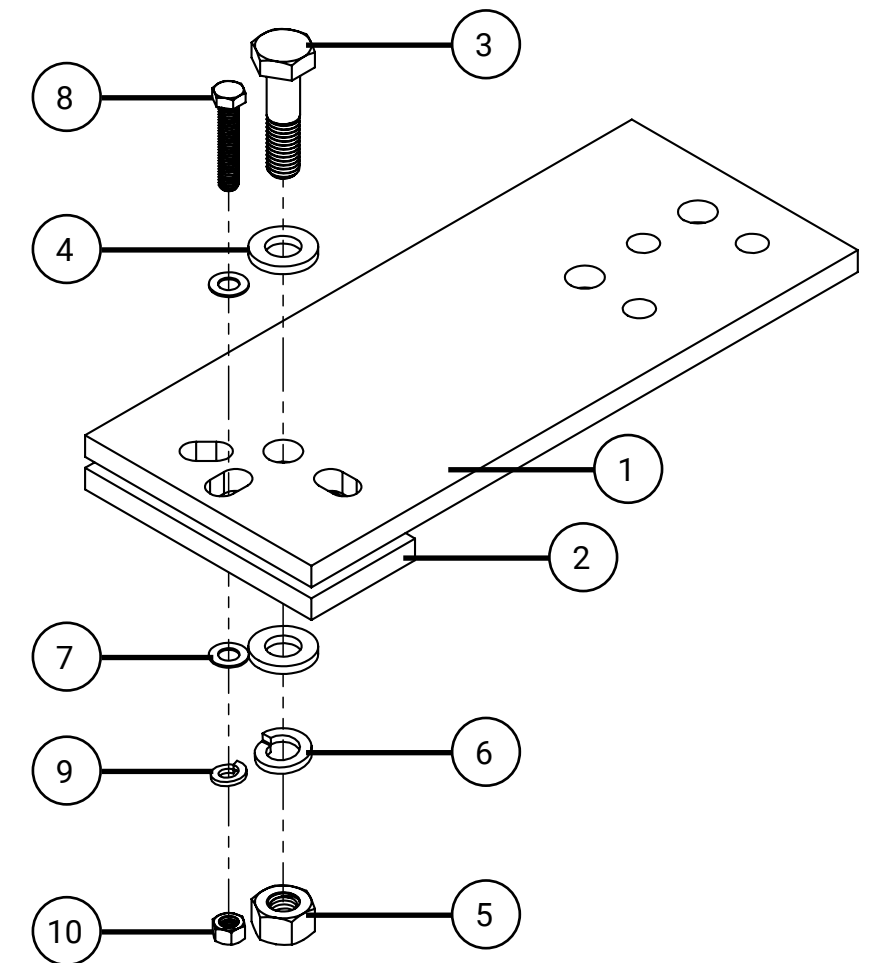

Extension Plate Kit (EXTPLT) Hardware

Hardware Description	Use / Location	Tools	After Aiming Torque
EPH-EXTPLT-025	Extension Plate Kit 5/8in-11 primary and 3/8in-16 secondary fastening hardware to mount to structures .25in thick. Designed to be used with the LUMADAPT 8, LUMASPORT 8, and LUMASPORT 8 PRISM luminaires only.	<ul style="list-style-type: none"> 15/16in Socket & Ratchet 9/16in Socket & Ratchet Adjustable Crescent Wrench Adjustable Torque Wrench 	Primary 80ft-lb Secondary 20ft-lb
EPH-EXTPLT-050	Extension Plate Kit 5/8in-11 primary and 3/8in-16 secondary fastening hardware to mount to structures .5in thick. Designed to be used with the LUMADAPT 8, LUMASPORT 8, and LUMASPORT 8 PRISM luminaires only.		
EPH-EXTPLT-200	Extension Plate Kit 5/8in-11 primary and 3/8in-16 secondary fastening hardware to mount to structures 2.00in thick. Designed to be used with the LUMADAPT 8, LUMASPORT 8, and LUMASPORT 8 PRISM luminaires only.		

Additional (HRDM58) Mounting Fastener Hardware Kits

Hardware Description	Use / Location	Tools	After Aiming Torque
HRDM58-050	.375-.500in clamping thickness, Use for Extension Plate (EXTPLT) or other flat surfaces drilled for 5/8in hardware	<ul style="list-style-type: none"> 15/16in Socket & Ratchet 9/16in Socket & Ratchet Adjustable Crescent Wrench Adjustable Torque Wrench 	Primary 80ft-lb Secondary 20ft-lb
HRDM58-200	2.0in clamping thickness, Use for Extension Plate (EXTPLT) or other flat surfaces drilled for 5/8in hardware		

Extension Plate Kit Mounting Diagram

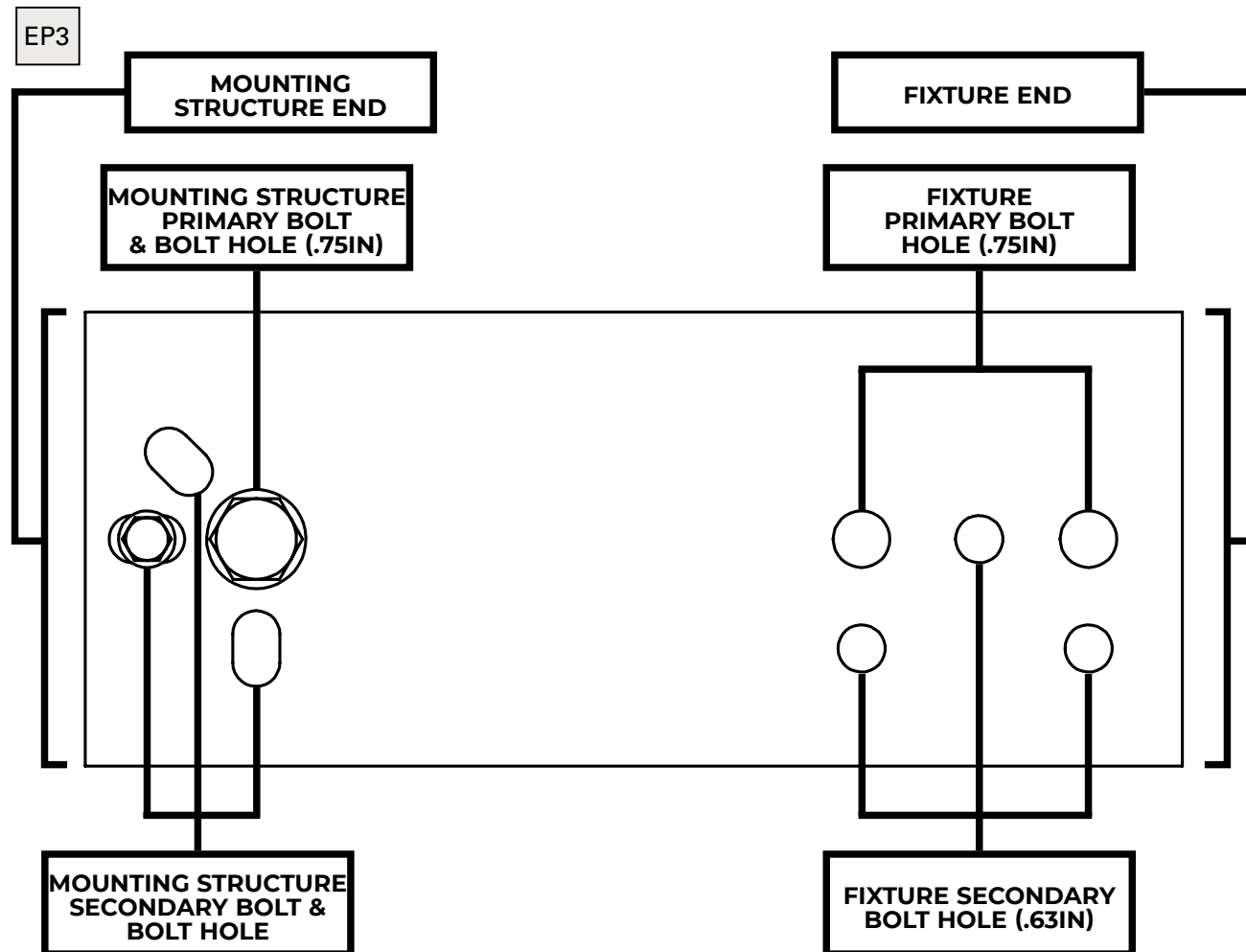

Steps to Install

- Test fit the extension plate on a mounting structure using the method described below to verify no modifications to the structure are required. If additional holes or other structural changes are required, these must be approved by in a qualified structural review.
- Hold extension plate on top of mounting structure and washer plate below mounting structure so that primary and secondary bolt holes align through the mounting structure.
- Install primary bolt, washers, and nut through primary mounting structure holes as shown to secure extension plate and washer plate to structure and tighten securely.
- Install secondary bolt through one of the three secondary mounting structure holes and tighten securely.
- Torque mounting structure bolts:
 - Primary mounting structure bolt torque: 80ft-lb
 - Secondary mounting structure bolt torque: 20ft-lb
- Draw pre-aim orient line on fixture end of extension plate if desired. See fixture installation manual for more information.
- Set fixture driver box on top of fixture end of extension plate so that fixture primary bolt hole aligns with driver box primary bolt hole. NEVER install fixture driver box underneath extension plate.
- Install fixture primary bolt, washers, and nut as shown to secure fixture to extension plate.
- Orient fixture driver box as necessary for rough aiming. See fixture installation manual for more information.
- Install fixture secondary bolt through one of the three fixture secondary bolt holes and tighten securely.
- Torque fixture bolts:
 - Primary fixture bolt torque: 80ft-lb
 - Secondary fixture bolt torque: 20ft-lb

Extension Plate Kit (EXTPLT) with Additional (HRDM58) Mounting Fastener Hardware Kit

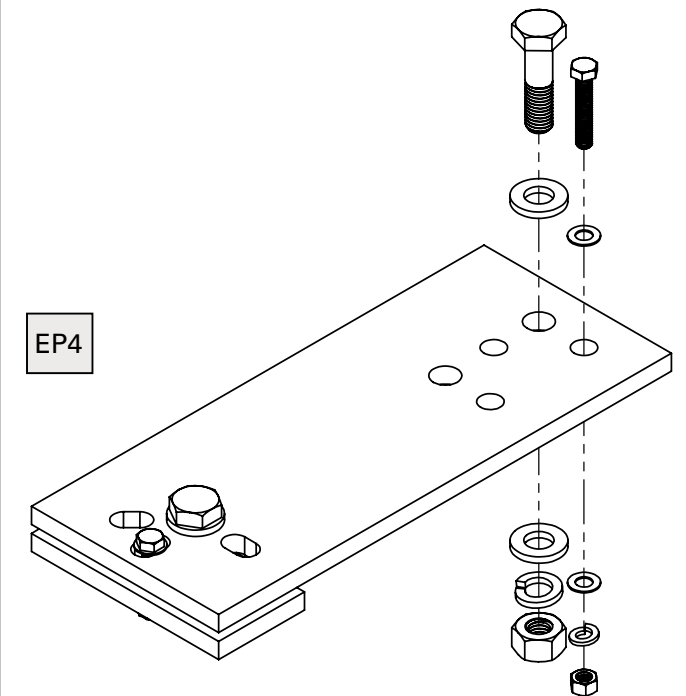



Maintenance & Preventative Maintenance

Fixture Care and Maintenance

All light heads are prepared with a powder-coated finish. The finish on exterior light heads may weather over time, depending on the environmental conditions at the installation site. Proper care of the light heads will maintain their performance and appearance.

Follow a regular maintenance schedule to retain optimal light output and thermal performance. Lack of preventative maintenance may disqualify owner from warranty. Not adhering to this minimum system cleaning requirement is considered negligence as outlined in your product warranty documents. Refer to your product and/or labor warranty documentation for further details.



Always disconnect power from the luminaire before opening the driver box.

Cleaning

1. Clean all luminaires at a minimum of once every 12 months from receipt of your product.
2. Remove physical elements such as dirt, leaves and other foreign debris from the luminaire housing that can block and modify the air cooling (heatsink fins)
3. Wipe the optical lenses with a clean, dry, cotton cloth to remove dust and other contaminants. A non-abrasive optical cleanser or water may be used periodically.
4. Do not apply cleaners in direct sunlight or at elevated temperatures

Inspection of Hardware

Inspect mounting system and products at least once every 12 months. Replace all rusted hardware elements.



Troubleshooting

The Ephesus light head is designed to provide many years of reliable quality lighting. If the system appears to not be operating correctly, perform the following steps:

Gather Data

The first step is always to find out as much about the issue as possible. Ask the following questions:

1. **How many fixtures are not operating correctly?** If only one fixture is not responding, continue investigating at that fixture itself. If a group of fixtures are not responding correctly, start at the source of the power or controls for that group.
2. **Have any obvious external forces been in the area?** For instance, were any riggers, electricians, or other workers near the fixtures or controls? Have there been any power disturbances in the facility such as lightning storms?
3. **Are your fixtures responding according to the input control function?** Run the system through some different control scenes, including all on and then all off (blackout mode). Take note of any fixtures not responding correctly to the scenes.

Problem	Remedy
Does not power on	<ul style="list-style-type: none"> • Verify the Distribution Box has AC power • Verify proper wiring to the Distribution Box, PAC Boxes and Light heads • Check electrical connections at the light head/crossarm, drop cable/ Distribution Box, and Distribution Box/PAC Box interfaces. • Verify control signal is above 50%.
Does not respond to controls	<ul style="list-style-type: none"> • Reset the fixture by turning all power sources off for at least 10 seconds. • Inspect all system control wiring to make sure there are no poor connections or breaks in the control wiring. • If its airmesh controllable fixture, then check connectivity of gateway with nodes and resend the command.

Fixture Replacement

Contacting Warranty Technical Support

1. Before you call, make sure you have completed the troubleshooting steps.
2. Gather as much detailed information as possible about the situation.
3. Have your fixture and project information handy, including the model number of the fixture in question.

Refer to your fixture warranty document for more information

If you have attic stock fixtures available and need to replace a fixture, simply follow the installation instructions in this manual to replace the fixture in question. Be sure to address the replacement fixture with the correct luminaire number.

All Luminaires, materials, and accessory equipment being returned through the warranty process need to be placed back in their original packaging in the same orientation that they were originally shipped from the factory. If the packaging is damaged or if there are questions on the orientation in returning equipment and materials, you need to contact the Warranty Department for replacement packaging materials at:

EphesusWarranty@Signify.com | +1 (800)-573-3600



Warranties and Limitation of Liability

Please refer to www.cooperlighting.com/global/resources/legal for our terms and conditions.