

Installation Instructions - Corelite Discreet Suspended LED

WARNING



Risk of Fire, Electrical Shock, Cuts or other Casualty Hazards- Installation and maintenance of this product must be performed by a qualified electrician. This product must be installed in accordance with the applicable installation code by a person familiar with the construction and operation of the product and hazards involved.



Risk of Fire and Electric Shock- Make certain power is OFF before starting installation or attempting any maintenance. Disconnect power at fuse or circuit breaker.



Risk of Fire- Minimum 90°C supply conductors.



Risk of Burn- Disconnect power and allow fixture to cool before handling or servicing.

Risk of Personal Injury- Due to sharp edges, handle with care.

Failure to comply with these instructions may result in death, serious bodily injury and property damage.

DISCLAIMER OF LIABILITY: Cooper Lighting Solutions assumes no liability for damages or losses of any kind that may arise from the improper, careless, or negligent installation, handling or use of this product.

IMPORTANT: Read carefully before installing fixture. Retain for future reference.

NOTICE: Green ground screw provided in proper location. Do not relocate.





NOTICE: Fixture may become damaged and/or unstable if not installed properly.

Note: Specifications and dimensions subject to change without notice.





ATTENTION Receiving Department: Note actual fixture description of any shortage or noticeable damage on delivery receipt. File claim for common carrier (LTL) directly with carrier. Claims for concealed damage must be filed within 15 days of delivery. All damaged material, complete with original packing must be retained.











Wiring Table

OLD

Power Supply (Input)	
	Black (BK) - Hot
	White (WT) - Neutral
	Green (GN) - Ground
	Violet (VT) - Dimming (+)
	Gray (GY) - Dimming (-)

NEW

Power Supply (Input)	
	Black (BK) - Hot
	White (WT) - Neutral
	Green (GN) - Ground
	Violet (VT) - Dimming (+)
	Pink (PK) - Dimming (-)

Power Supply (Input) - When Applicable	
	Black/Red (BK/RD) - Emergency Hot
	White/Red (WT/RD) - Emergency Neutral
	Black/Orange (BK/OR) - 2nd Circuit Hot
	White/Orange (WT/OR) - 2nd Circuit Neutral
	Orange (OR) - 2nd Circuit Dimming (+)
	Yellow (YL) - 2nd Circuit Dimming (-)
	Blue (BL) - Battery/Emergency Unswitched Hot
Vivid Tune	
	Violet/White (VT/WT) - 1st Circuit CCT (+)
	Gray/Black (GY/BK) - 1st Circuit CCT (-)
	Black/White (BK/WT) - 2nd Circuit CCT (+)
	White/Yellow - 2nd Circuit CCT (-)

Please note: The grey dimming wire will be changed to a pink wire in 2022.

Recommended Equipment:

- Hammer
- 1/4" nut driver
- Flathead screwdriver
- Scissors or sharp cutting blade
- Gloves

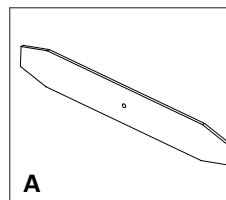

A

Biscuit Aligner

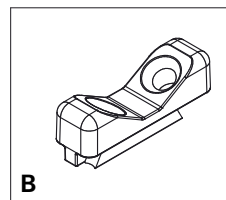

B

Cast joiner

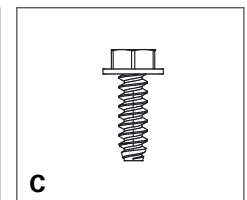

C

#8-18 x 1/2 HWH

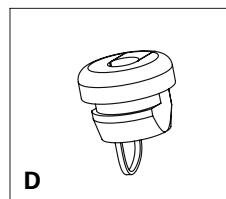

D

Strain Relief

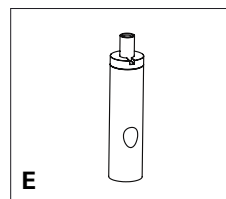

E

Cable Adjuster

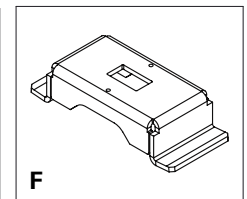

F

Cable Mount

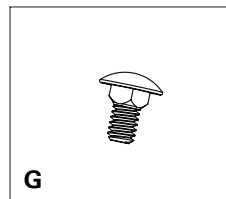

G

Carriage Bolt

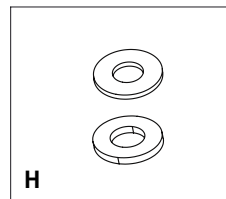

H

Washer Set

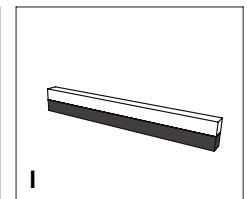

I

Baffle Gasket

Installation Instructions - Corelite Discreet Suspended LED

System Overview

SQ4 Joint Kit(s)

- (x2) Biscuit Aligners (A)
- (x2) Cast joiners (B)
- (x4) #8-18 x 1/2 HWH Screws (C)

NOTE: 1 kit required for each fixture-to-fixture joint

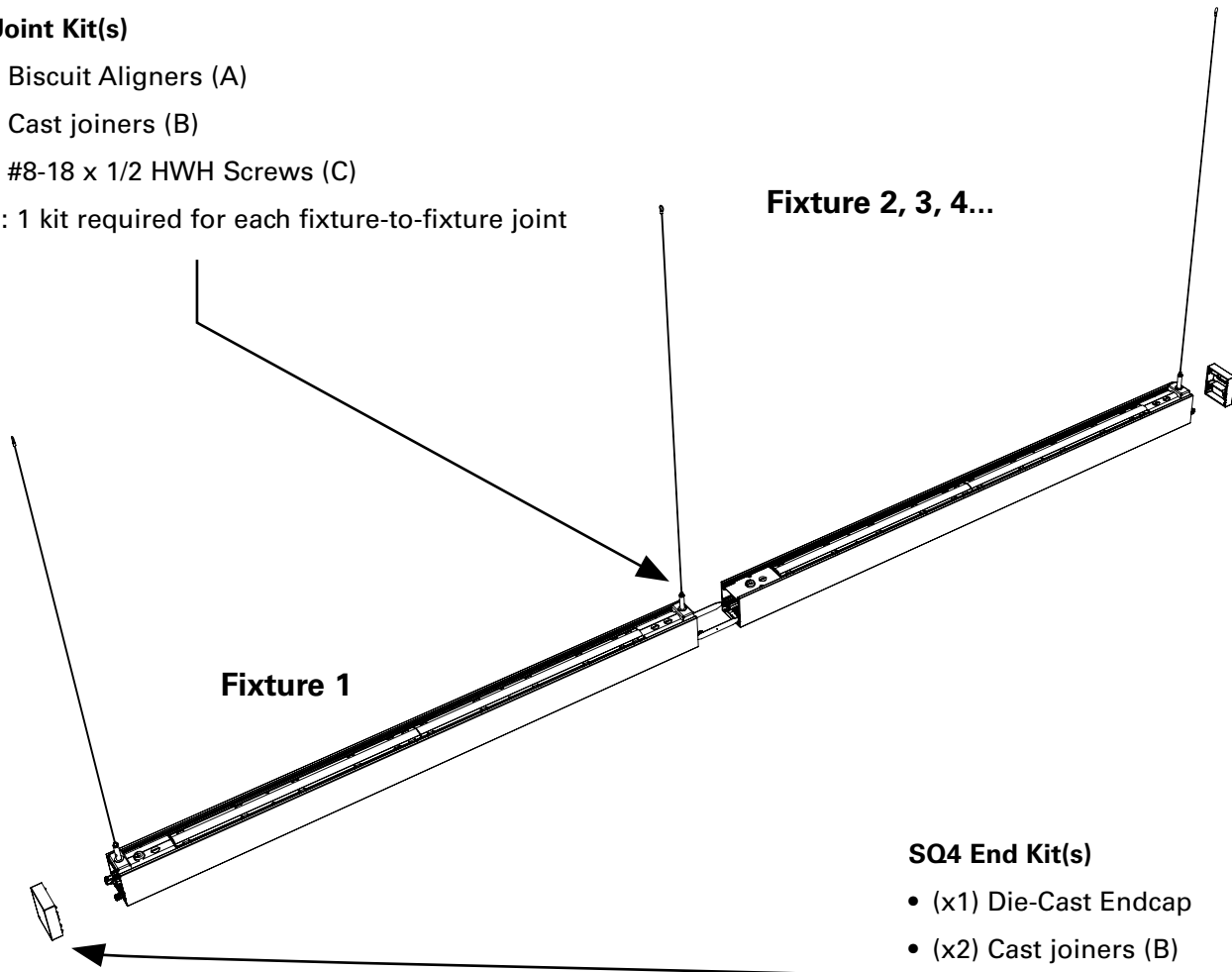

SQ4 End Kit(s)

- (x1) Die-Cast Endcap
- (x2) Cast joiners (B)
- (x4) #8-18 x 1/2 HWH Screws (C)

NOTE: 2 kits required for each run (one for each end)

Mount Spacing

Maximum distance of flexible mount location from end of unit: 1' for 4' unit, 1' for 6' unit, 2' for 8' unit 4' for 12' unit. Maximum distance between mounting points shall not exceed 12 feet.

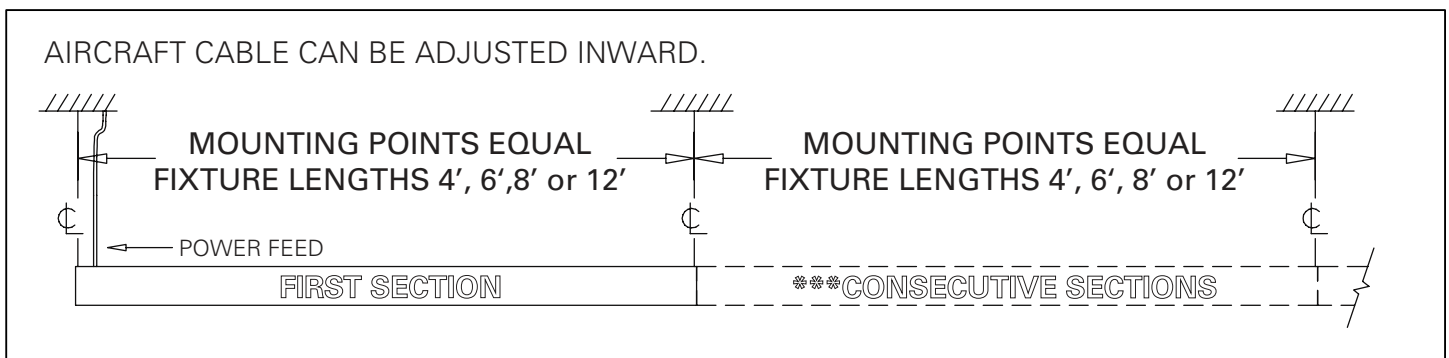

For installation at ceiling, see separate ceiling interface instructions.

Installation Instructions - Corelite Discreet Suspended LED

① Hardware Installation

The steps in this section can all be performed while the fixtures are at ground level.

Remove one baffle section from each end of every fixture.

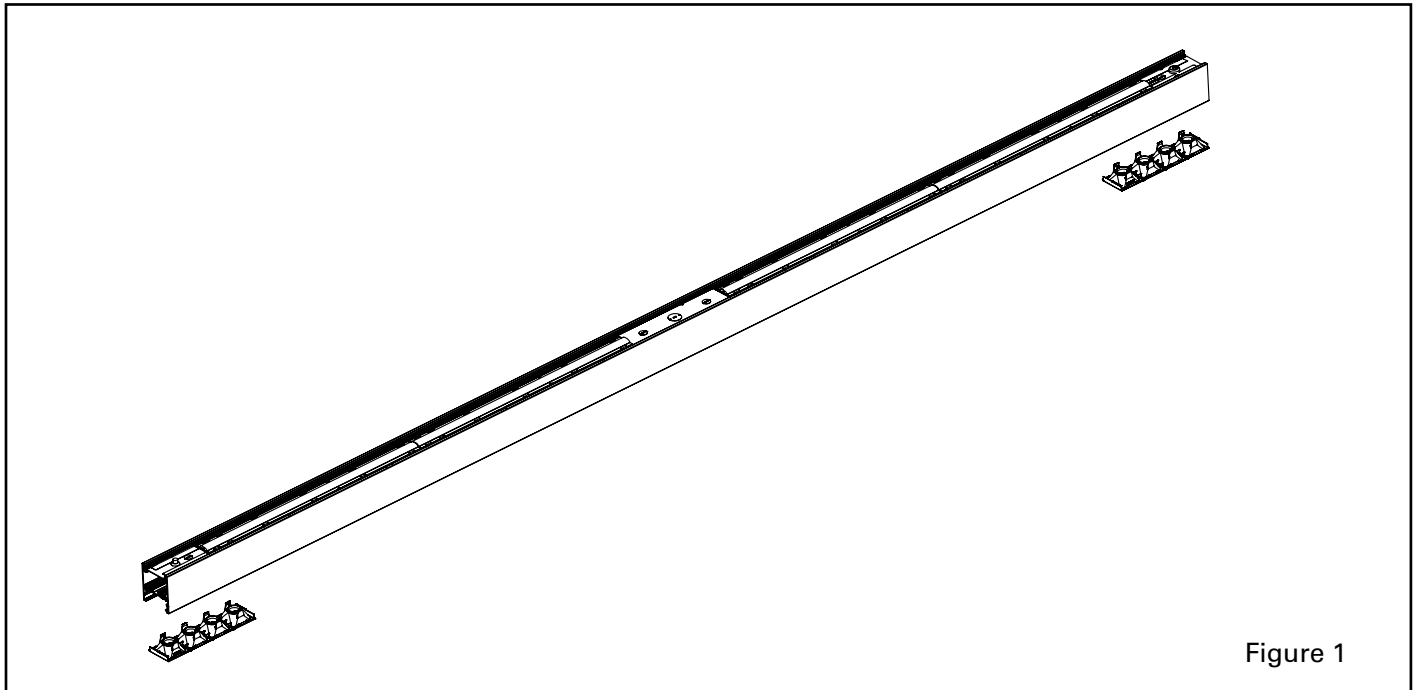

For beginning of run and intermediate fixtures, install 2 **biscuit aligners (A)** at on end, and 2 **cast joiners (B)** at the other.

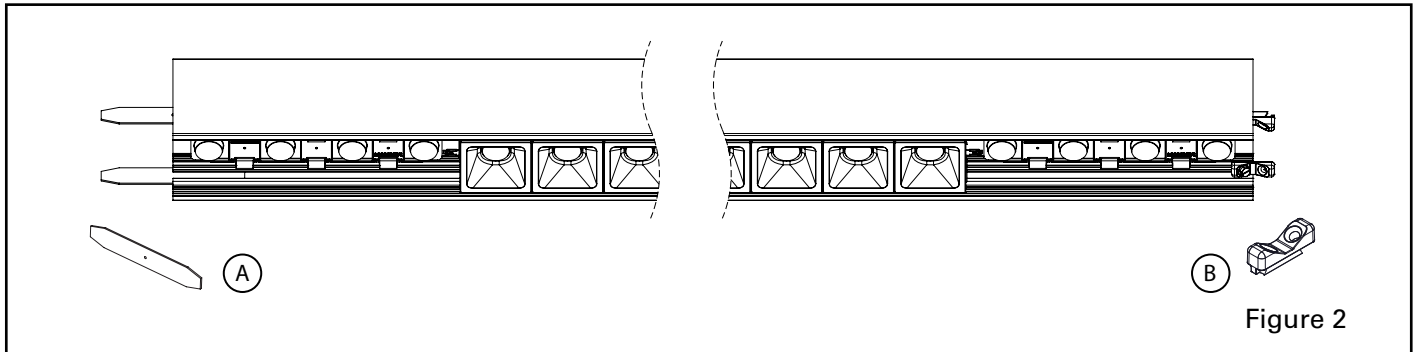

For end of run and individual fixtures, install 2 **cast joiners (B)** at each end of the fixture.

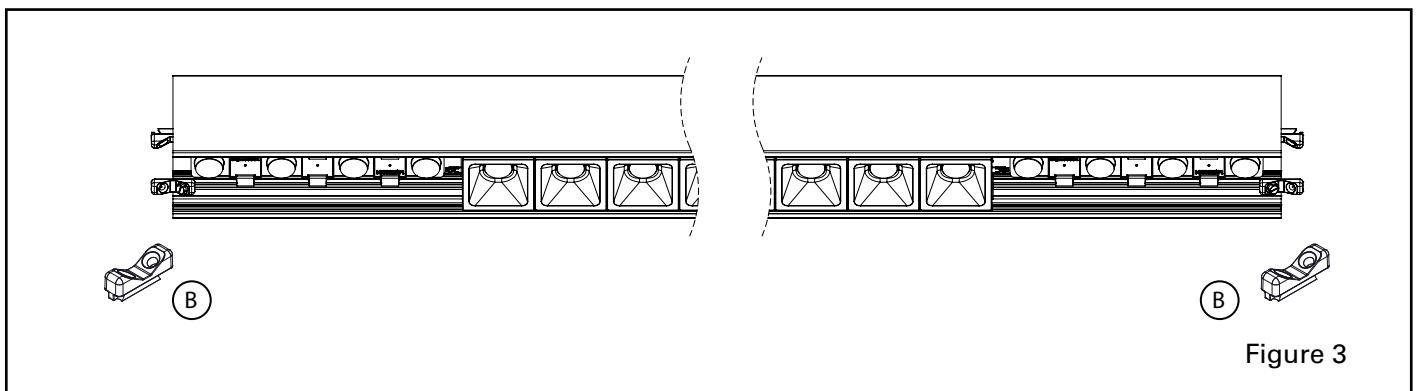

Installation Instructions - Corelite Discreet Suspended LED

Push **biscuit aligners A** into housing as shown below. Use a rubber mallet to seat the biscuits properly if required.

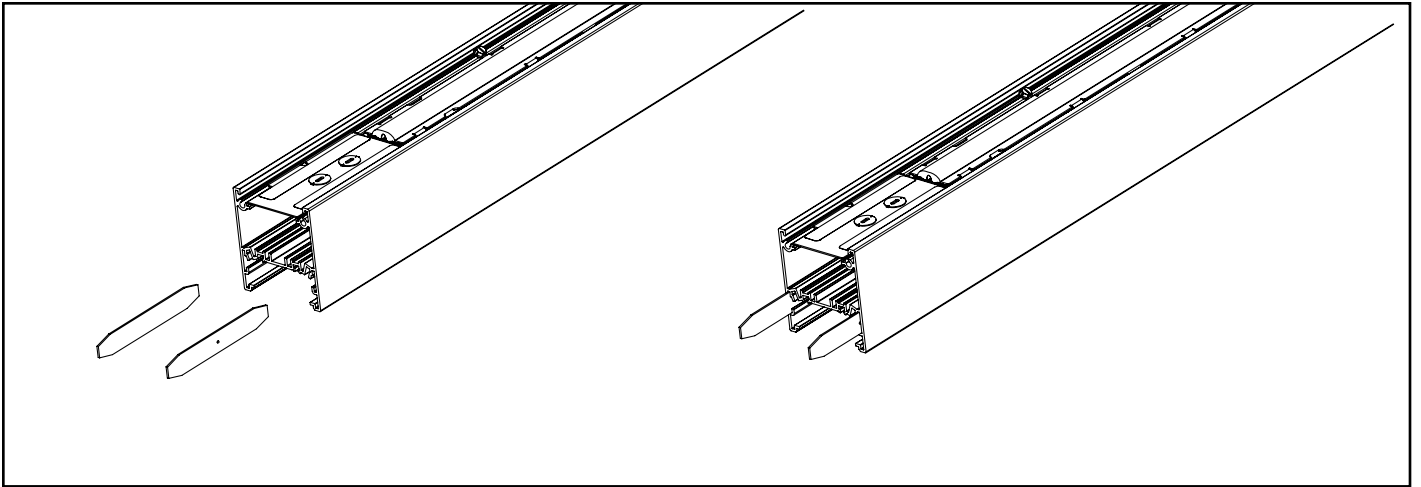

Slide **cast joiners B** half way into the housing and fasten with the provided screws **C**

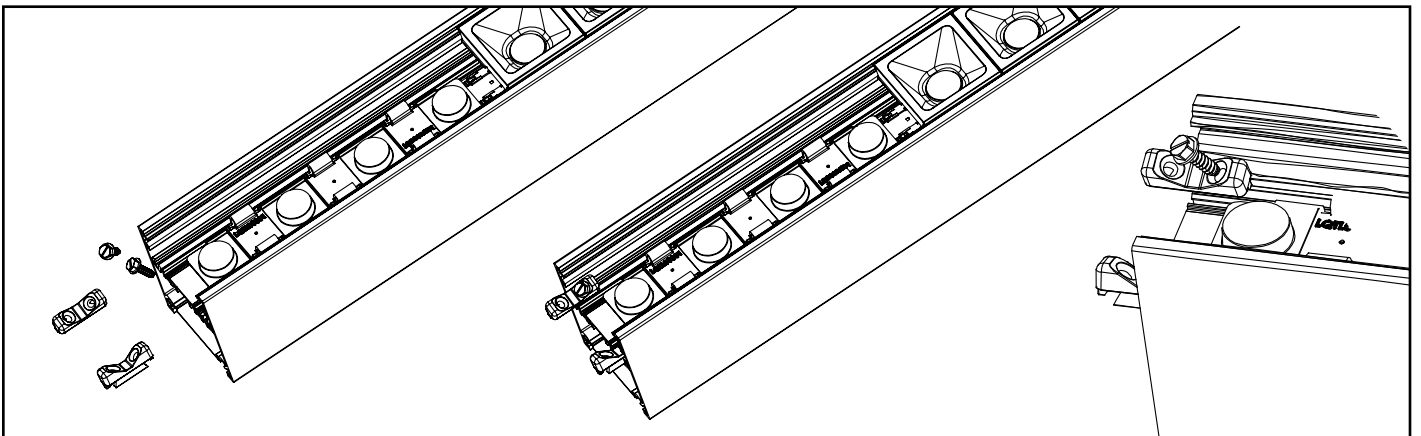

Remove electrical wiring access plate at one end of each fixture.

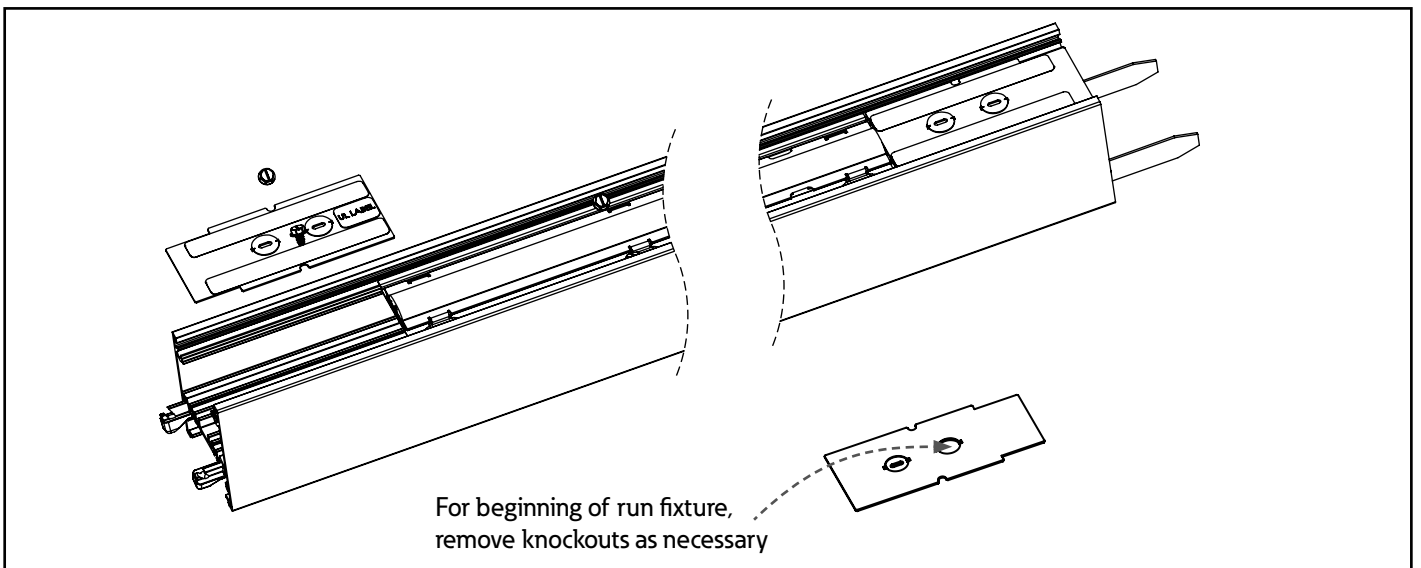

Installation Instructions - Corelite Discreet Suspended LED

② Aircraft Cable Mounting

Assemble the aircraft cable suspension bracket as shown below. Slide the assembly into the housing and temporarily insert one of the electrical access plate screws into the housing (as shown below) to prevent the assembly from sliding.

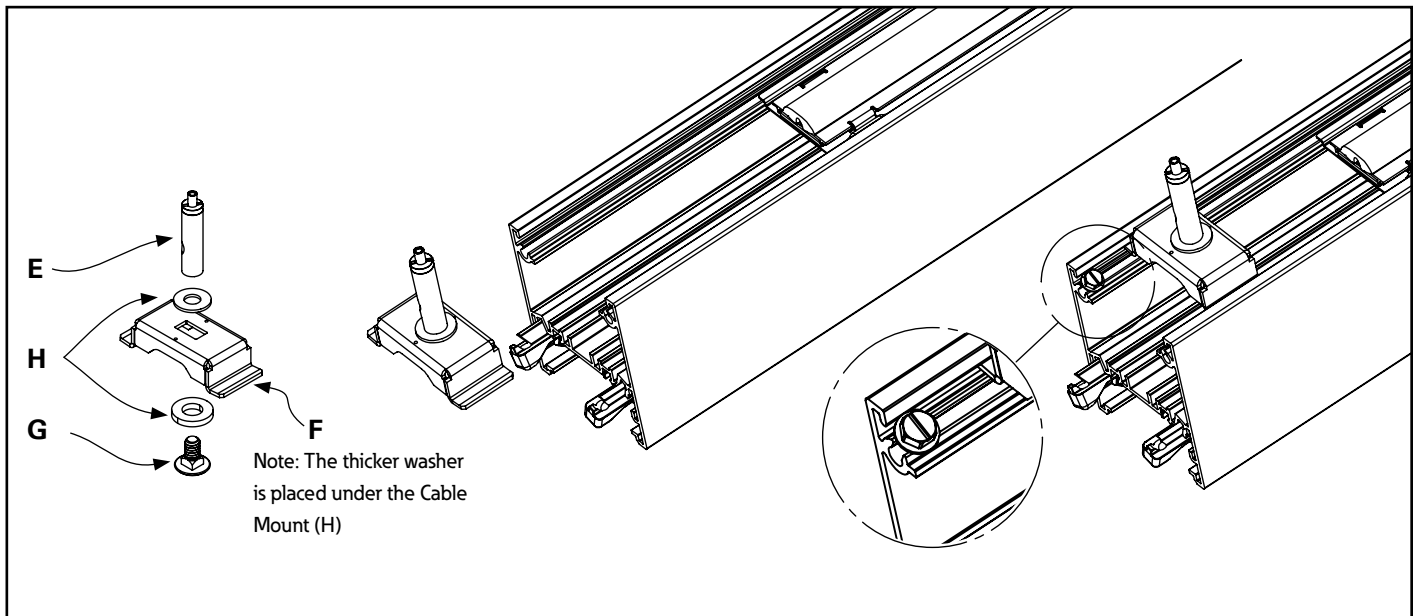

To prevent **cable mount(D)** slipping on the beginning of run fixture, the endcap can be attached to fixture using **cast joiners(B)** and the provided **#8-18 x 1/2 HWH screws(C)**.

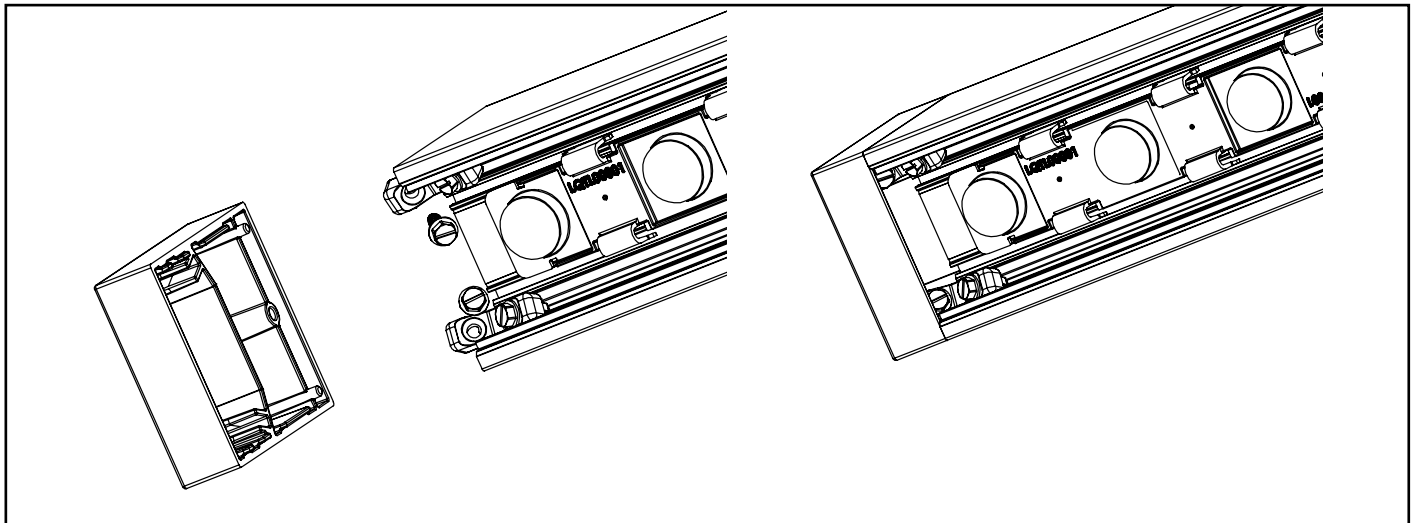

The fixture can now be suspended from the supplied aircraft cable.

Installation Instructions - Corelite Discreet Suspended LED

③ Power Drop

Remove the electrical access plate from the top of the fixture and wire fixture following the wiring chart shown on page 2. Once wiring is completed, re-attach the electrical access plate.

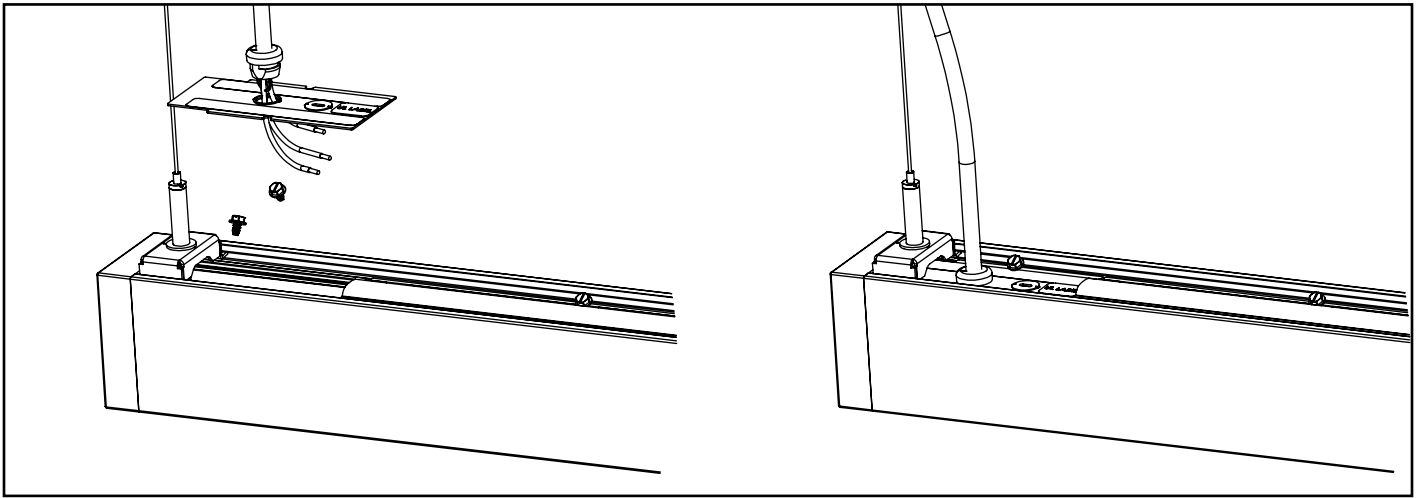

④ Joining

Slide next fixture onto hanging fixture until biscuit joiners engage. Make wiring connections and push wires into housing prior to sliding the fixtures firmly together. Then, re-attach the electrical access plate.

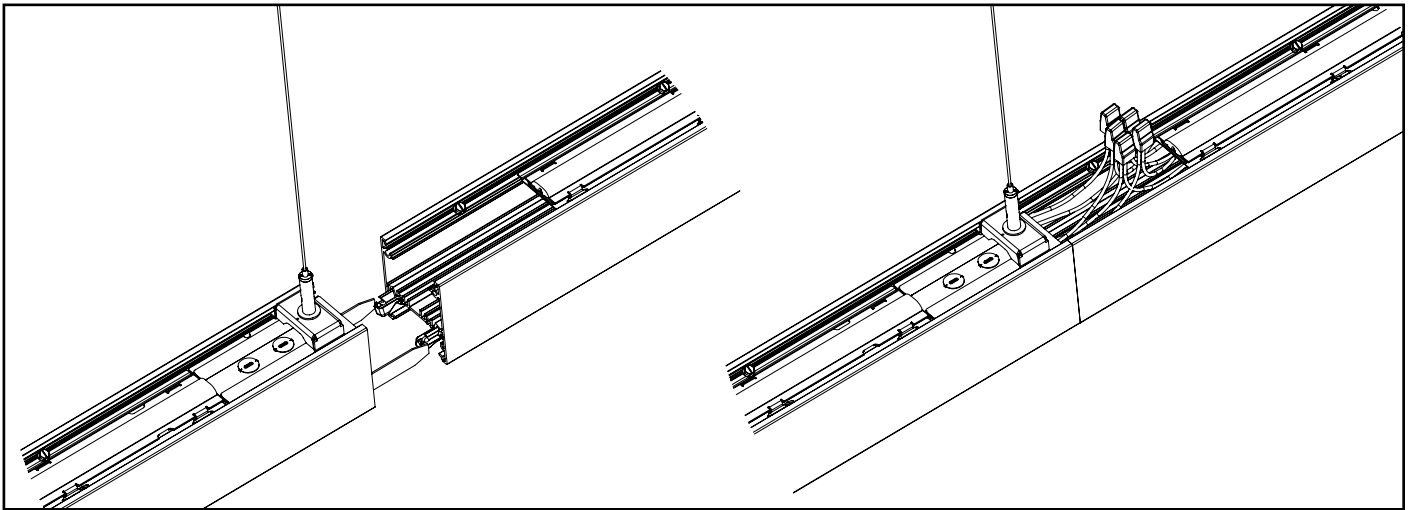

Once fixtures are together fasten joiners using the provided #8-18 x 1/2 HWH screws (C).

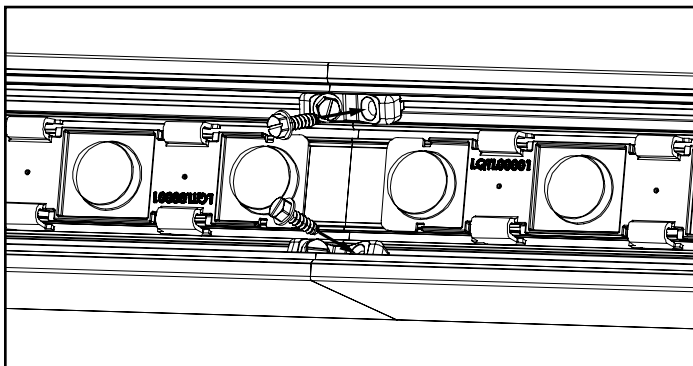

Installation Instructions - Corelite Discreet Suspended LED

Replace all baffles by snapping in to fixture.

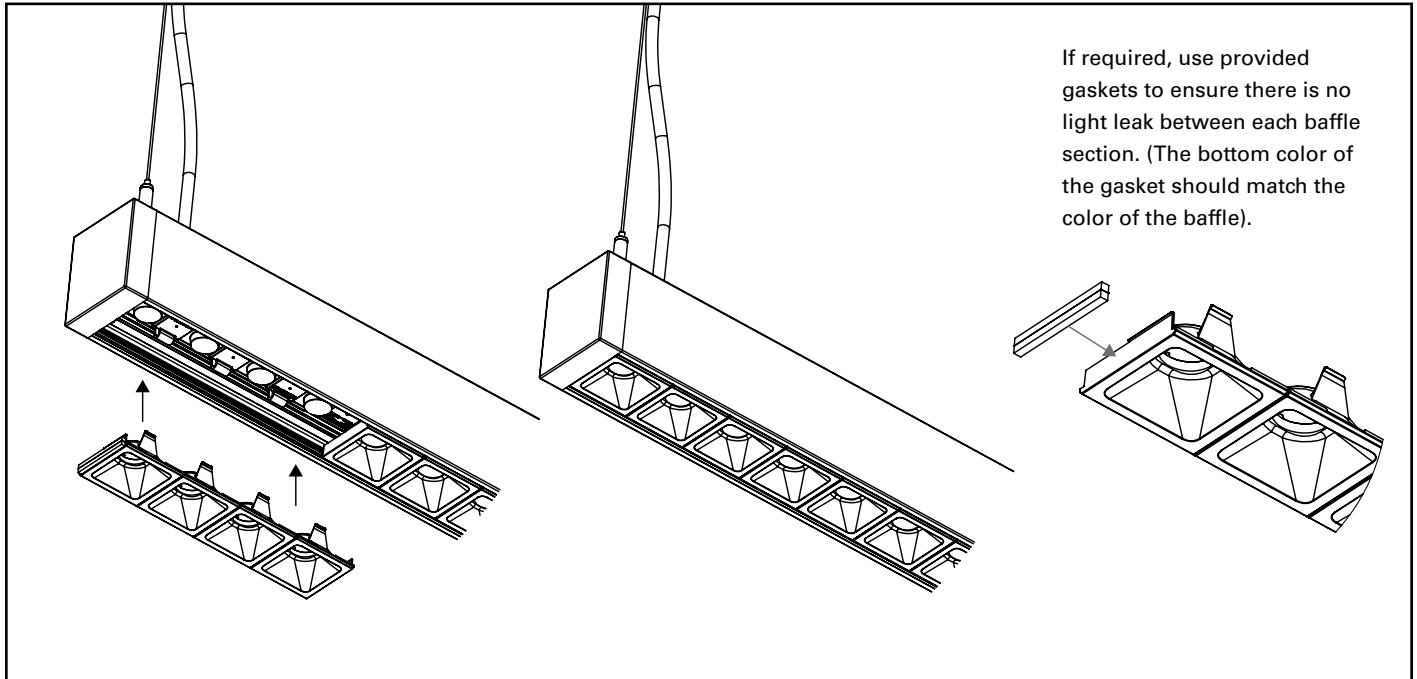

⑦ Sensor End Caps (if applicable)

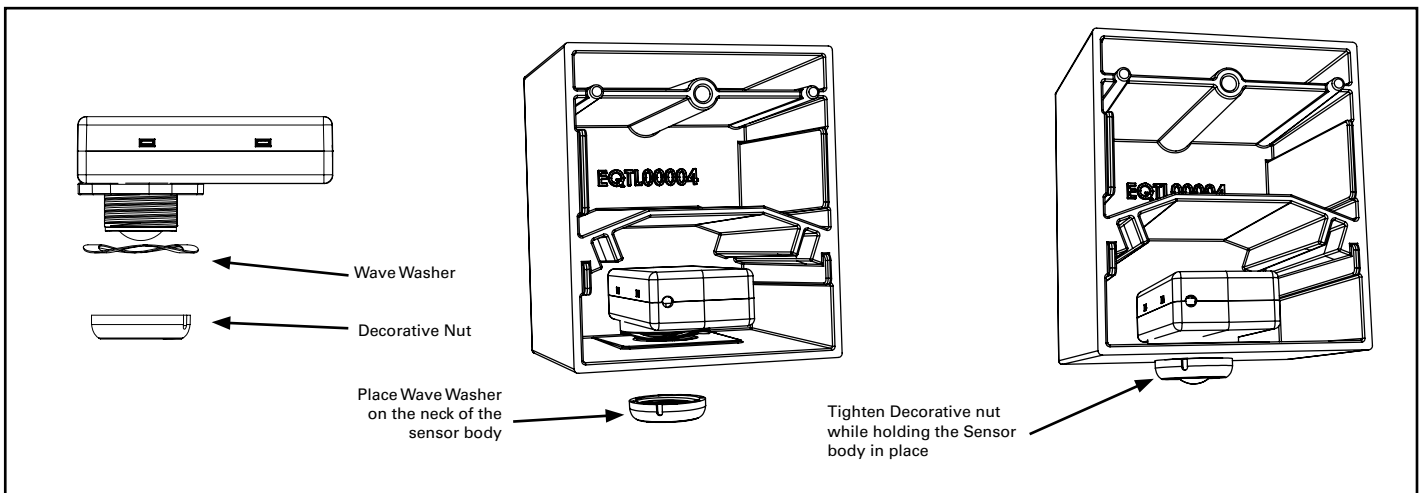

⑧ Fixture Maintenance and Cleaning

Always follow recommended cleaning and handling procedures when cleaning.

Fingerprints and large dust particles can be removed by gently wiping the surface with a clean microfiber cloth. If additional cleaning is required, it is recommended to use Clorox® wipes to remove remaining contaminants by gently rubbing the affected area and allowing to air dry.

Warranties and Limitation of Liability

Please refer to www.cooperlighting.com/WarrantyTerms for our terms and conditions.

Garanties et limitation de responsabilité

Veillez consulter le site www.cooperlighting.com/WarrantyTerms pour obtenir les conditions générales.

Garantías y Limitación de Responsabilidad

Visite www.cooperlighting.com/WarrantyTerms para conocer nuestros términos y condiciones.

FCC Statement

• This device complies with Part 15 of the FCC Rules. Operation is subject to the following two conditions:

- (1) This device may not cause harmful interference.
- (2) This device must accept any interference received, including interference that may cause undesired operation.

Note: The grantee is not responsible for any changes or modifications not expressly approved by the party responsible for compliance. Such modifications could void the user's authority to operate the equipment.

Note: The equipment has been tested and found to comply with the limits for a **Class B** digital device, pursuant to part 15 of the FCC Rules.

These limits are designed to provide reasonable protection against harmful interference in a residential installation. This equipment generates uses and can radiate radio frequency energy and, if not installed and used in accordance with the instructions, may cause harmful interference to radio communications. However, there is no guarantee that interference will not occur in a particular installation. If this equipment does cause harmful interference to radio or television reception, which can be determined by turning the equipment off an on, the user is encouraged to try to correct the interference by one or more of the following measures:

- Reorient or relocate the receiving antenna.
- Increase the separation between the equipment and receiver.
- Connect the equipment into an outlet on a circuit different from that to which the receiver is connected.
- Consult the dealer or an experienced radio/TV technician for help.

This device complies with FCC radiation exposure limits set forth for an uncontrolled environment. This equipment must be installed and operated in accordance with provided instructions and the antenna(s) used for this transmitter must be installed to provide a separation distance of at least 20 cm from all persons.