

Project		Catalog #		Type	
Prepared by		Notes		Date	

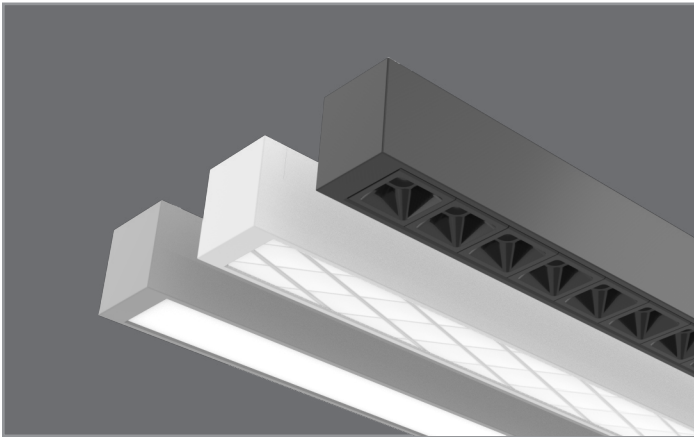

# Corelite

## Continua™ SQ2



LED  
Suspended  
Direct, Direct/Indirect

### Typical Applications

- Office • Education • Healthcare • Hospitality • Retail

### Interactive Menu

- Order Information [page 2](#)
- Photometric Data [page 5](#)
- Energy and Performance Data [page 3](#)
- Control Systems [page 11](#)
- Product Warranty

### Product Certification



### Product Features



### Top Product Features

- Available in 2', 4', 6', 8', 12' lengths as well as continuous runs
- Suspended, recessed, surface and wall mount applications
- Wide range of direct/indirect distributions and independent up/down circuiting
- Available with two high performance low glare optical options
- Best in class 110° peak candela indirect batwing optic for maximizing ceiling uniformity and on-center spacing
- Up to 127 lumens per watt Direct-Indirect, 121 lumens per watt Direct
- Integrated control available - WaveLinx Pro, WaveLinx Lite, Wavelinx CAT
- Options to meet Buy American Act requirements

### Dimensions

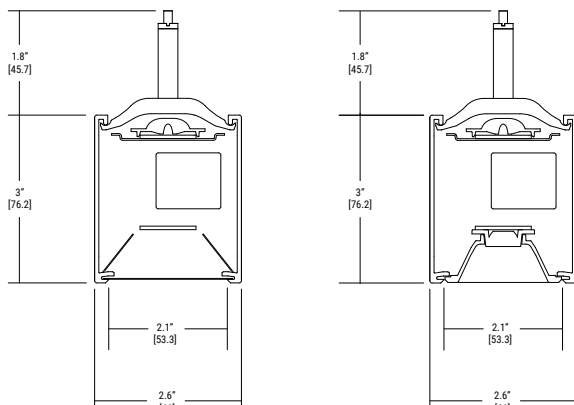

### Bottom Views

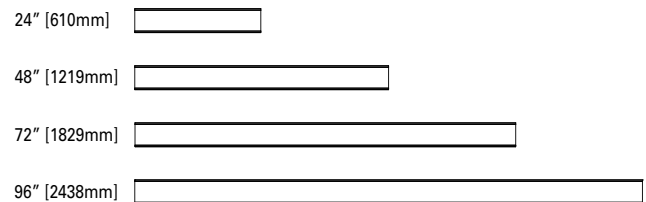

Note: End caps add .75" at each end. Sensor end caps add 1.5".

**Order Information**

SAMPLE ORDER NUMBER: **BAA-SQ2-BBN-075U-075D-L930-2D-UNV-STD-W-AC48-T9-8**

**Icon Key:** Grey bar denotes available with 10-Day Quick Spec  
 ∅ Consult factory for availability

Domestic Preferences	Series	Shielding (Direct)	Distribution (Direct)	Lumen Package Up (Lms/ft)	Lumen Package Down (Lms/ft)	CRI/CCT
<b>[Blank]</b> =Standard <b>BAA</b> =Buy American Act	<b>SQ2</b> = Continua SQ 2" Suspended	<b>Continuous Roll Lens</b>  <b>F</b> =Frosted Continuous Roll Lens  <b>PP3</b> = Perceive Prism <b>PW1</b> = Perceive Waves <b>PR1</b> = Perceive Ripple <b>PH1</b> = Perceive Hex  <b>Discreet Optics™</b>  <b>BB</b> = Black Discreet™ Baffle, TIR Optic <b>WB</b> =White Discreet™ Baffle, TIR Optic	<b>Continuous Roll Lens</b>  <b>[Blank]</b> =Standard Lambertian Distribution <b>B</b> = Frosted Continuous Batwing Roll Lens <b>A</b> = Frosted Continuous Asymmetric Roll Lens  <b>Discreet Optics™</b>  <b>M</b> =Medium, 80° <b>N</b> = Narrow, 35°	<b>0U</b> =No Uplight <b>025U</b> =250 Lumens/ft Up <b>050U</b> =500 Lumens/ft Up <b>075U</b> =750 Lumens/ft Up <b>100U</b> =1000 Lumens/ft Up <b>125U</b> =1250 Lumens/ft Up <b>150U</b> =1500 Lumens/ft Up <b>U</b> =Specify **	<b>050D</b> =500 Lumens/ft Down <b>075D</b> =750 Lumens/ft Down <b>100D</b> =1000 Lumens/ft Down <b>125D</b> =1250 Lumens/ft Down <b>D</b> =Specify **	<b>830</b> =3000K, 80CRI <b>835</b> =3500K, 80CRI <b>840</b> =4000K, 80CRI  <b>930</b> =3000K, 90CRI <b>935</b> =3500K, 90CRI <b>940</b> =4000K, 90CRI
<b>Notes</b> Only product configurations with this designated prefix are built to be compliant with the Buy American Act of 1933 (BAA). Please refer to DOMESTIC PREFERENCES website for more information. Components shipped separately may be separately analyzed under domestic preference requirements.	<b>Notes</b>	<b>Notes</b> Please choose either Continuous roll lens or Discreet baffles. Continuous roll lens options are only available with other continuous roll lens options. Similarly, Discreet options are only available with Discreet baffles.  <b>F, FB, FA, PP3, PW1, PR1, PH1:</b> Seamless illumination with continuous roll lens.  BB or WB Discreet baffles only available with 90 CRI.	<b>Notes</b> Please choose either Continuous roll lens or Discreet baffles. Continuous roll lens options are only available with other continuous roll lens options. Similarly, Discreet options are only available with Discreet baffles.  <b>F, FB, FA, PP3, PW1, PR1, PH1:</b> Seamless illumination with continuous roll lens.	<b>Notes</b> Custom lumen output available. Up (Indirect): Min = 250 Lms/ft Max = 1500 Lms/ft  ** Consult factory to specify custom lumen package  Not all lumen packages are available for every configuration. See Driver Availability tables for more details.	<b>Notes</b> Custom lumen output available. Down (Direct): Min = 150 Lms/ft Max = 1500 Lms/ft  Consult factory to specify custom lumen package  Not all lumen packages are available for every configuration. See Driver Availability tables for more details.	<b>Notes</b> Discreet Baffles only available with 90 CRI

Circuiting (In Cross Section)	Specialty Wiring	Voltage	Driver/Dimming Options	Integral Sensor Options	Integral Emergency Device Options
<b>1</b> =Single Circuit <b>2</b> =Dual Circuit (Ind. Up/Down Circuits)	<b>D</b> =None (Default Dimming) <b>E</b> =Emergency Circuit <b>S</b> =Secondary Circuit <b>N</b> =Secondary + Emergency Circuit	<b>UNV</b> =Universal (120V-277V) <b>347</b> =347V	<b>STD</b> =Standard 0-10V (1%-100%) <b>5LT</b> =Fifth Light DALI (1%-100%) <sup>(A)</sup> <b>LH</b> =Lutron HiLume (LDE1 series) 1%-100% EcoSystem Driver with Soft-on Fade to Black dimming <sup>(B)</sup>	<b>[Blank]</b> =No Sensor <b>WPS</b> =WaveLinX Pro Wireless Integrated Sensor ∅, <sup>(A)</sup> <b>WLS</b> =WaveLinX LITE Wireless Integrated Sensor ∅, <sup>(B)</sup>	<b>B06</b> =6-watt, 120V-277V Emergency Battery Pack <b>EPC</b> =LVS Controls EPC UL924 Bypass Relay Device <b>B10</b> =10-watt, 120V-277V Emergency Battery Pack
<b>Notes</b> Refers to wiring in cross section. Dual circuit not available with secondary circuit or integrated sensor.	<b>Notes</b> Emergency and Secondary circuit section wiring are configured per unit (4ft, 6ft, 8ft, or 12ft).	<b>Notes</b> Integral 347V driver with STD 0-10V option only.	<b>Notes</b> (A) Not all driver options are available for every configuration. See Driver Availability tables for more details. (B) For driver details consult www.lutron.com	<b>Notes</b> (∅) Must be used with STD driver. Integrated options must be used in conjunction with the associated system and may not be compatible with other options or accessories. Please refer to the following: (A) Consult WaveLinX PRO system pages for additional details and compatibility. (B) WaveLinX LITE devices are not currently compatible with the WaveLinX Wireless Area Controller. Consult WaveLinX LITE system pages for additional details and compatibility.	<b>Notes</b> Battery operates entire downlight portion of 4ft and 6ft fixtures. Battery operates specified 4ft sections of 8ft and 12ft fixtures. Battery available in fixtures up to a combined 2000 lms/ft. EPC option used to bypass local control during outage. Must be used in conjunction with UL 1008 device (provided by others). 4ft Fixture with uplight not available with integrated battery and sensor in same fixture. 4ft Fixture with uplight not available with integrated battery and 5LT drivers in same fixture

Finish	Suspension Type	Ceiling Type	Run Length
<b>W</b> =White <b>S</b> =Silver <b>B</b> =Black <b>CC</b> =Classic RAL <b>CM</b> =Color Match	<b>AC48</b> =48" Aircraft cable <b>AC120</b> =120" Aircraft cable <b>AC240</b> =240" Aircraft cable <b>AC360</b> = 360" Aircraft cable	<b>T1</b> =15/16" T-Bar <b>T9</b> =9/16" T-Bar <b>TS</b> =Slotted T-Bar <b>JB</b> =Junction Box / Structure <b>UM</b> =Universal Ceiling Kit (T1, T9, JB) <b>S</b> =Swivel at Canopy (S = T1, T9, TS or JB)	<b>2</b> =2 ft <b>4</b> =4 ft <b>6</b> =6 ft <b>8</b> =8 ft <b>12</b> =12 ft <b>XX</b> =Specify Run Length
<b>Notes</b> <b>CC</b> =must denote RAL color number Consult factory for custom finishes. <b>CM</b> = Color match(additional fee) requires color sample to be sent to the factory. CM pricing does not include metallic, flake or specialty texture finishes. Please consult factory for specialty finishes	<b>Notes</b>	<b>Notes</b> UM mounting accomodates 15/16" Grid, 9/16" Grid, 4" Octagonal J-Box, and Structure. White mounting hardware standard. For black mounting hardware, add "B" after ceiling type. (e.g. T1-B).	<b>Notes</b> See "Standard Row Configurations" table on Page 13 for continuous row length breakdowns.  2ft not available with integral sensors or emergency.



## Product Specifications

### Construction

- Single-piece extruded aluminum housing
- 2.63" x 3" profile
- Die-formed 20 gauge cold rolled steel LED tray
- Driver accessible from above while fixture is suspended

### End Caps

- Die cast aluminum end caps with machined outer surfaces for precision alignment to housing
- Attach mechanically to the end of the fixture without exposed fasteners
- Standard end cap adds 0.8" at each end. Integrated sensor end cap adds 2.3" at each end

### Lengths

- Available in 2-ft, 4-ft, 6-ft, 8-ft, and 12-ft sections
- Modular design eliminates the need for starter, intermediate, and end of run sections
- See table on page 13 for standard continuous row length breakdowns

### Finish

- Electrostatically applied polyester powder coat paint
- White, silver, and black finishes are standard.
- RAL custom colors are available

### Mounting

- Aircraft cable mounts on 2'-0", 4'-0", 6'-0", 8'-0", or 12'-0" centers, equal to the respective unit length
- Aircraft cable mount centers are 1/2" from ends of fixture/run.
- Can be adjusted along the length of the fixture to match existing mounting points. See Installation Instructions for more details
- Can be adjusted along the width for balancing.
- Minimum suspension height from ceiling to top of fixture is 4"
- Fixture can be leveled at mounting bracket
- All sections are continuously wired with push-in connectors for fast installation
- Fixtures can be joined for straight continuous runs using supplied alignment brackets/pins and internal cast joiners
- Refer to installation instructions for various ceiling interface details

### Shielding

- **F:** Frosted continuous flexible roll lens creates seamless illumination along entire row length. Single piece roll lens up to 100 ft.
- **FB:** Frosted batwing continuous flexible roll lens creates seamless illumination along entire row length. Single piece roll lens is added to Diffuse roll lens up to 100ft.
- **FA:** Frosted Asymmetric continuous flexible roll lens creates seamless illumination along entire row length. Single piece roll lens is added to Diffuse roll lens up to 100ft.
- **BB(Black) and WB(White):** Injection molded, contoured, segmented baffles with for low UGR values and improved visual comfort.
- **PP3, PW1, PR1, PH1:** Proprietary Perceive™ optical system enables dynamic visual depth on a flat surface while providing glare-reducing performance with comfortable, high-quality illumination. Perceive continuous flexible roll lens creates seamless illumination along entire row length. Single piece roll lens is added to Diffuse roll lens up to 100ft.

### Optics

- Precision engineered TIR optics on upper and lower LED light engines for optimal light distribution and low glare
- 110° peak candela angle in indirect distribution
- 80° beam angle direct distribution with 45° cutoff

### LED and Light Engine

- LEDs are available in 3000K, 3500K, 4000K
- Continuous Roll lens is >\_80 CRI; Discreet optics are >\_90 CRI standard
- Baffle color, lens options and fixture color will affect lumen output - Please refer to the lumen adjustment tables on page 7
- TM21 life at 60,000 hours up to L85 and calculated theoretical L70 exceeds 135,000 hrs.
- Drivers available in 120-277V and 347V

### Integrated Controls

- 0-10V dimming to 1% standard
- WaveLinx sensor compatible for IoT capability
- DALI 2.0 and Lutron dimming available

### Emergency Options

- Emergency circuit option operates entire downlight portion of a specified unit (4 ft, 6 ft, 8 ft, or 12 ft)
- Optional 6 Watt or 10 Watt, 120-277V integral emergency battery
- Battery operates entire down-light portion of 4ft and 6ft fixtures. Battery operates down-light of 4ft sections of 8ft and 12ft Continuous Roll lensed and half of 8ft and 12ft Discreet fixtures
- 90-minute backup period for code compliance
- Test switch/indicator button located on the top side of the luminaire
- For approximate delivered lumens multiply the lumens per watt of the desired fixture by the wattage of the emergency battery pack (100 lm/W x 6 = 600 lumens)
- Battery is self-testing
- UL 924 emergency/generator transfer option, EPC, available and operates entire downlight portion of specified unit

### Weight

- 2.6 lbs. per foot

### Compliance

- cULus listed for damp locations
- Tested to IESNA LM-79 and LM-80
- RoHS compliant
- Stated life per TM21 standards
- Can be used for State of California Title 24 high efficacy luminaire

### Warranty

- Five year limited warranty standard  
[www.cooperlighting.com/legal](http://www.cooperlighting.com/legal)



## Dimensions

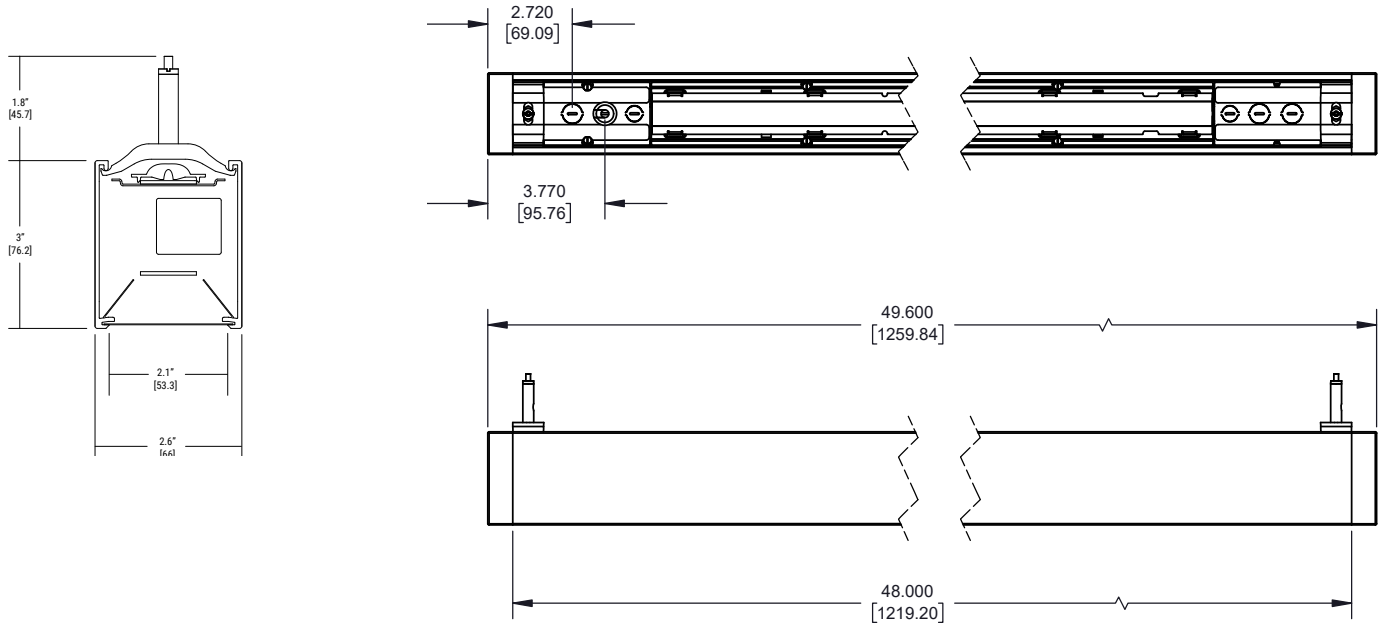



Continuous Lens

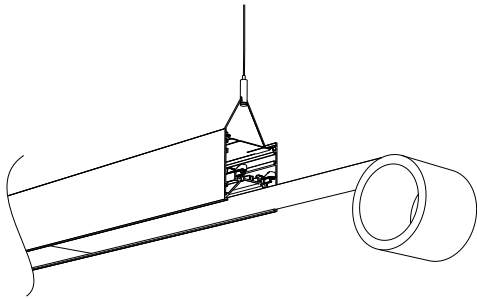

Adjustable Mounting

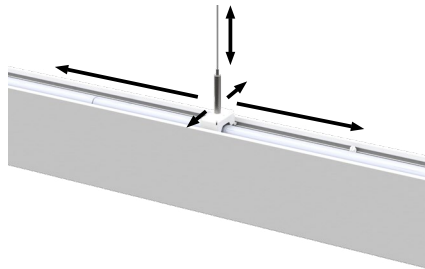

Discrete Optical System



Shielding & Finish Options

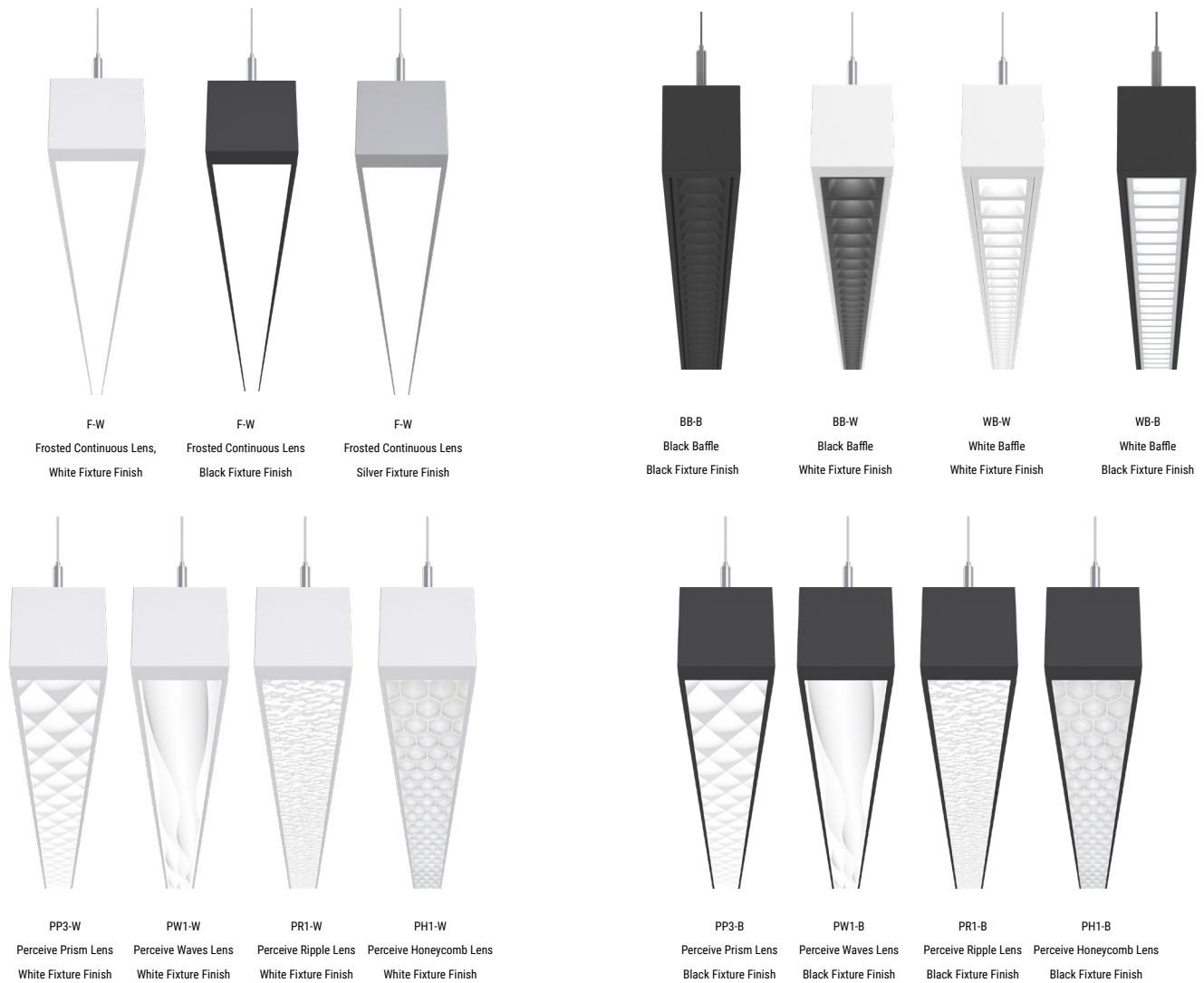

Note: All Finish and Shielding combinations are available. Not all are shown. Custom color housing finishes are also available.



Photometric Data

[View IES files](#)

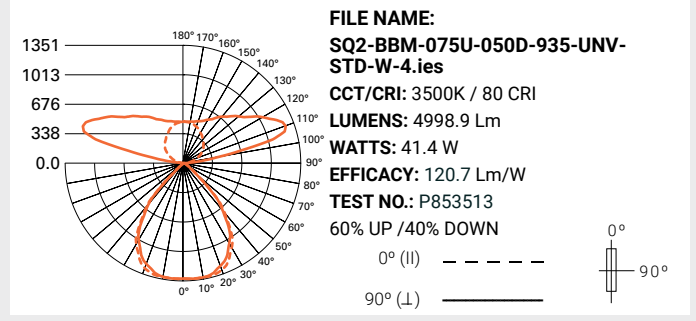
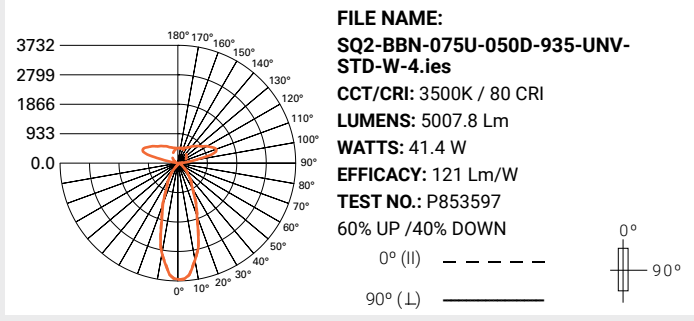
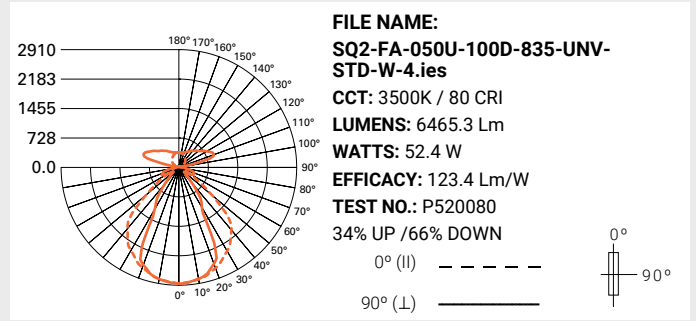
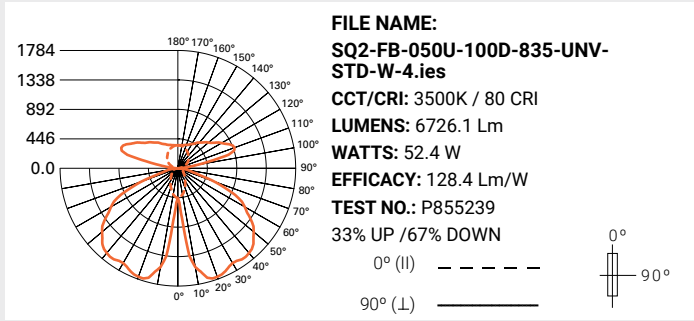
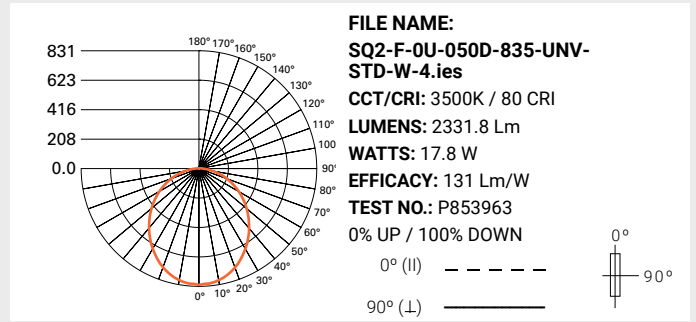
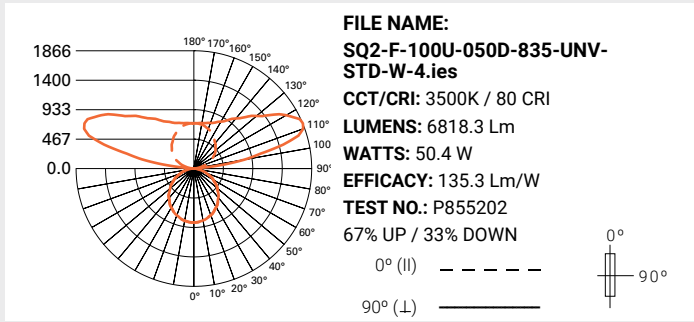

Photometric Data

[View IES files](#)

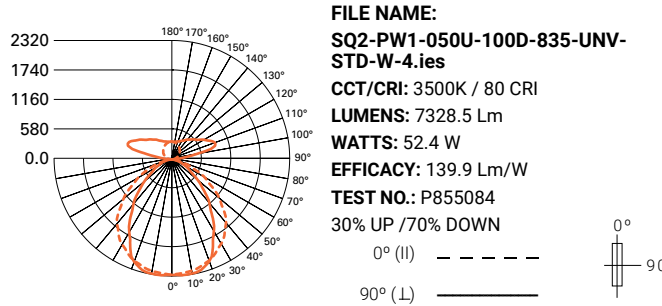
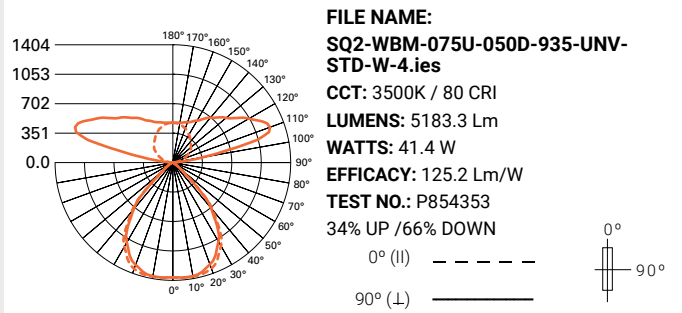
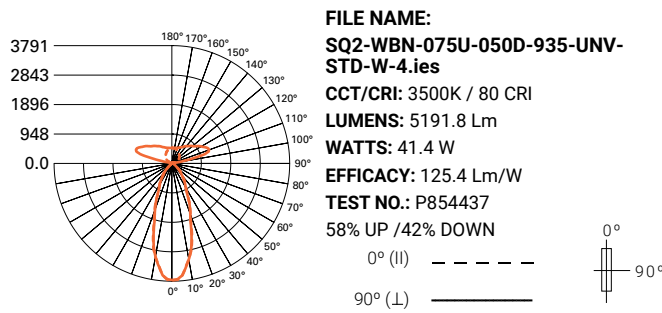

Note: Refer to IES files for more product data.

Lumen Maintenance

Ambient Temperature	TM-21 Lumen Maintenance (60,000 hours) <sup>(1)</sup>	Theoretical L70 (Hours) <sup>(2)</sup>
25°C	>84%	121,000

Notes: (1) Supported by IES TM-21 standards. (2) Theoretical values represent estimations commonly used; however, refer to the IES position on LED Product Lifetime Prediction, IES PS-10-18, that explains proper use of IES TM-21 and LM-80.

Color Data (3500K)

		80CRI	90CRI
TM-30-15	R <sub>f</sub>	84	89.7
	R <sub>g</sub>	97.2	97.2
CRI/CIE	R <sub>a</sub>	83.4	94.3
	R <sub>9</sub>	10.9	61.7

80CRI

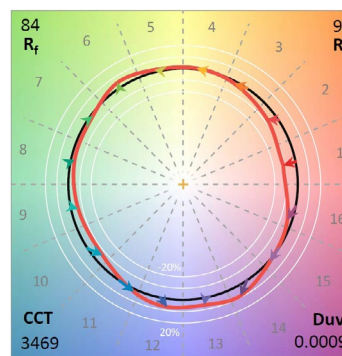

90CRI

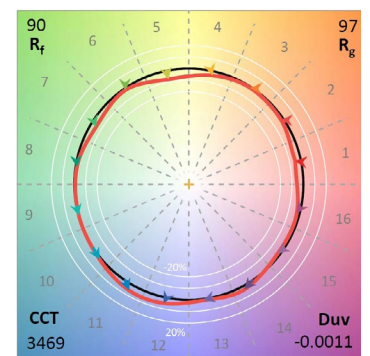

Energy and Performance Data - Frosted Lens (F)

Continua SQ2 Suspended Performance (3500K)							Glare		
Lumen Package	Lumens/ft Up	Lumens/ft Down	Lumens/ft Total	W/ft Total	Lm/W	Distribution (up%)	Distribution (down%)	UGR (1-2)(4-6)	MAX LUMINANCE (3-6)
0U-050D	0	2060	2060	4.5	115.8	0%	100%	24.7	10981
0U-075D	0	2972	2972	6.7	111.3	0%	100%	25.9	15842
0U-100D	0	3996	3996	9.4	106.3	0%	100%	27	21299
0U-125D	0	4976	4976	12.3	101.1	0%	100%	27.7	26521
025U-050D	1011	2061	3072	6.3	121.9	33%	67%	22.1	10981
025U-075D	1006	2973	3978	8.5	116.7	25%	75%	24	15842
025U-100D	1003	3997	5000	11.3	111.1	20%	80%	25.4	21299
025U-125D	1005	4977	5981	14.2	105.7	17%	83%	26.5	26521
050U-050D	1975	2061	4035	8.2	123.8	49%	51%	20.7	10981
050U-075D	1966	2973	4938	10.4	119	40%	60%	22.8	15842
050U-100D	1957	3997	5954	13.1	113.6	33%	67%	24.4	21299
050U-125D	1950	4977	6926	16	108.2	28%	72%	25.6	26521
075U-050D	2990	2061	5051	10.3	122.9	59%	41%	19.7	10981
075U-075D	2977	2973	5949	12.5	119	50%	50%	21.9	15842
075U-100D	2963	3997	6960	15.2	114.3	43%	57%	23.6	21299
075U-125D	2953	4977	7929	18.1	109.4	37%	63%	24.8	26521
100U-050D	3963	2062	6025	12.6	119.5	66%	34%	18.9	10981
100U-075D	3945	2974	6919	14.8	116.7	57%	43%	21.2	15842
100U-100D	3928	3998	7925	17.6	112.9	50%	50%	23	21299
100U-125D	3914	4977	8891	20.5	108.7	44%	56%	24.2	26521
125U-050D	5015	2061	7077	15.4	114.7	71%	29%	18.2	10981
125U-075D	4993	2973	7966	17.7	112.8	63%	37%	20.6	15842
125U-100D	4970	3997	8967	20.4	110	55%	45%	22.4	21299
125U-125D	4953	4977	9930	23.3	106.7	50%	50%	23.7	26521
150U-050D	6005	2062	8067	18.6	108.4	74%	26%	17.7	10981
150U-075D	5985	2973	8958	20.8	107.5	67%	33%	20.1	15842
150U-100D	5946	3997	9943	23.6	105.6	60%	40%	21.9	21299
150U-125D	5895	4977	10872	26.5	102.8	54%	46%	23.3	26521



Notes:

- (1) UGR values per CIE 190:2010 with 4H, 8H, Reflectance: 70% Ceiling, 50% Wall, 20% Ref. Plane
- (2) For other UGR data for room or reflective ceiling plans please see technical data on website.
- (3) Luminance measured at 45-90 degrees from nadir.
- (4) UGR and Luminance values that meet WELL v2 L04 requirements for Managing Glare are shown with green highlighted cell. (UGR < 16, Luminance < 6,000, Indirect-only)
- (5) UGR and Luminance values that meet LEED v4.1 requirements for Glare Control are shown with green text. (UGR < 19, Luminance < 7,000, Indirect-only)
- (6) For technical data of other configurations please see photometric section on website or click link at top-right

KEY:

	Meets WELL v2
TEXT	Meets LEED v4.1

Lumen Adjustment Factors

CCT	3000K		3500K		4000K	
CRI	80+	90+	80+	90+	80+	90+
Lumen Multiplier	0.956	0.803	1.000	0.852	0.988	0.888
Melanopic Ratio	0.494	0.591	0.574	0.674	0.675	0.752

Example Calculation:

025U-075D / 3500K / 80 CRI  
Lumen Output selected = 985 lms/ft

3500K / 90 CRI Desired  
Lumen Adjustment Factor = 0.852

Adjusted Lumen Output = 985 lms/ft x 0.852 = 839 lms/ft





Energy and Performance Data - Frosted Lens Batwing (FB)

Continua SQ2 Suspended Performance (3500K)								Glare	
Lumen Package	Lumens/ft Up	Lumens/ft Down	Lumens/ft Total	W/ft Total	Lm/W	Distribution (up%)	Distribution (down%)	UGR (1-2)(4-6)	MAX LUMINANCE (3-6)
0U-050D	0	2055	2055	4.5	115.5	0%	100%	26.7	17781
0U-075D	0	2965	2965	6.7	111	0%	100%	28	25650
0U-100D	0	3986	3986	9.4	106	0%	100%	29	34487
0U-125D	0	4964	4964	12.3	100.9	0%	100%	29.8	42942
025U-050D	1011	2056	3067	6.3	121.7	33%	67%	24.2	17781
025U-075D	1006	2965	3971	8.5	116.5	25%	75%	26	25650
025U-100D	1003	3987	4990	11.3	110.9	20%	80%	27.5	34487
025U-125D	1005	4964	5969	14.2	105.5	17%	83%	28.5	42942
050U-050D	1975	2056	4030	8.2	123.6	49%	51%	22.8	17781
050U-075D	1966	2965	4931	10.4	118.8	40%	60%	24.9	25650
050U-100D	1957	3987	5944	13.1	113.4	33%	67%	26.5	34487
050U-125D	1950	4964	6914	16	108	28%	72%	27.6	42942
075U-050D	2990	2056	5046	10.3	122.8	59%	41%	21.7	17781
075U-075D	2977	2965	5942	12.5	118.8	50%	50%	23.9	25650
075U-100D	2963	3987	6950	15.2	114.1	43%	57%	25.6	34487
075U-125D	2953	4964	7917	18.1	109.2	37%	63%	26.9	42942
100U-050D	3963	2057	6020	12.6	119.4	66%	34%	21	17781
100U-075D	3945	2966	6911	14.8	116.6	57%	43%	23.2	25650
100U-100D	3928	3988	7915	17.6	112.8	50%	50%	25	34487
100U-125D	3914	4965	8879	20.5	108.5	44%	56%	26.3	42942
125U-050D	5015	2056	7072	15.4	114.6	71%	29%	20.3	17781
125U-075D	4993	2966	7959	17.7	112.7	63%	37%	22.6	25650
125U-100D	4970	3987	8957	20.4	109.9	55%	45%	24.4	34487
125U-125D	4953	4965	9918	23.3	106.5	50%	50%	25.7	42942
150U-050D	6005	2056	8061	18.6	108.4	74%	26%	19.7	17781
150U-075D	5985	2966	8951	20.8	107.5	67%	33%	22.1	25650
150U-100D	5946	3988	9933	23.6	105.5	60%	40%	24	34487
150U-125D	5895	4965	10860	26.5	102.6	54%	46%	25.3	42942



Notes:

- (1) UGR values per CIE 190:2010 with 4H, 8H, Reflectance: 70% Ceiling, 50% Wall, 20% Ref. Plane
- (2) For other UGR data for room or reflective ceiling plans please see technical data on website.
- (3) Luminance measured at 45-90 degrees from nadir.
- (4) UGR and Luminance values that meet WELL v2 L04 requirements for Managing Glare are shown with green highlighted cell. (UGR < 16, Luminance < 6,000, Indirect-only)
- (5) UGR and Luminance values that meet LEED v4.1 requirements for Glare Control are shown with green text. (UGR < 19, Luminance < 7,000, Indirect-only)
- (6) For technical data of other configurations please see photometric section on website or click link at top-right

KEY:

	Meets WELL v2
TEXT	Meets LEED v4.1

Lumen Adjustment Factors

CCT	3000K		3500K		4000K	
CRI	80+	90+	80+	90+	80+	90+
Lumen Multiplier	0.956	0.803	1.000	0.852	0.988	0.888
Melanopic Ratio	0.494	0.591	0.574	0.674	0.675	0.752

Example Calculation:

025U-075D / 3500K / 80 CRI  
Lumen Output selected = 985 lms/ft

3500K / 90 CRI Desired  
Lumen Adjustment Factor = 0.852

Adjusted Lumen Output = 985 lms/ft x 0.852 = 839 lms/ft



Energy and Performance Data - Frosted Lens Asymmetric (FA)

Continua SQ2 Suspended Performance (3500K)								Glare	
Lumen Package	Lumens/ft Up	Lumens/ft Down	Lumens/ft Total	W/ft Total	Lm/W	Distribution (up%)	Distribution (down%)	UGR (1-2)(4-6)	MAX LUMINANCE (3-6)
0U-050D	0	1936	1936	4.5	108.8	0%	100%	22.6	17856
0U-075D	0	2794	2794	6.7	104.6	0%	100%	23.8	25759
0U-100D	0	3756	3756	9.4	99.9	0%	100%	24.9	34632
0U-125D	0	4677	4677	12.3	95.1	0%	100%	25.6	43124
025U-050D	1011	1937	2948	6.3	117	34%	66%	19.8	17856
025U-075D	1006	2794	3799	8.5	111.4	26%	74%	21.7	25759
025U-100D	1003	3756	4759	11.3	105.8	21%	79%	23.2	34632
025U-125D	1005	4677	5682	14.2	100.4	18%	82%	24.2	43124
050U-050D	1975	1937	3912	8.2	120	50%	50%	18.3	17856
050U-075D	1966	2794	4759	10.4	114.7	41%	59%	20.5	25759
050U-100D	1957	3756	5713	13.1	109	34%	66%	22.1	34632
050U-125D	1950	4677	6627	16	103.5	29%	71%	23.3	43124
075U-050D	2990	1937	4927	10.3	119.9	61%	39%	17.2	17856
075U-075D	2977	2794	5771	12.5	115.4	52%	48%	19.5	25759
075U-100D	2963	3756	6720	15.2	110.3	44%	56%	21.2	34632
075U-125D	2953	4677	7630	18.1	105.2	39%	61%	22.5	43124
100U-050D	3963	1938	5901	12.6	117.1	67%	33%	16.5	17856
100U-075D	3945	2795	6740	14.8	113.7	59%	41%	18.8	25759
100U-100D	3928	3757	7685	17.6	109.5	51%	49%	20.6	34632
100U-125D	3914	4678	8592	20.5	105	46%	54%	21.9	43124
125U-050D	5015	1937	6953	15.4	112.7	72%	28%	15.8	17856
125U-075D	4993	2794	7787	17.7	110.3	64%	36%	18.1	25759
125U-100D	4970	3757	8727	20.4	107.1	57%	43%	20	34632
125U-125D	4953	4678	9631	23.3	103.4	51%	49%	21.3	43124
150U-050D	6005	1938	7943	18.6	106.8	76%	24%	15.2	17856
150U-075D	5985	2795	8779	20.8	105.4	68%	32%	17.6	25759
150U-100D	5946	3757	9703	23.6	103	61%	39%	19.5	34632
150U-125D	5895	4678	10573	26.5	99.9	56%	44%	20.9	43124



Notes:

- (1) UGR values per CIE 190:2010 with 4H, 8H, Reflectance: 70% Ceiling, 50% Wall, 20% Ref. Plane
- (2) For other UGR data for room or reflective ceiling plans please see technical data on website.
- (3) Luminance measured at 45-90 degrees from nadir.
- (4) UGR and Luminance values that meet WELL v2 L04 requirements for Managing Glare are shown with green highlighted cell. (UGR < 16, Luminance < 6,000, Indirect-only)
- (5) UGR and Luminance values that meet LEED v4.1 requirements for Glare Control are shown with green text. (UGR < 19, Luminance < 7,000, Indirect-only)
- (6) For technical data of other configurations please see photometric section on website or click link at top-right

KEY:

	Meets WELL v2
TEXT	Meets LEED v4.1

Lumen Adjustment Factors

CCT	3000K		3500K		4000K	
CRI	80+	90+	80+	90+	80+	90+
Lumen Multiplier	0.956	0.803	1.000	0.852	0.988	0.888
Melanopic Ratio	0.494	0.591	0.574	0.674	0.675	0.752

Example Calculation:

025U-075D / 3500K / 80 CRI  
Lumen Output selected = 985 lms/ft

3500K / 90 CRI Desired  
Lumen Adjustment Factor = 0.852

Adjusted Lumen Output = 985 lms/ft x 0.852 = 839 lms/ft



Energy and Performance Data - Perceive™ Lenses

Glare								
Lumen Package	Honeycomb (PH1)		Prism (PP3)		Waves (PW1)		Ripple (PR1)	
	UGR (1-2)(4-6)	MAX LUMINANCE (3-6)	UGR (1-2)(4-6)	MAX LUMINANCE (3-6)	UGR (1-2)(4-6)	MAX LUMINANCE (3-6)	UGR (1-2)(4-6)	MAX LUMINANCE (3-6)
0U-050D	25.1	15413	23.4	15253	23.5	15573	23.2	15502
0U-075D	26.4	22233	24.7	22003	24.8	22464	24.5	22361
0U-100D	27.4	29894	25.7	29583	25.8	30204	25.5	30065
0U-125D	28.2	37223	26.5	36838	26.6	37609	26.2	37434
025U-050D	22.8	15413	21	15253	21.1	15573	20.8	15502
025U-075D	24.6	22233	22.9	22003	23	22464	22.7	22361
025U-100D	26	29894	24.3	29583	24.4	30204	24.1	30065
025U-125D	27	37223	25.3	36838	25.4	37609	25.1	37434
050U-050D	21.5	15413	19.7	15253	19.8	15573	19.5	15502
050U-075D	23.5	22233	21.8	22003	21.8	22464	21.5	22361
050U-100D	25.1	29894	23.3	29583	23.4	30204	23.1	30065
050U-125D	26.2	37223	24.5	36838	24.5	37609	24.2	37434
075U-050D	20.4	15413	18.7	15253	18.7	15573	18.5	15502
075U-075D	22.6	22233	20.9	22003	20.9	22464	20.6	22361
075U-100D	24.3	29894	22.6	29583	22.6	30204	22.3	30065
075U-125D	25.5	37223	23.8	36838	23.8	37609	23.5	37434
100U-050D	19.7	15413	18	15253	18	15573	17.7	15502
100U-075D	21.9	22233	20.2	22003	20.2	22464	20	22361
100U-100D	23.7	29894	22	29583	22	30204	21.7	30065
100U-125D	24.9	37223	23.2	36838	23.3	37609	23	37434
125U-050D	19	15413	17.3	15253	17.3	15573	17	15502
125U-075D	21.3	22233	19.6	22003	19.6	22464	19.3	22361
125U-100D	23.1	29894	21.4	29583	21.4	30204	21.1	30065
125U-125D	24.4	37223	22.7	36838	22.7	37609	22.4	37434
150U-050D	18.5	15413	16.8	15253	16.8	15573	16.5	15502
150U-075D	20.8	22233	19.1	22003	19.1	22464	18.8	22361
150U-100D	22.7	29894	20.9	29583	21	30204	20.7	30065
150U-125D	24	37223	22.3	36838	22.3	37609	22	37434



Notes:

- (1) UGR values per CIE 190:2010 with 4H, 8H, Reflectance: 70% Ceiling, 50% Wall, 20% Ref. Plane
- (2) For other UGR data for room or reflective ceiling plans please see technical data on website.
- (3) Luminance measured at 45-90 degrees from nadir.
- (4) UGR and Luminance values that meet WELL v2 L04 requirements for Managing Glare are shown with green highlighted cell. (UGR < 16, Luminance < 6,000, Indirect-only)
- (5) UGR and Luminance values that meet LEED v4.1 requirements for Glare Control are shown with green text. (UGR < 19, Luminance < 7,000, Indirect-only)
- (6) For technical data of other configurations please see photometric section on website or click link at top-right

KEY:

	Meets WELL v2
TEXT	Meets LEED v4.1

Lumen Adjustment Factors

CCT	3000K		3500K		4000K	
CRI	80+	90+	80+	90+	80+	90+
Lumen Multiplier	0.956	0.803	1.000	0.852	0.988	0.888
Melanopic Ratio	0.494	0.591	0.574	0.674	0.675	0.752

Example Calculation:

025U-075D / 3500K / 80 CRI  
Lumen Output selected = 985 lms/ft

3500K / 90 CRI/ Perceive Prism Lens Desired

Lumen Adjustment Factor = 0.852  
Lens Lumen Adjustment Factor (Direct Output) = 0.970

Adjusted Lumen Output:

Lumens Up = 242 lms/ft x 0.852 = 206 lms/ft  
Lumens Down = 744 lms/ft x 0.852 x 0.970 = 615 lms/ft  
Total Lumens = 206 lms/ft + 615 lms/ft = 821 lms/ft

Lens Lumen Multipliers (applied to Direct/Down output)- Perceive Lenses	
F = Frosted	1.000
PP3 = Perceive Prism	0.970
PW1 = Perceive Waves	0.964
PR1 = Perceive Ripple	0.959



Energy and Performance Data - White Baffle (SQ2-WBM)

Continua SQ2 Suspended Performance (3500K)								Glare	
Lumen Package	Lumens/ft Up	Lumens/ft Down	Lumens/ft Total	W/ft Total	Lm/W	Distribution (up%)	Distribution (down%)	UGR <sup>(1-2)(4-6)</sup>	MAX LUMINANCE <sup>(3-6)</sup>
0U-050D	0	2192	2192	4.5	121.1	0%	100%	9.2	11485
0U-075D	0	3263	3263	6.9	118.2	0%	100%	10.6	17102
0U-100D	0	4360	4360	9.5	114.4	0%	100%	11.6	23007
0U-125D	0	5446	5446	12.4	109.6	0%	100%	12.4	28496
025U-050D	1011	2193	3204	6.4	125.7	32%	68%	6.6	11485
025U-075D	1006	3265	4271	8.8	122	24%	76%	8.6	17112
025U-100D	1003	4360	5363	11.4	117.9	19%	81%	10	23003
025U-125D	1005	5440	6444	14.3	112.9	16%	84%	11.1	28458
050U-050D	1975	2193	4167	8.2	126.7	47%	53%	5.2	11485
050U-075D	1966	3265	5231	10.6	123.4	38%	62%	7.4	17112
050U-100D	1957	4360	6317	13.2	119.4	31%	69%	9	23003
050U-125D	1950	5440	7389	16.1	114.6	26%	74%	10.2	28458
075U-050D	2990	2193	5183	10.4	125.2	58%	42%	4.1	11485
075U-075D	2977	3265	6242	12.7	122.6	48%	52%	6.5	17112
075U-100D	2963	4360	7323	15.4	119.3	40%	60%	8.2	23003
075U-125D	2953	5440	8392	18.3	115	35%	65%	9.4	28458
100U-050D	3963	2194	6157	12.7	121.4	64%	36%	3.3	11485
100U-075D	3945	3266	7211	15.1	119.8	55%	45%	5.8	17112
100U-100D	3928	4361	8288	17.7	117.2	47%	53%	7.5	23003
100U-125D	3914	5440	9354	20.6	113.7	42%	58%	8.8	28458
125U-050D	5015	2193	7209	15.5	116.3	70%	30%	2.6	11485
125U-075D	4993	3266	8258	17.9	115.5	60%	40%	5.2	17112
125U-100D	4970	4361	9331	20.5	113.8	53%	47%	6.9	23003
125U-125D	4953	5440	10393	23.4	111	48%	52%	8.3	28458
150U-050D	6005	2194	8199	18.7	109.8	73%	27%	2.1	11485
150U-075D	5985	3266	9251	21.1	109.9	65%	35%	4.7	17112
150U-100D	5946	4361	10307	23.7	108.8	58%	42%	6.5	23003
150U-125D	5895	5440	11335	26.6	106.6	52%	48%	7.9	28458



Notes:

- (1) UGR values per CIE 190:2010 with 4H, 8H, Reflectance: 70% Ceiling, 50% Wall, 20% Ref. Plane
- (2) For other UGR data for room or reflective ceiling plans please see technical data on website.
- (3) Luminance measured at 45-90 degrees from nadir.
- (4) UGR and Luminance values that meet WELL v2 L04 requirements for Managing Glare are shown with green highlighted cell. (UGR < 16, Luminance < 6,000, Indirect-only)
- (5) UGR and Luminance values that meet LEED v4.1 requirements for Glare Control are shown with green text. (UGR < 19, Luminance < 7,000, Indirect-only)
- (6) For technical data of other configurations please see photometric section on website or click link at top-right

KEY:

	Meets WELL v2
TEXT	Meets LEED v4.1

Lumen Adjustment Factors

CCT	3000K		3500K		4000K	
	80+	90+	80+	90+	80+	90+
CRI						
Lumen Multiplier	0.956	0.803	1.000	0.852	0.988	0.888
Melanopic Ratio	0.494	0.591	0.574	0.674	0.675	0.752

Example Calculation:

025U-075D / 3500K / 80 CRI  
Lumen Output selected = 985 lms/ft

3500K / 90 CRI Desired  
Lumen Adjustment Factor = 0.852

Adjusted Lumen Output = 985 lms/ft x 0.852 = 839 lms/ft



Energy and Performance Data - White Baffle (SQ2-WBN)

Continua SQ2 Suspended Performance (3500K)								Glare	
Lumen Package	Lumens/ft Up	Lumens/ft Down	Lumens/ft Total	W/ft Total	Lm/W	Distribution (up%)	Distribution (down%)	UGR <sup>(1-2)(4-6)</sup>	MAX LUMINANCE <sup>(3-6)</sup>
0U-050D	0	2201	2201	4.5	121.6	0%	100%	8	6309
0U-075D	0	3276	3276	6.9	118.7	0%	100%	9.3	9391
0U-100D	0	4377	4377	9.5	114.9	0%	100%	10.3	12547
0U-125D	0	5478	5478	12.4	110.2	0%	100%	11.1	15705
025U-050D	1011	2202	3213	6.4	126	31%	69%	5.3	6311
025U-075D	1006	3281	4287	8.8	122.5	23%	77%	7.4	9407
025U-100D	1003	4397	5400	11.4	118.7	19%	81%	8.8	12604
025U-125D	1005	5425	6429	14.3	112.6	16%	84%	9.8	15552
050U-050D	1975	2201	4176	8.2	126.9	47%	53%	3.9	6311
050U-075D	1966	3278	5244	10.6	123.7	37%	63%	6.2	9396
050U-100D	1957	4377	6334	13.2	119.7	31%	69%	7.7	12547
050U-125D	1950	5460	7410	16.1	114.9	26%	74%	8.9	15655
075U-050D	2990	2202	5192	10.4	125.4	58%	42%	2.8	6311
075U-075D	2977	3278	6255	12.7	122.9	48%	52%	5.2	9398
075U-100D	2963	4377	7340	15.4	119.6	40%	60%	6.9	12549
075U-125D	2953	5461	8414	18.3	115.3	35%	65%	8.2	15655
100U-050D	3963	2203	6166	12.7	121.6	64%	36%	2	6314
100U-075D	3945	3280	7225	15.1	120	55%	45%	4.5	9401
100U-100D	3928	4379	8307	17.7	117.5	47%	53%	6.3	12552
100U-125D	3914	5463	9377	20.6	113.9	42%	58%	7.6	15659
125U-050D	5015	2202	7218	15.5	116.4	69%	31%	1.4	6311
125U-075D	4993	3279	8272	17.9	115.7	60%	40%	3.9	9398
125U-100D	4970	4378	9348	20.5	114	53%	47%	5.7	12549
125U-125D	4953	5462	10415	23.4	111.3	48%	52%	7	15657
150U-050D	6005	2202	8207	18.7	109.9	73%	27%	0.8	6311
150U-075D	5985	3279	9264	21.1	110	65%	35%	3.4	9398
150U-100D	5946	4357	10303	23.7	108.8	58%	42%	5.2	12490
150U-125D	5895	5472	11367	26.6	106.9	52%	48%	6.6	15687



Notes:

- (1) UGR values per CIE 190:2010 with 4H, 8H, Reflectance: 70% Ceiling, 50% Wall, 20% Ref. Plane
- (2) For other UGR data for room or reflective ceiling plans please see technical data on website.
- (3) Luminance measured at 45-90 degrees from nadir.
- (4) UGR and Luminance values that meet WELL v2 L04 requirements for Managing Glare are shown with green highlighted cell. (UGR < 16, Luminance < 6,000, Indirect-only)
- (5) UGR and Luminance values that meet LEED v4.1 requirements for Glare Control are shown with green text. (UGR < 19, Luminance < 7,000, Indirect-only)
- (6) For technical data of other configurations please see photometric section on website or click link at top-right

KEY:

	Meets WELL v2
TEXT	Meets LEED v4.1

Lumen Adjustment Factors

CCT	3000K		3500K		4000K	
	80+	90+	80+	90+	80+	90+
CRI						
Lumen Multiplier	0.956	0.803	1.000	0.852	0.988	0.888
Melanopic Ratio	0.494	0.591	0.574	0.674	0.675	0.752

Example Calculation:

025U-075D / 3500K / 80 CRI  
Lumen Output selected = 985 lms/ft

3500K / 90 CRI Desired  
Lumen Adjustment Factor = 0.852

Adjusted Lumen Output = 985 lms/ft x 0.852 = 839 lms/ft



Energy and Performance Data - Black Baffle (SQ2-BBM)

Continua SQ2 Suspended Performance (3500K)								Glare	
Lumen Package	Lumens/ft Up	Lumens/ft Down	Lumens/ft Total	W/ft Total	Lm/W	Distribution (up%)	Distribution (down%)	UGR <sup>(1-2)(4-6)</sup>	MAX LUMINANCE <sup>(3-6)</sup>
0U-050D	0	2008	2008	4.5	110.9	0%	100%	0	10458
0U-075D	0	2988	2988	6.9	108.3	0%	100%	1.4	15710
0U-100D	0	3993	3993	9.5	104.8	0%	100%	2.3	20710
0U-125D	0	4997	4997	12.5	100.3	0%	100%	3.1	26119
025U-050D	1011	2009	3020	6.4	118.4	33%	67%	0	10460
025U-075D	1006	2994	3999	8.8	114.3	25%	75%	0	15737
025U-100D	1003	4011	5014	11.4	110	20%	80%	0.6	20801
025U-125D	1005	4949	5953	14.3	104.1	17%	83%	1.7	25866
050U-050D	1975	2009	3983	8.2	121.1	50%	50%	0	10458
050U-075D	1966	2990	4956	10.6	116.9	40%	60%	0	15719
050U-100D	1957	3993	5950	13.2	112.5	33%	67%	0	20710
050U-125D	1950	4981	6931	16.2	107.3	28%	72%	0.7	26035
075U-050D	2990	2009	4999	10.4	120.7	60%	40%	0	10460
075U-075D	2977	2991	5967	12.7	117.2	50%	50%	0	15721
075U-100D	2963	3994	6957	15.4	113.3	43%	57%	0	20710
075U-125D	2953	4982	7935	18.3	108.5	37%	63%	0	26037
100U-050D	3963	2010	5974	12.7	117.8	66%	34%	0	10462
100U-075D	3945	2993	6938	15.1	115.2	57%	43%	0	15726
100U-100D	3928	3996	7923	17.7	112.1	50%	50%	0	20717
100U-125D	3914	4985	8898	20.6	108	44%	56%	0	26046
125U-050D	5015	2010	7025	15.5	113.3	71%	29%	0	10460
125U-075D	4993	2992	7984	17.9	111.7	63%	37%	0	15723
125U-100D	4970	3995	8965	20.5	109.3	55%	45%	0	20712
125U-125D	4953	4983	9936	23.4	106	50%	50%	0	26042
150U-050D	6005	2010	8015	18.7	107.3	75%	25%	0	10460
150U-075D	5985	2992	8976	21	106.7	67%	33%	0	15721
150U-100D	5946	3976	9921	23.6	105.2	60%	40%	0	20612
150U-125D	5895	4993	10887	26.5	102.8	54%	46%	0	26090



Notes:

- (1) UGR values per CIE 190:2010 with 4H, 8H, Reflectance: 70% Ceiling, 50% Wall, 20% Ref. Plane
- (2) For other UGR data for room or reflective ceiling plans please see technical data on website.
- (3) Luminance measured at 45-90 degrees from nadir.
- (4) UGR and Luminance values that meet WELL v2 L04 requirements for Managing Glare are shown with green highlighted cell. (UGR < 16, Luminance < 6,000, Indirect-only)
- (5) UGR and Luminance values that meet LEED v4.1 requirements for Glare Control are shown with green text. (UGR < 19, Luminance < 7,000, Indirect-only)
- (6) For technical data of other configurations please see photometric section on website or click link at top-right

KEY:

	Meets WELL v2
TEXT	Meets LEED v4.1

Lumen Adjustment Factors

CCT	3000K		3500K		4000K	
CRI	80+	90+	80+	90+	80+	90+
Lumen Multiplier	0.956	0.803	1.000	0.852	0.988	0.888
Melanopic Ratio	0.494	0.591	0.574	0.674	0.675	0.752

Example Calculation:

025U-075D / 3500K / 80 CRI  
Lumen Output selected = 985 lms/ft

3500K / 90 CRI Desired  
Lumen Adjustment Factor = 0.852

Adjusted Lumen Output = 985 lms/ft x 0.852 = 839 lms/ft



**Energy and Performance Data - Black Baffle (SQ2-BBN)**

Continua SQ2 Suspended Performance (3500K)								Glare	
Lumen Package	Lumens/ft Up	Lumens/ft Down	Lumens/ft Total	W/ft Total	Lm/W	Distribution (up%)	Distribution (down%)	UGR <sup>(1-2)(4-6)</sup>	MAX LUMINANCE <sup>(3-6)</sup>
0U-050D	0	2017	2017	4.5	111.4	0%	100%	0	5327
0U-075D	0	3002	3002	6.9	108.8	0%	100%	0	7930
0U-100D	0	4011	4011	9.5	105.3	0%	100%	0	10595
0U-125D	0	5020	5020	12.5	100.8	0%	100%	0	13260
025U-050D	1011	2018	3029	6.4	118.8	33%	67%	0	5329
025U-075D	1006	3007	4013	8.8	114.7	25%	75%	0	7944
025U-100D	1003	4029	5032	11.4	110.4	20%	80%	0	10643
025U-125D	1005	4971	5976	14.3	104.5	17%	83%	0	13132
050U-050D	1975	2018	3992	8.2	121.3	49%	51%	0	5327
050U-075D	1966	3004	4970	10.6	117.2	40%	60%	0	7935
050U-100D	1957	4011	5968	13.2	112.8	33%	67%	0	10595
050U-125D	1950	5004	6954	16.2	107.6	28%	72%	0	13216
075U-050D	2990	2018	5008	10.4	121	60%	40%	0	5329
075U-075D	2977	3005	5981	12.7	117.5	50%	50%	0	7935
075U-100D	2963	4012	6974	15.4	113.6	42%	58%	0	10595
075U-125D	2953	5005	7957	18.3	108.9	37%	63%	0	13218
100U-050D	3963	2019	5982	12.7	118	66%	34%	0	5329
100U-075D	3945	3006	6951	15.1	115.5	57%	43%	0	7937
100U-100D	3928	4014	7941	17.7	112.3	49%	51%	0	10599
100U-125D	3914	5007	8921	20.6	108.3	44%	56%	0	13223
125U-050D	5015	2019	7034	15.5	113.4	71%	29%	0	5329
125U-075D	4993	3005	7998	17.9	111.9	62%	38%	0	7935
125U-100D	4970	4012	8982	20.5	109.5	55%	45%	0	10597
125U-125D	4953	5006	9958	23.4	106.3	50%	50%	0	13218
150U-050D	6005	2019	8023	18.7	107.4	75%	25%	0	5329
150U-075D	5985	3006	8990	21	106.9	67%	33%	0	7935
150U-100D	5946	3993	9939	23.6	105.4	60%	40%	0	10545
150U-125D	5895	5015	10910	26.5	103	54%	46%	0	13244



**Notes:**

- (1) UGR values per CIE 190:2010 with 4H, 8H, Reflectance: 70% Ceiling, 50% Wall, 20% Ref. Plane
- (2) For other UGR data for room or reflective ceiling plans please see technical data on website.
- (3) Luminance measured at 45-90 degrees from nadir.
- (4) UGR and Luminance values that meet WELL v2 L04 requirements for Managing Glare are shown with green highlighted cell. (UGR < 16, Luminance < 6,000, Indirect-only)
- (5) UGR and Luminance values that meet LEED v4.1 requirements for Glare Control are shown with green text. (UGR < 19, Luminance < 7,000, Indirect-only)
- (6) For technical data of other configurations please see photometric section on website or click link at top-right

**KEY:**

	Meets WELL v2
TEXT	Meets LEED v4.1

**Lumen Adjustment Factors**

CCT	3000K		3500K		4000K	
CRI	80+	90+	80+	90+	80+	90+
Lumen Multiplier	0.956	0.803	1.000	0.852	0.988	0.888
Melanopic Ratio	0.494	0.591	0.574	0.674	0.675	0.752

**Example Calculation:**

025U-075D / 3500K / 80 CRI  
Lumen Output selected = 985 lms/ft

3500K / 90 CRI Desired  
Lumen Adjustment Factor = 0.852

Adjusted Lumen Output = 985 lms/ft x 0.852 = 839 lms/ft



**Control Solutions**

- WaveLinx LITE wireless
- WaveLinx PRO wireless
- WaveLinx CAT wired
- WaveLinx Wired



The SQ2 with WaveLinx offers no-hassle lighting control with multiple luminaire level control solutions.



**WaveLinx PRO** is a wireless lighting control solution, for connected spaces, that significantly reduces a building's energy consumption. From a single floor to an entire campus, WaveLinx PRO connects more than lighting assets; it shares aggregated sensor data with the WaveLinx CORE platform and other building systems, so building owners can improve operations, spaces environment, and tenants' experience. WaveLinx PRO offers a rich portfolio of wireless devices, WaveLinx PRO-enabled luminaires, and an intuitive WaveLinx mobile app for office, education, warehouse, and parking garage applications.



**WaveLinx LITE** is a cost effective, wireless digital lighting control solution, with out-of-the-box functionality, that saves energy and meets code. It's designed for applications that require occupancy-based, daylighting, or manual light control. Customize installations for office, education, warehouse and parking garages using the secure, simple mobile app.

**Integrated Sensor Coverage Pattern**

TOP VIEW:

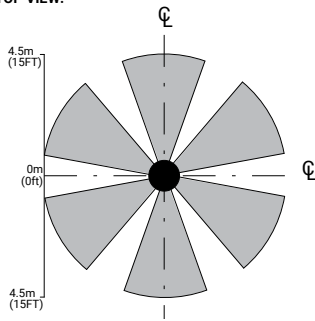

SIDE VIEW:

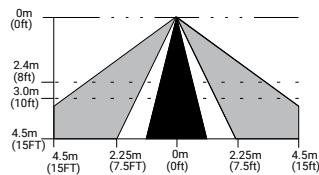

**Note:** Installation of integrated sensors within 3-ft (1m) of HVAC air vents is not recommended. The pattern shown is intended solely as a general guide and is not to scale.



SQ2 Suspended with Integrated Sensor - Endcap



SQ2 Suspended with Integrated Sensor - Side Mount

Add a hidden WaveLinx sensor node (WPN, WLN) to your space lighting design!

**Allows to:**

- Keeps luminaire aesthetics
- Connect fixtures without the realestate to include sensor option such as downlights
- Connect sealed fixtures without a standard sensor option such as products for clinical space.

**Integrated Controls Options**

Option	Out of the Box Functionality	Luminaire Level Lighting Control (LLC)	Automatic Dimming Photocell	Occupancy Sensing
WLS	X	X	X	X
WLN		X		
WPS		X	X	X
WPN		X		

**Systems comparison chart**

Cooper Lighting Solutions provides many lighting system solutions designed to satisfy code requirements and meet the unique needs of any project.



**Luminaire with standalone sensor**

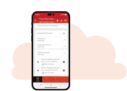

**Standalone Spaces WaveLinx LITE**



**Standalone Spaces WaveLinx CAT**



**Networked Spaces WaveLinx PRO**



**Enterprise WaveLinx CORE**

	Luminaire with standalone sensor	Standalone Spaces WaveLinx LITE	Standalone Spaces WaveLinx CAT	Networked Spaces WaveLinx PRO	Enterprise WaveLinx CORE
<b>Occupancy</b>	Yes	Yes	Yes	Yes	Yes
<b>Daylighting</b>	Yes	Yes	Yes	Yes	Yes
<b>Wallstations</b>	-	Yes	Yes	Yes	Yes
<b>Gateways</b>	-	-	-	1 WAC	300 WACs
<b>Devices (MAX)</b>	-	40 per Area (1120 per space)	40 per Area	200 per WAC2	32,500 per CORE Enterprise
<b>Software</b>	-	WaveLinx LITE Mobile App	WaveLinx CAT Mobile App	WaveLinx Mobile App	CORE
<b>Areas</b>	-	28 per Space	Unlimited	50 per WAC2	up to 3,000
<b>Zones</b>	-	16 per Area	16 per Area	16 per Area	up to 9,000
<b>Scheduling</b>	-	-	-	Local	Global
<b>VividTune™</b>	-	-	-	Yes	Yes
<b>Plug-Load Control</b>	-	Yes	Yes	Yes	Yes
<b>Low-Voltage Power</b>	-	-	Yes	Yes	Yes
<b>Integration</b>	-	-	-	-	BACnet, API
<b>Dashboards</b>	-	-	-	-	Energy, Occupancy
<b>Configuration</b>	-	Installer	Installer	Technician	Technician / IT





Default Integral Sensor Placement

Sensor Type	Wireless	Sensor Integration	Sensor Mounting	Ordering Code
WaveLinX	Yes	Integral to Fixture or Tile Mount	Mounted in solid cover	WAA/WAB

- Standard Sensor with Luminaire Control
- Auxiliary Sensor used for Sensor Coverage (wireless systems only)
- Sidecar mount sensors

CONTINUOUS ROLL LENS / PERCIEVE SENSOR LAYOUT EXAMPLES

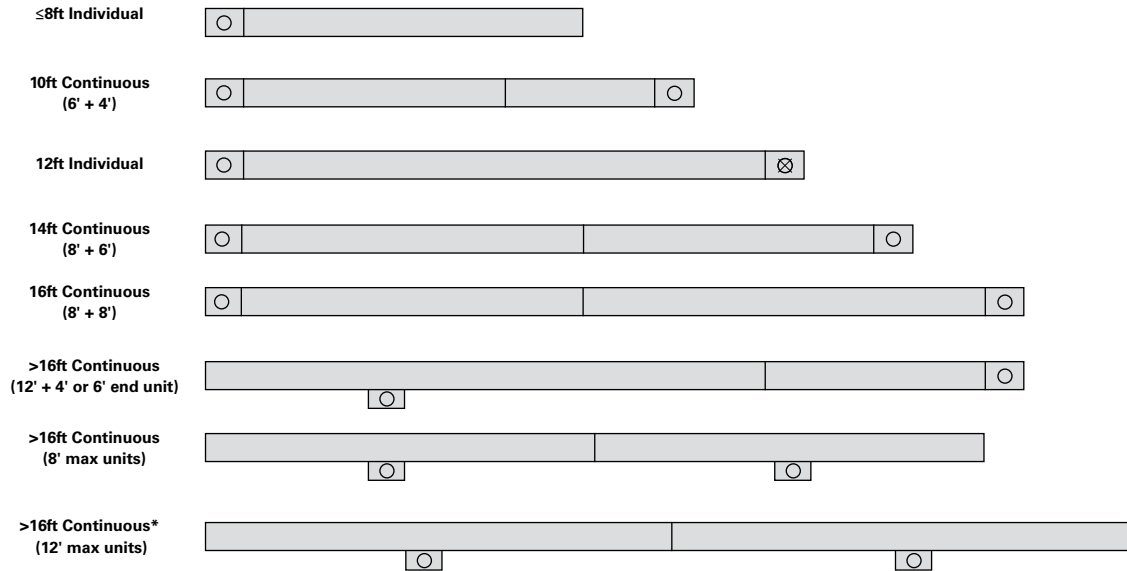

DISCREET OPTICS SENSOR LAYOUT EXAMPLES

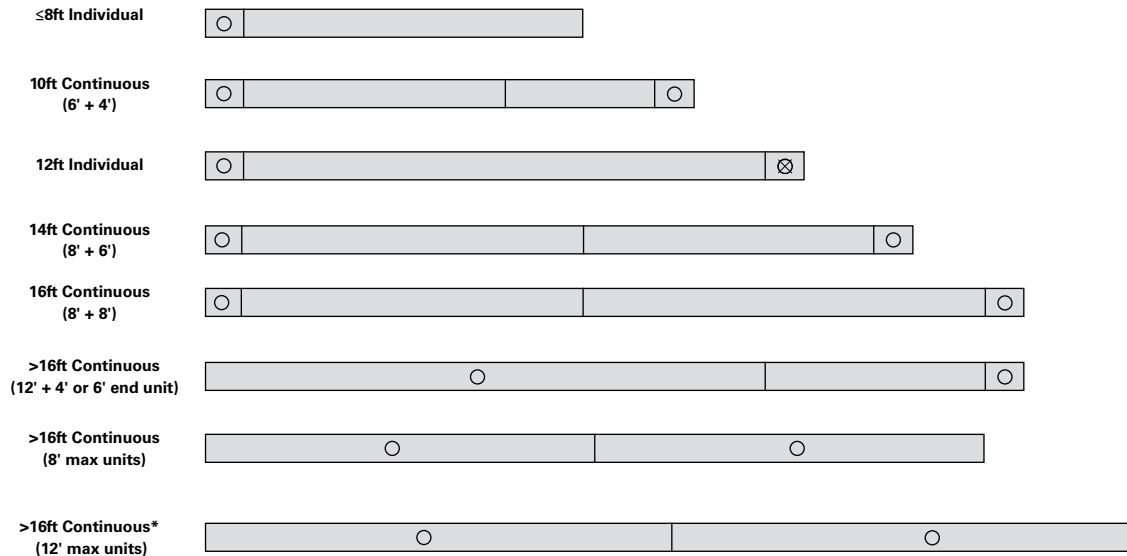

Note: \*See Standard Row Configuration table on Page 14.  
 8' sensor spacing for continuous runs using 8' max units.  
 4' and 6' units at the ends of runs will utilize sensor end caps.



Battery Integration

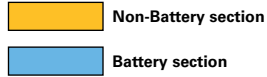

Discreet Baffles

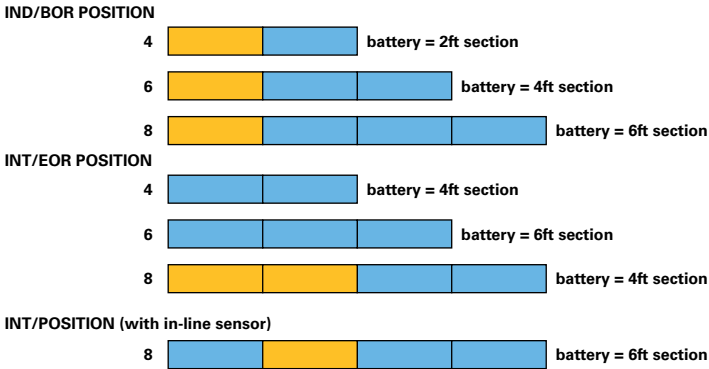

Continuous Lens

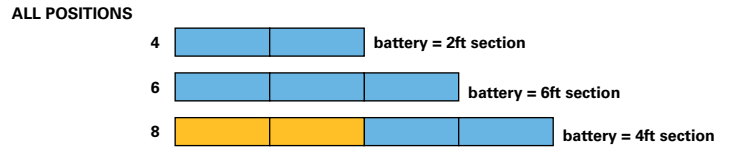

Standard Row Configurations

Fixture Length	2'	4'	6'	8'	10'	12'	14'	16'	18'	20'	22'	24'	26'	28'	30'	32'	34'	36'	38'	40'	42'	44'	46'	48'	50'	
2'	1																									
4'		1			1																					
6'			1		1		1		1		1		1		1		1		1		1		1		1	
8'				1			1	2		1	2		1	2		1	2		1	2		1	2		1	
12'						1			1	1		2	1	1	2	2	1	3	2	2	3	3	2	4	3	

Fixture Length	52'	54'	56'	58'	60'	62'	64'	66'	68'	70'	72'	74'	76'	78'	80'	82'	84'	86'	88'	90'	92'	94'	96'	98'	100'	
4'																										
6'		1		1		1		1		1		1		1		1		1		1		1		1		1
8'	2		1	2		1	2		1	2		1	2		1	2		1	2		1	2		1	2	
12'	3	4	4	3	5	4	4	5	5	4	6	5	5	6	6	5	7	6	6	7	7	6	8	7	7	



**Driver Availability - Discreet Baffles**

Lumen Package	'STD' 0-10V, UNV Qty of Drivers					'5LT' DALI / 'SR' Qty of Drivers					'L5'/'LH' Qty of Drivers					'STD' 0-10V, 347V Qty of Drivers				
	2'	4'	6'	8'	12'	2'	4'	6'	8'	12'	2'	4'	6'	8'	12'	2'	4'	6'	8'	12'
0U-050D	1	1	1	1	1	N/A	1	1	1	1	N/A	1	1	1	1	N/A	1	1	1	1
0U-075D	1	1	1	1	2	N/A	1	1	1	2	N/A	1	1	1	2	N/A	1	1	1	2
0U-100D	1	1	1	1	2	N/A	1	1	1	2	N/A	1	1	1	2	N/A	1	1	1	2
0U-125D	1	1	1	2	2	N/A	1	1	2	2	N/A	1	1	2	2	N/A	1	1	2	2
025U-050D	N/A	2	2	2	2	N/A	2	2	2	2	N/A	2	2	2	2	N/A	2	2	2	2
025U-075D	N/A	2	2	2	3	N/A	2	2	2	3	N/A	2	2	2	3	N/A	2	2	2	3
025U-100D	N/A	2	2	2	3	N/A	2	2	2	3	N/A	2	2	2	3	N/A	2	2	2	3
025U-125D	N/A	2	2	3	3	N/A	2	2	3	3	N/A	2	2	3	3	N/A	2	2	3	3
050U-050D	2	2	2	2	2	N/A	2	2	2	2	N/A	2	2	2	2	N/A	2	2	2	2
050U-075D	2	2	2	2	3	N/A	2	2	2	3	N/A	2	2	2	3	N/A	2	2	2	3
050U-100D	2	2	2	2	3	N/A	2	2	2	3	N/A	2	2	2	3	N/A	2	2	2	3
050U-125D	2	2	2	3	3	N/A	2	2	3	3	N/A	2	2	3	3	N/A	2	2	3	3
075U-050D	2	2	2	2	2	N/A	2	2	2	2	N/A	2	2	2	2	N/A	2	2	2	2
075U-075D	2	2	2	2	3	N/A	2	2	2	3	N/A	2	2	2	3	N/A	2	2	2	3
075U-100D	2	2	2	2	3	N/A	2	2	2	3	N/A	2	2	2	3	N/A	2	2	2	3
075U-125D	2	2	2	3	3	N/A	2	2	3	3	N/A	2	2	3	3	N/A	2	2	3	3
100U-050D	2	2	2	2	3	N/A	2	2	2	3	N/A	2	2	2	3	N/A	2	2	2	3
100U-075D	2	2	2	2	4	N/A	2	2	2	4	N/A	2	2	2	4	N/A	2	2	2	4
100U-100D	2	2	2	2	4	N/A	2	2	2	4	N/A	2	2	2	4	N/A	2	2	2	4
100U-125D	2	2	2	3	4	N/A	2	2	3	4	N/A	2	2	3	4	N/A	2	2	3	4
125U-050D	2	2	2	3	3	N/A	2	2	3	3	N/A	2	2	3	3	N/A	2	2	3	3
125U-075D	2	2	2	3	4	N/A	2	2	3	4	N/A	2	2	3	4	N/A	2	2	3	4
125U-100D	2	2	2	3	4	N/A	2	2	3	4	N/A	2	2	3	4	N/A	2	2	3	4
125U-125D	2	2	2	4	4	N/A	2	2	4	4	N/A	2	2	4	4	N/A	2	2	4	4
150U-050D	N/A	2	2	3	3	N/A	2	2	3	3	N/A	2	2	3	3	N/A	2	2	3	3
150U-075D	N/A	2	2	3	4	N/A	2	2	3	4	N/A	2	2	3	4	N/A	2	2	3	4
150U-100D	N/A	2	2	3	4	N/A	2	2	3	4	N/A	2	2	3	4	N/A	2	2	3	4
150U-125D	N/A	2	2	4	4	N/A	2	2	4	4	N/A	2	2	4	4	N/A	2	2	4	4



Driver Availability - Frosted Lens

Lumen Package	'STD' 0-10V, UNV					'5LT' DALI / 'SR'					'L5'/'LH'					'STD' 0-10V, 347V				
	2'	4'	6'	8'	12'	2'	4'	6'	8'	12'	2'	4'	6'	8'	12'	2'	4'	6'	8'	12'
0U-050D	1	1	1	1	1	N/A	1	1	1	1	N/A	1	1	1	1	N/A	1	1	1	1
0U-075D	1	1	1	1	1	N/A	1	1	1	1	N/A	1	1	1	1	N/A	1	1	1	1
0U-100D	1	1	1	1	2	N/A	1	1	1	2	N/A	1	1	1	2	N/A	1	1	1	2
0U-125D	1	1	1	1	2	N/A	1	1	1	2	N/A	1	1	1	2	N/A	1	1	1	2
025U-050D	N/A	2	2	2	2	N/A	2	2	2	2	N/A	2	2	2	2	N/A	2	2	2	2
025U-075D	N/A	2	2	2	2	N/A	2	2	2	2	N/A	2	2	2	2	N/A	2	2	2	2
025U-100D	N/A	2	2	2	3	N/A	2	2	2	3	N/A	2	2	2	3	N/A	2	2	2	3
025U-125D	N/A	2	2	2	3	N/A	2	2	2	3	N/A	2	2	2	3	N/A	2	2	2	3
050U-050D	2	2	2	2	2	N/A	2	2	2	2	N/A	2	2	2	2	N/A	2	2	2	2
050U-075D	2	2	2	2	2	N/A	2	2	2	2	N/A	2	2	2	2	N/A	2	2	2	2
050U-100D	2	2	2	2	3	N/A	2	2	2	3	N/A	2	2	2	3	N/A	2	2	2	3
050U-125D	2	2	2	2	3	N/A	2	2	2	3	N/A	2	2	2	3	N/A	2	2	2	3
075U-050D	2	2	2	2	2	N/A	2	2	2	2	N/A	2	2	2	2	N/A	2	2	2	2
075U-075D	2	2	2	2	2	N/A	2	2	2	2	N/A	2	2	2	2	N/A	2	2	2	2
075U-100D	2	2	2	2	3	N/A	2	2	2	3	N/A	2	2	2	3	N/A	2	2	2	3
075U-125D	2	2	2	2	3	N/A	2	2	2	3	N/A	2	2	2	3	N/A	2	2	2	3
100U-050D	2	2	2	2	3	N/A	2	2	2	3	N/A	2	2	2	3	N/A	2	2	2	3
100U-075D	2	2	2	2	3	N/A	2	2	2	3	N/A	2	2	2	3	N/A	2	2	2	3
100U-100D	2	2	2	2	4	N/A	2	2	2	4	N/A	2	2	2	4	N/A	2	2	2	4
100U-125D	2	2	2	2	4	N/A	2	2	2	4	N/A	2	2	2	4	N/A	2	2	2	4
125U-050D	2	2	2	2	3	N/A	2	2	2	3	N/A	2	2	2	3	N/A	2	2	2	3
125U-075D	2	2	2	2	3	N/A	2	2	2	3	N/A	2	2	2	3	N/A	2	2	2	3
125U-100D	2	2	2	2	4	N/A	2	2	2	4	N/A	2	2	2	4	N/A	2	2	2	4
125U-125D	2	2	2	2	4	N/A	2	2	2	4	N/A	2	2	2	4	N/A	2	2	2	4
150U-050D	N/A	2	2	3	3	N/A	2	2	3	3	N/A	2	2	3	3	N/A	2	2	3	3
150U-075D	N/A	2	2	3	3	N/A	2	2	3	3	N/A	2	2	3	3	N/A	2	2	3	3
150U-100D	N/A	2	2	3	4	N/A	2	2	3	4	N/A	2	2	3	4	N/A	2	2	3	4
150U-125D	N/A	2	2	3	4	N/A	2	2	3	4	N/A	2	2	3	4	N/A	2	2	3	4

