

Installation Instructions – 401, 403, 405, 407, 409, 411, 413, 415, 417

Instructions d'installation – 401, 403, 405, 407, 409, 411, 413, 415, 417

Instrucciones de instalación – 401, 403, 405, 407, 409, 411, 413, 415, 417

IMPORTANT: Read carefully before installing fixture. Failure to comply with these instructions may result in death, serious bodily injury and property damage. Retain for future reference.

WARNING



Risk of Fire, Electrical Shock, Cuts or other Casualty Hazards- Installation and maintenance of this product must be performed by a qualified electrician. This product must be installed in accordance with the applicable installation code by a person familiar with the construction and operation of the product and hazards involved.



Risk of Fire and Electric Shock- Make certain power is OFF before starting installation or attempting any maintenance. Disconnect power at fuse or circuit breaker.



Risk of Fire- Minimum 90°C supply conductors.



Risk of Burn- Disconnect power and allow fixture to cool before handling or servicing.



- These instructions do not claim to cover all details or variations in the equipment, procedure, or process described, nor to provide directions for meeting every possible contingency during installation, operation or maintenance. When additional information is desired to satisfy a problem not covered sufficiently for user's purpose, please contact your nearest representative.
- This lighting fixture has been shipped complete with one of several mounting options. Please follow the installation instructions specific to the catalog part that you ordered.



Risk of Personal Injury or property damage- Fixture may become damaged and/or unstable if not installed properly.

- Do not install this product in locations such as gymnasiums, arenas, sports complexes, multi-purpose rooms, and other locations where the fixture potentially will be subject to impacts from external sources. Doing so may result in cracking and/or breaking of the fixture which may cause pieces to fall from application.
- Clean with a dry cloth only. Do not apply abrasive chemicals or cleaning agents. Doing so may result in cracking and/or breaking of the fixture which may cause pieces to fall from application.
- Do not install this product in food prep areas and hazardous environments which may expose the product to pollutants such as oil, grease, or VOC's. Doing so will void the products warranty.
- Do not mount luminaire within 6" of a combustible surface.
- Specifications and dimensions subject to change without notice.
- Ensure adequate structure to support luminaire weight.

DISCLAIMER OF LIABILITY: Cooper Lighting Solutions assumes no liability for damages or losses of any kind that may arise from the improper, careless, or negligent installation, handling or use of this product.

NOTICE: Fixture may become damaged and/or unstable if not installed properly.

Note: Specifications and dimensions subject to change without notice.

ATTENTION Receiving Department: Note actual fixture description of any shortage or noticeable damage on delivery receipt. File claim for common carrier (LTL) directly with carrier. Claims for concealed damage must be filed within 15 days of delivery. All damaged material, complete with original packing must be retained.

Installation Instructions – 400's Series Lamp Based Canopy Assembly

401

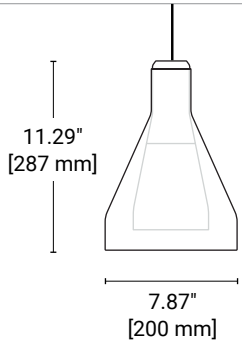

403

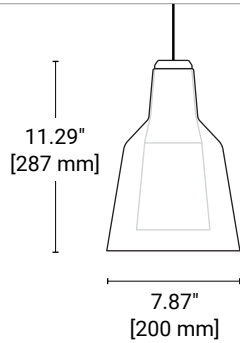

405

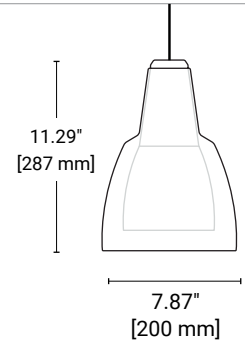

407

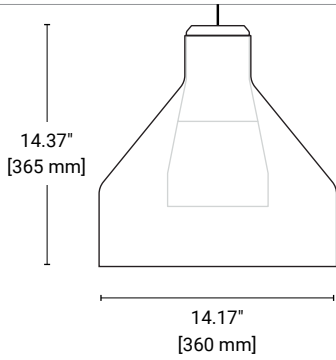

409

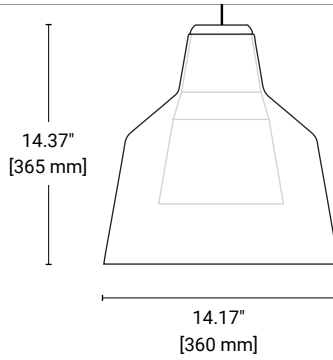

411

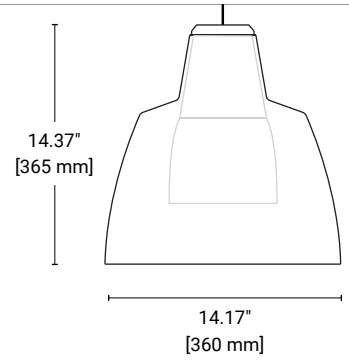

413

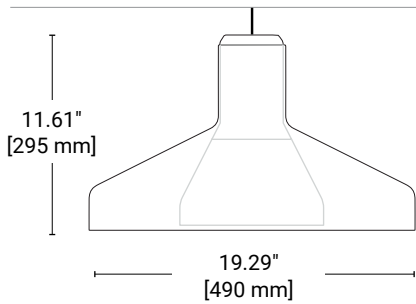

415

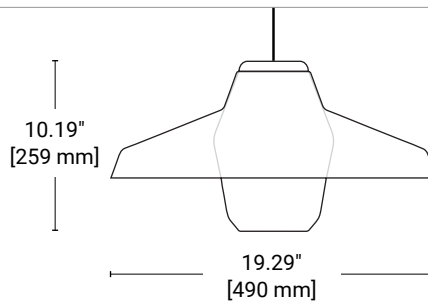

417

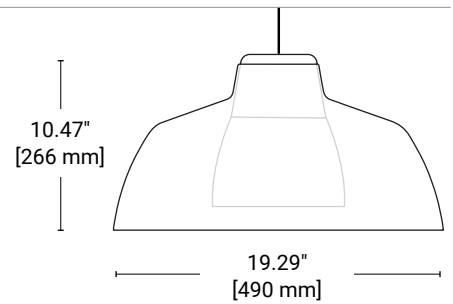

Installation Instructions – 400's Series Lamp Based Canopy Assembly

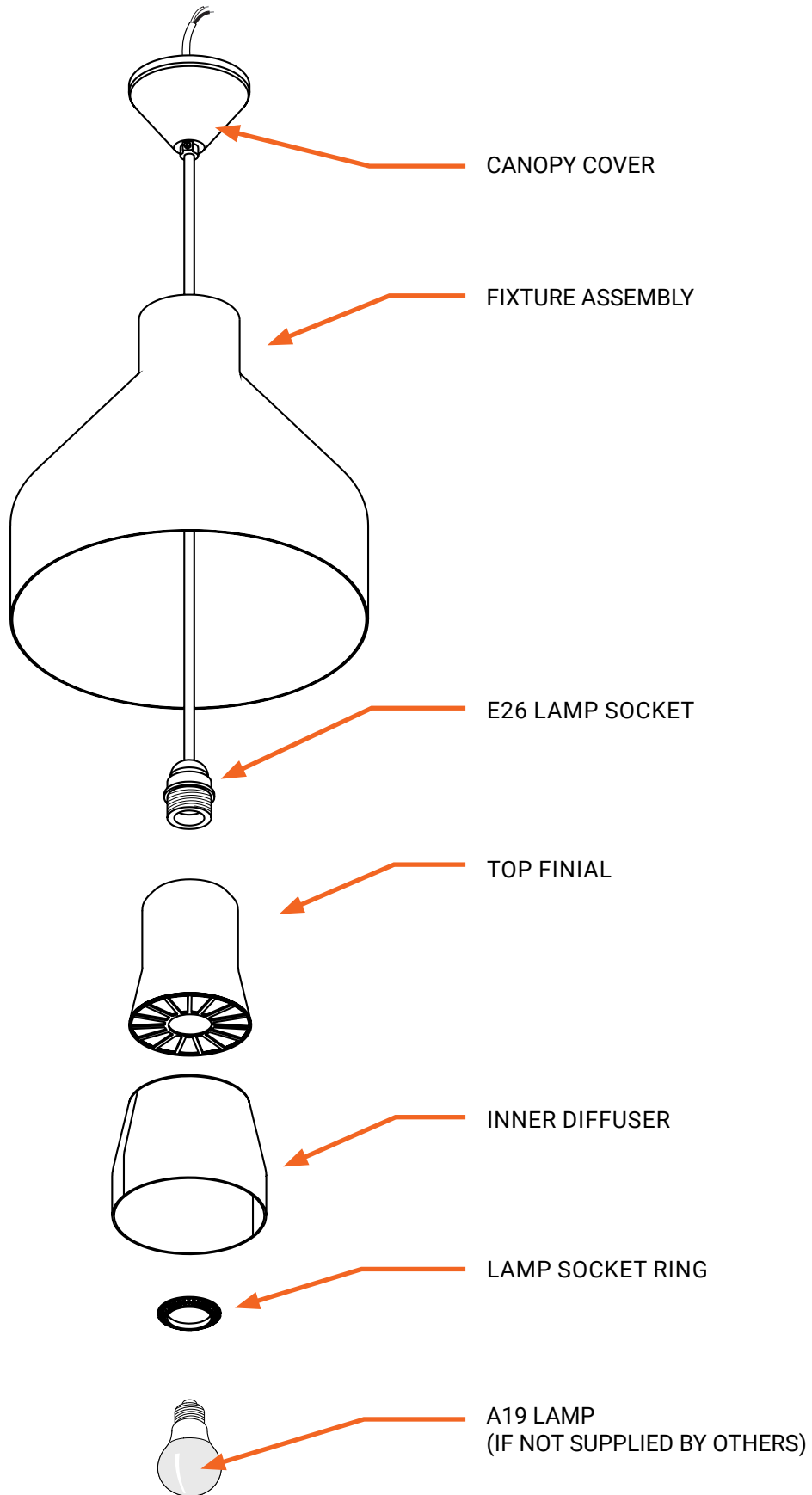

Installation Instructions – 400's Series Lamp Based Canopy Assembly

Figure 1 Components Exploded View

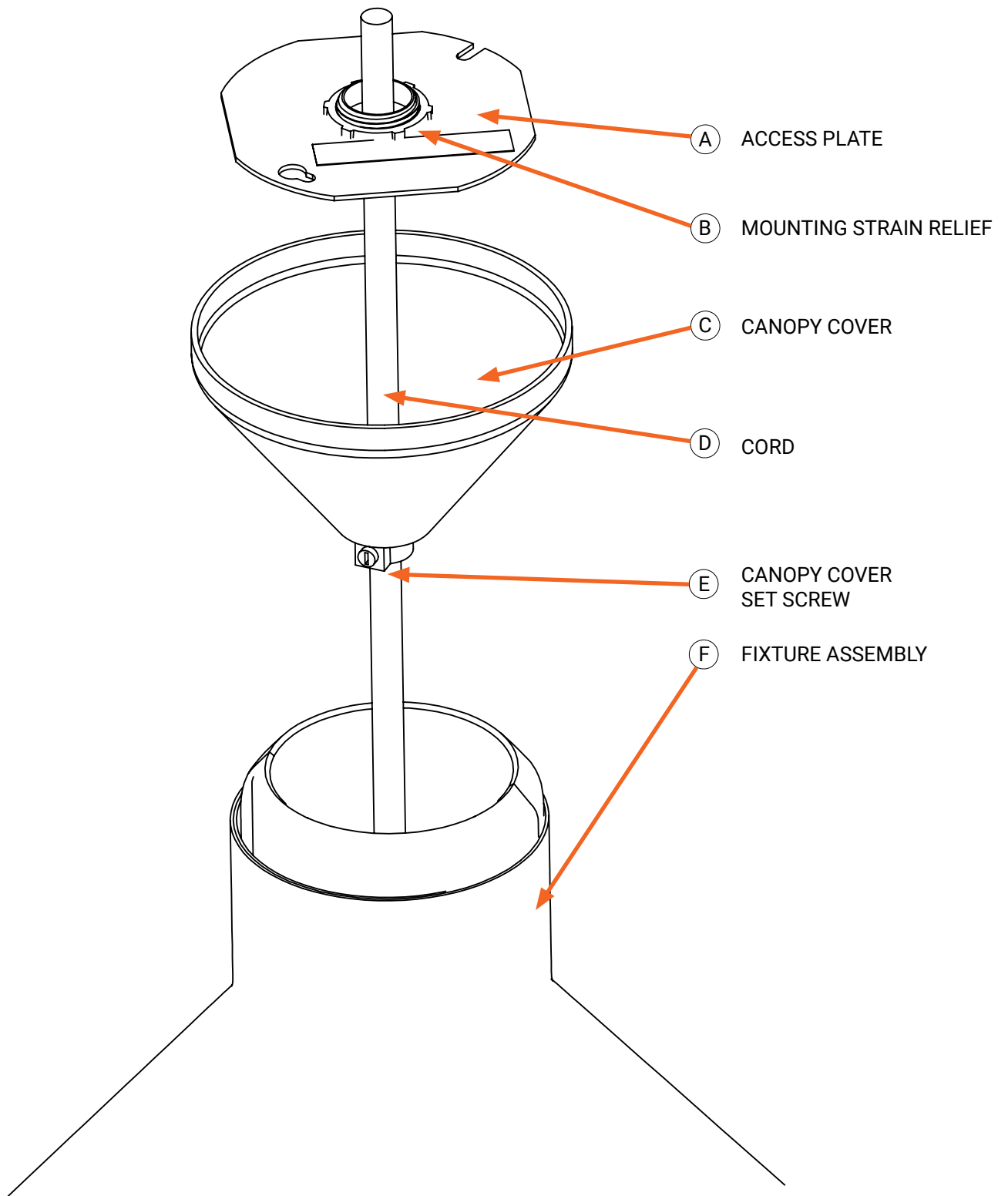

Installation Instructions – 400's Series Lamp Based Canopy Assembly

Figure 2

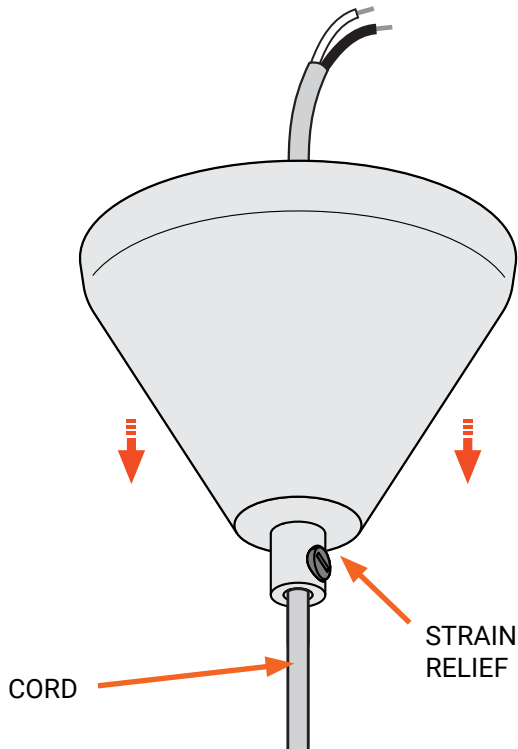

1. Ensure power is off at junction box.
2. Carefully remove lighting fixture, hardware, cords, and packaging from box. Inspect to ensure all items Fig 1. are included.
3. Pre-determine desired overall mounting height of **Fixture (F)** and **Cord (D)**. Trim excess cord while leaving 3-6 inches of whip/ exposed **Cord (D)** for making wiring connections inside the junction box.
4. Slide the **Canopy Cover (C)** over the mounting **Cord (D)**. Leave plenty of extra cord slack. (Figure 2)

Figure 3

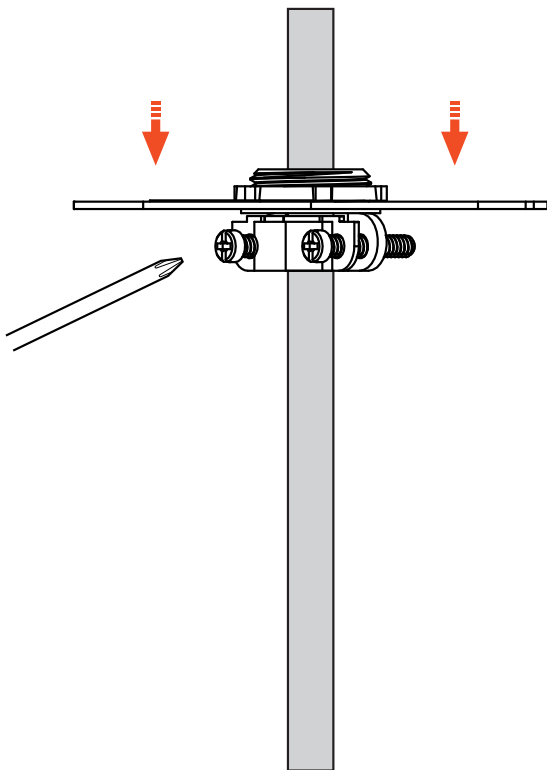

5. Remove the **Access Plate (A)** from the junction box cover provided and install the **Strain Relief (B)**, also provided, on to the plate. Ensure that it is tight.
6. Slide the **Access Plate (A)** over the wire and tighten the, qty 2, #8 Philips screws on the **Strain Relief (B)** to secure. Carefully ensure the strain relief makes contact with the outer jacket of the wire and is adequately tight. (Figure 3)

Installation Instructions – 400's Series Lamp Based Canopy Assembly

Figure 4

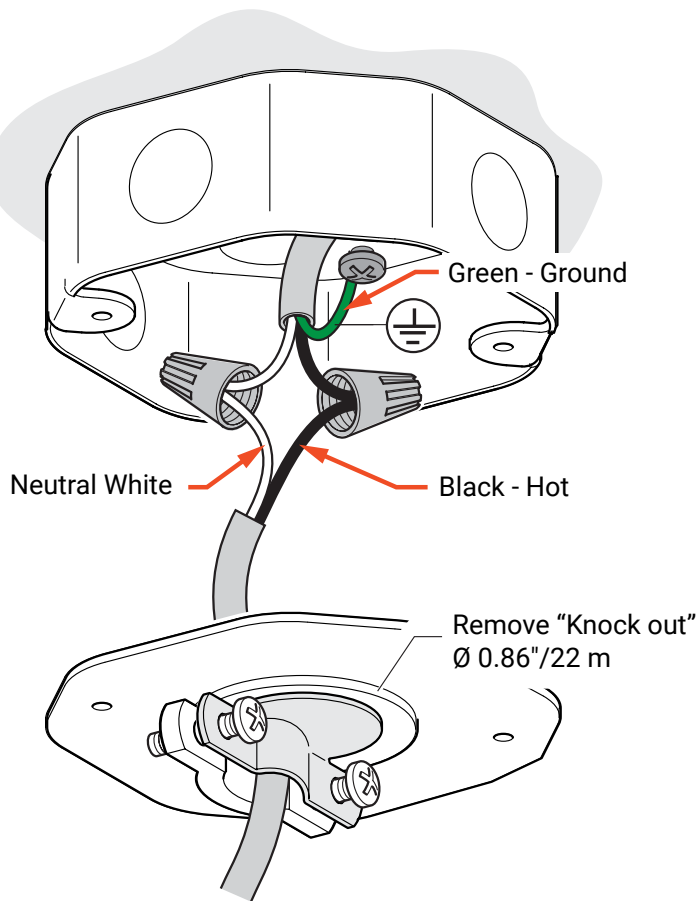

7. Complete wiring per included wiring diagram. (Figure 4)



Power Supply (Input)	
	Black (BK) - Hot
	White (WT) - Neutral
	Green (GN) - Ground

Figure 5



8. Attach **Access Plate (A)** and assembly to the junction box (not shown) ensuring that the fixture is at the correct mounting height and that the 2 screws (not included) are adequately tight. (Figure 5)

Installation Instructions – 400's Series Lamp Based Canopy Assembly

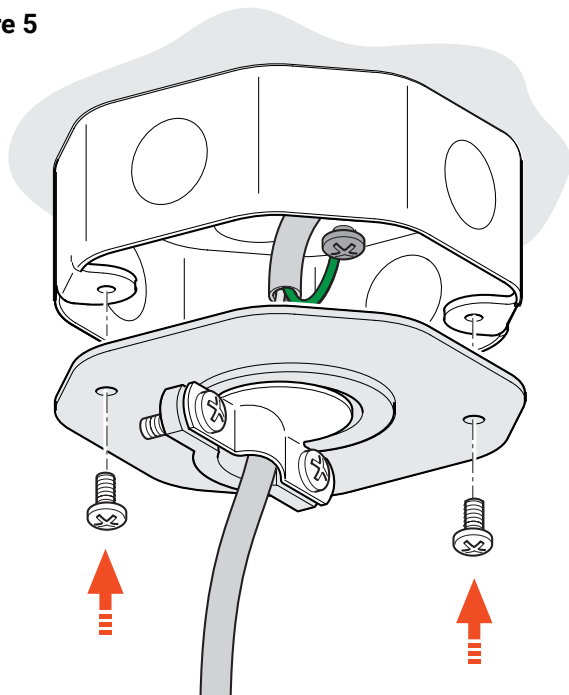
Figure 6

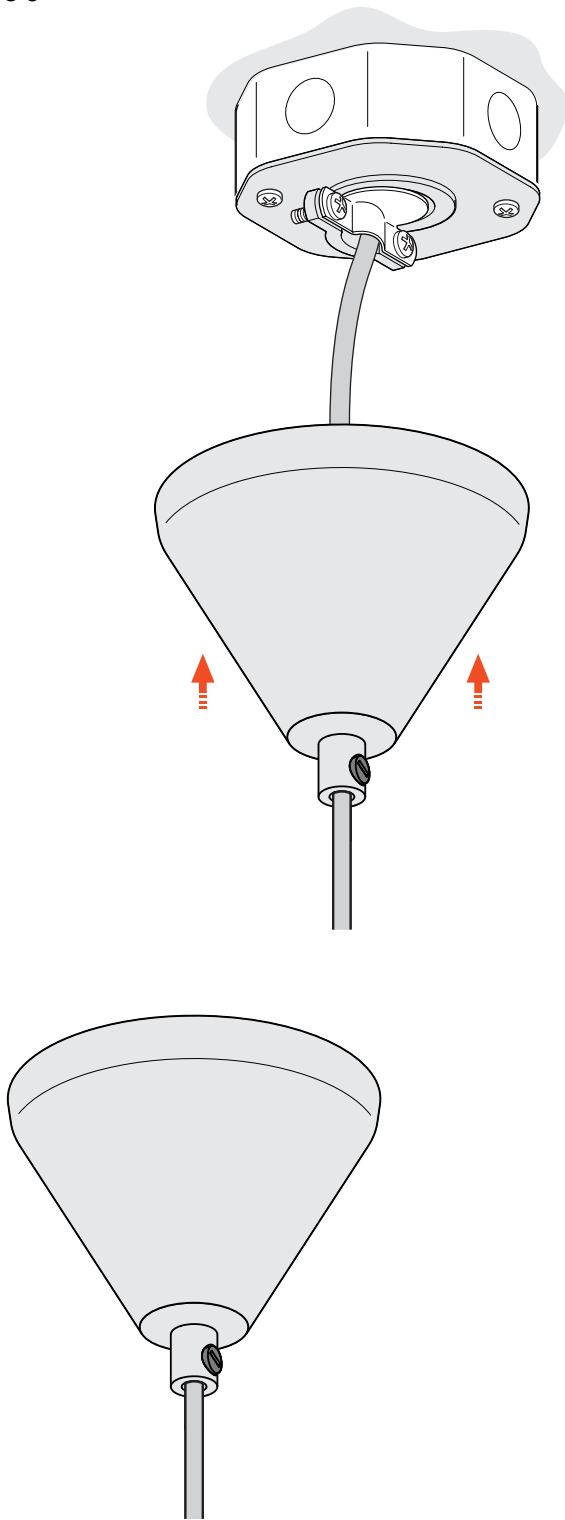

9. Raise the **Canopy Cover (C)** upward until the canopy cover is secured flush against the junction box or ceiling. Tighten **Canopy Cover Set Screw (E)** to secure. (Figure 6)

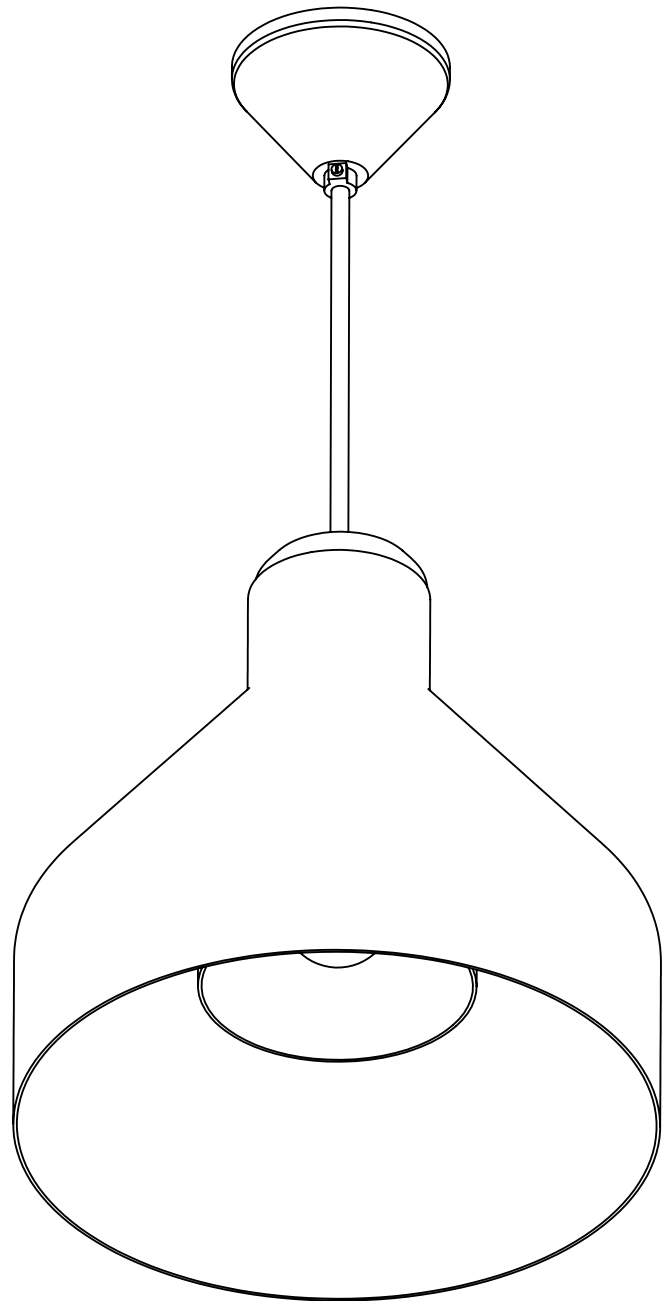

FCC Statement

Note: This equipment has been tested and found to comply with the limits for a Class A digital device, pursuant to part 15 of the FCC Rules. These limits are designed to provide reasonable protection against harmful interference when the equipment is operated in a commercial environment. This equipment generates, uses, and can radiate radio frequency energy and, if not installed and used in accordance with the instruction manual, may cause harmful interference to radio communications. Operation of this equipment in a residential area is likely to cause harmful interference in which case the user will be required to correct the interference at his own expense.

Énoncé de la FCC

Remarque : Cet équipement a été mis à l'essai et déclaré conforme aux limites établies pour un dispositif numérique de classe A en vertu de l'article 15 des règlements de la FCC. Ces limites sont conçues pour assurer une protection raisonnable contre tout brouillage nuisible lorsque l'équipement fonctionne dans un environnement commercial. Cet équipement produit, utilise et peut émettre de l'énergie radioélectrique et, s'il n'est pas installé et utilisé conformément aux instructions, il peut créer des parasites nuisibles aux communications radio. L'utilisation de cet équipement dans une installation résidentielle est susceptible de provoquer des interférences nuisibles, auquel cas l'utilisateur devra corriger ces interférences à ses propres frais.

Declaración de la FCC

Nota: Este equipo ha sido probado y cumple con los límites para un dispositivo digital de Clase A, de conformidad con la parte 15 de las Normas de la FCC. Estos límites están diseñados para proporcionar una protección razonable contra interferencias perjudiciales cuando el equipo se opera en un entorno comercial. Este equipo genera, utiliza y puede emitir energía de radiofrecuencia y, si no se instala y utiliza de acuerdo con el manual de instrucciones, puede causar interferencias perjudiciales en las comunicaciones de radio. El funcionamiento de este equipo en un área residencial puede causar interferencias perjudiciales, en cuyo caso el usuario deberá corregir las interferencias por su cuenta.

Warranties and Limitation of Liability

Please refer to www.cooperlighting.com/global/warranty for our terms and conditions.

Garanties et limitation de responsabilité

Veuillez consulter le site www.cooperlighting.com/global/warranty pour obtenir les conditions générales.

Garantías y Limitación de Responsabilidad

Visite www.cooperlighting.com/global/warranty para conocer nuestros términos y condiciones.

Cooper Lighting Solutions
1121 Highway 74 South
Peachtree City, GA 30269
P: 770-486-4800
www.cooperlighting.com

Canada Sales
5925 McLaughlin Road
Mississauga, Ontario L5R 1B8
P: 905-501-3000
F: 905-501-3172

© 2021 Cooper Lighting Solutions
All Rights Reserved
Publication No. SAMPLE#
January 12, 2023

Cooper Lighting Solutions is a registered trademark. All trademarks are property of their respective owners.

Cooper Lighting Solutions est une marque de commerce déposée. Toutes les autres marques de commerce sont la propriété de leur propriétaire respectif.

Cooper Lighting Solutions es una marca comercial registrada. Todas las marcas comerciales son propiedad de sus respectivos propietarios.

Product availability, specifications, and compliances are subject to change without notice

La disponibilité du produit, les spécifications et les conformités peuvent être modifiées sans préavis

La disponibilidad de productos, las especificaciones y los cumplimientos están sujetos a cambio sin previo aviso