



# LUMASPORT 16

White LED Sports Luminaire

## Installation Manual



### ASSEMBLE: EPH-LS-16-1200L Light Head ONLY WITH PART: EPH-LS-16-1200L Driver Box

**THIS PRODUCT MUST BE INSTALLED IN ACCORDANCE WITH THE APPLICABLE INSTALLATION CODE BY A PERSON FAMILIAR WITH THE CONSTRUCTION AND OPERATION OF THE PRODUCT AND THE HAZARDS INVOLVED**

**CE PRODUIT DOIT ÊTRE INSTALLÉ SELON LE CODE D'INSTALLATION PERTINENT, PAR UNE PERSONNE QUI CONNAÎT BIEN LE PRODUIT ET SON FONCTIONNEMENT AINSI QUE LES RISQUES INHÉRENTS**



## WARNINGS AND CAUTIONS

Follow all warnings and cautions outlined here as well as any local safety procedures. Failure to strictly adhere to the warnings and cautions as well as the installation instructions may result in serious personal injury or property damage

### Before You Begin

Read and understand this entire manual and any additional site-specific installation documents before attempting to assemble, install, or operate the luminaire. If you have any questions regarding the product or installation, contact Cooper Lighting Customer Service at 1-800-573-3600.

1. All electrical work must conform to National Electrical Code (NFPA 70), IEEE Emerald book, and all applicable local codes and ordinances.
2. Verify the capacity and integrity of existing power distribution system and correct branch circuit voltage before beginning installation.
3. Verify the structural capacity and safety of all facility/venue/pole supports and mounting apparatus before installation. See fixture specification sheet for weight and wind loading data.
4. Verify that the capacity and integrity of all existing mounting structures and electrical distribution systems are compatible with the new lighting system and compliant with all regulatory and safety codes.
5. In harsh settings where the system is subjected to factors such as extreme temperatures, high corrosion, hurricanes, or lightning, always follow local codes and additional protocols to ensure the cabling and other system components can withstand the environmental stress for the life of the system.
6. DO NOT make or alter any open holes in the luminaire. Do not modify the luminaire, internal wiring, or fixture mounting features. Opening or modifying the luminaire or bracket will void the warranty.
7. Use Personal Protective Equipment including hardhats, safety glasses, reflective vests, electrical safety gloves, fall protection equipment, and safety toe boots during installation, operation, and maintenance of luminaire.
8. Verify compliance with local standards to prevent access to the area below where installation activities are occurring to prevent injury from accidental drops of fixtures, tools or hardware.

### Storage

Store luminaires in a clean, dry place, protected from dirt, water, and sunlight prior to installation. See Table 1 for required storage and operating conditions:



EEL-UNV-0711

Storage Temperature	Operating Temperature	Humidity
-40°C to +75°C (-40°F to 167°F)	-40°C to +40°C (-40°F to 104°F)	5% to 95% non-condensing

Table 1. Storage and Operating Conditions



**Risk of Fire, Electrical Shock, Cuts or other Casualty Hazards** - Installation and maintenance of this product must be performed by a qualified electrician. This product must be installed in accordance with the applicable installation code by a person familiar with the construction and operation of the product and hazards involved.



**Risk of Fire and Electric Shock** - Make certain power is OFF before starting installation or attempting any maintenance. Disconnect power at fuse or circuit breaker.



**Risk of Fire** - Refer to product label for specific minimum supply conductor requirements.



**Risk of Burn** - Disconnect power and allow fixture to cool before handling or servicing.



**Risk of Personal Injury** - Fixture may become damaged and/or unstable if not installed properly.

**DISCLAIMER OF LIABILITY:** Cooper Lighting Solutions assumes no liability for damages or losses of any kind that may arise from the improper, careless, or negligent installation, handling or use of this product.

**NOTICE:** Green ground wire provided in proper location. Do not relocate.

**ATTENTION Receiving Department:** Note actual fixture description of any shortage or noticeable damage on delivery receipt. File claim for common carrier (LTL) directly with carrier. Claims for concealed damage must be filed within 15 days of delivery. All damaged material; complete with original packing must be retained.

**APPLICATIONS:** This lighting fixture should not be used in area of limited ventilation or inside high ambient temperature enclosures. It must be stored in a dry location before installation. Do not expose lighting fixture to rain, dust or other environmental conditions prior to installation. Best results will be obtained if installed and maintained according to the following recommendations.



**Required Tools and Materials**

- 3/16in Hex driver
- 9/16in Socket w/ driver
- 15/16in Socket w/ driver
- Deep well socket wrenches for LS8 and LS16 manuals
- 27mm cord grip tool (24mm if wired controlled)
- Ephesus Laser Aiming Kit (if applicable)



**Power Supply**

Cooper Lighting Ephesus LED luminaires are not traditional metal halide lights; they are high-tech, new-generation solid-state devices. To protect your valuable investment, ensure the electrical power supply is clean and stable with no spikes or sags.

The power transformer feeding the site electrical distribution system must be a three-phase, four-wire wye configuration or a single-phase configuration. An ungrounded delta configuration is **NOT** an approved power supply. If any other supply transformer configuration is present, notify Cooper Lighting before proceeding with installation.

All issues with supply power must be corrected before luminaires are installed. Failure to use an approved power supply configuration may result in equipment damage.



**Power Quality**

Follow proper grounding methods. The electrical system must be properly grounded for power electronics in accordance with IEEE Emerald Book, including using equipment grounding conductors. Metallic conduits are **NOT** an acceptable grounding method for Cooper Lighting LED lighting systems. Power must also be phase balanced. If you are not sure if your power system is grounded or load balanced, **DO NOT** install the luminaire and contact a licensed electrician for information on proper grounding and balancing methods as required by the National Electrical Code and IEEE standards.



**Surge Protection**

Installation of surge protection is recommended in power distribution systems that feed LED sports lighting. Failure to protect electrical circuits from surges may result in damage to fixtures.



**Branch Circuits**

Branch power circuits feeding luminaires shall have a measured voltage of within 4% of nominal voltage with no sags, swells, or transients.



**Voltage Configuration**

Before installing luminaires, verify that the fixture model number has the correct voltage configuration for your application. See fixture specification sheet for acceptable branch circuit voltage. Failure to confirm proper configuration may result in injury damage to fixtures.

LUMASPORT 16 SPECIFICATION SHEET URL:

<https://www.cooperlighting.com/content/dam/cooper-lighting/brands/ephesus/spec-sheets/ephesus-lumasport-16-specsheet.pdf>



**WARNING**

Failure to confirm proper configuration may result in injury or fixture damage.

When circuiting power to luminaires, load balance all circuits. See fixture specification sheet for power characteristic data.

**Electrical Performance Specifications**

**Technical Data**

Product	Input Voltage Range (VAC)	Nominal Input Power (W)	Input Current (A)	Power Factor (>60% Load)	THD (>60% Load)	Inrush (A <sup>2</sup> s)	Inrush period (ms)	Peak Inrush (A)
LS-16-1200	208-277	1290 (1393 Max)	4.7 - 6.2 (6.2 Max)	> 0.9	< 20%	4.9	7.64	128
	347-480	1290 (1350 Max)	2.8 - 3.7 (4.7 Max)	> 0.9	< 20%	40.8	1.74	360

**Note:** Measured at 25°C Ambient Conditions Operating Conditions and Clearances

### Operating Conditions and Clearances

Refer to the following sections for thermal, optical, and mechanical clearance requirements.

#### Thermal Clearances - Safe Operation

Installer shall verify there are adequate clearances around fixture to allow for proper heat dissipation and fire hazards. The luminaire produces a significant amount of heat and should not be installed in any confined space. Any combustible materials or structures that could limit the airflow around the luminaire heatsink must be at least 36in away from the luminaire (example ceiling). Mounting structures, adjacent fixtures or non-combustible materials can be within this limit.

1 Yoke Mount

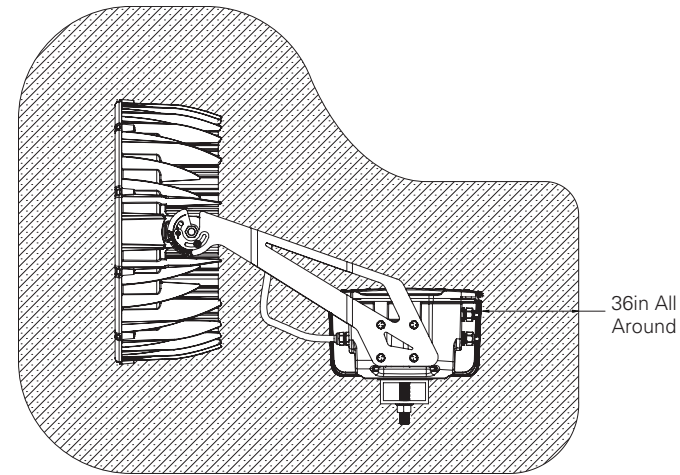

**Risk of Fire.** Do not install fixture within 36 in (915 mm) of any combustible material.

#### Optical Clearances – Maximizing Light Levels

The best sports lighting projects are designed using light modeling software. Install fixtures according to the location and aiming data exported from photometric models to achieve desired results. However, Any objects in the light path between the luminaire and the playing surface will diminish the light levels. Some examples of obstructions are building structural members, electrical panels, HVAC ductwork, banners, and scoreboards.

Before installing your lighting project, verify that there is a clear line of sight from every luminaire location to the designed aiming area, which includes not only the aiming point coordinate but also the area surrounding that aiming point. Identify all obstructions and analyze how each will impact the light output on the playing surface, and then take corrective action as necessary to avoid the obstruction. For example, a structural beam directly in front of a luminaire will block the light from reaching the target, so in that case, the luminaire should be shifted to avoid the beam.

2 Yoke Mount

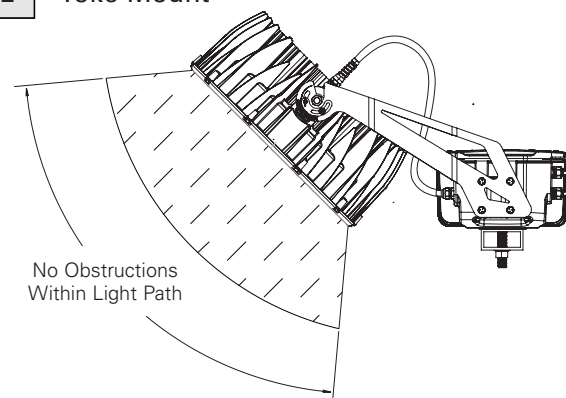

### Mechanical Clearances - Avoiding Obstructions

In general, fixtures can be moved up to 5ft from the designed location without affecting photometric results as long as they are aimed at the designed aiming coordinates. For significant obstructions, photometric models should be revised with accurate obstruction dimensions to provide new fixture location and aiming data that avoids the obstruction. If options are limited, consider swapping that fixture aiming with a nearby fixture of the same type that allows clear line of sight to the aiming points. Consult your photometric designer for assistance with finding solutions to major obstructions for your project. Proper planning will ensure the best results for your sports lighting project. Once these steps are completed, then proceed to the luminaire installation.

#### Operational Working Clearances

3a Yoke Mount

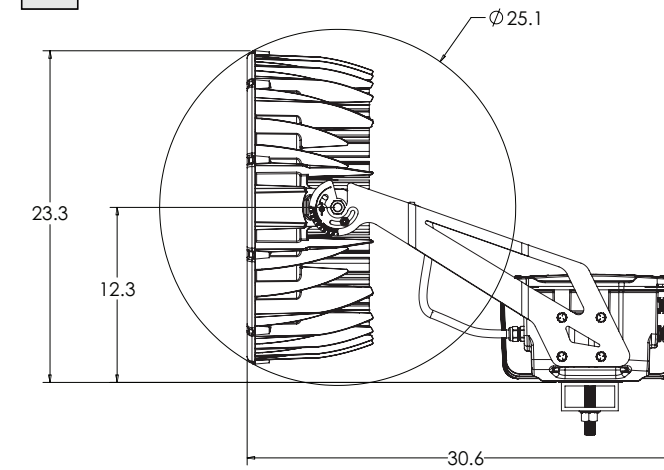

3b

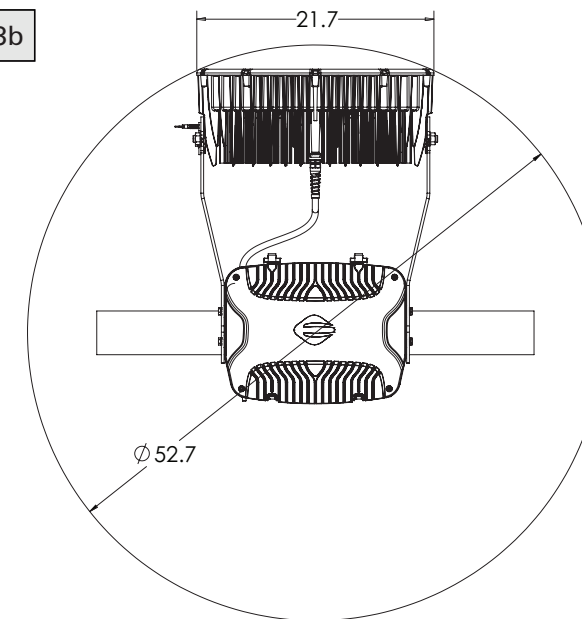



## Installation Instructions

### Step 1 – Prepare the luminaire



LumaSport Driver Box and Light Head must have matching power ratings. **Do NOT** install Light Head on a Driver Box that has a different power rating. Failure to properly match Driver Box and Light Head can damage the fixture.

**Note:** All fixtures that have the exact same model number are functionally identical as built from the factory.

### Prepare the Driver Box

Open the Driver Box cover by unlatching the two bail latches in the back and making sure the four top screws are fully loosened.

4a

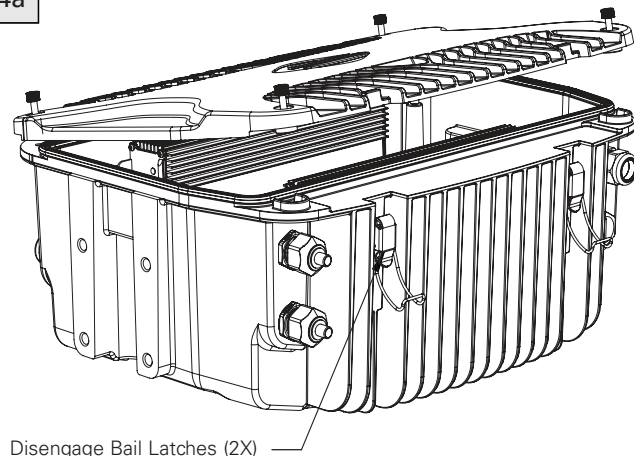

4b

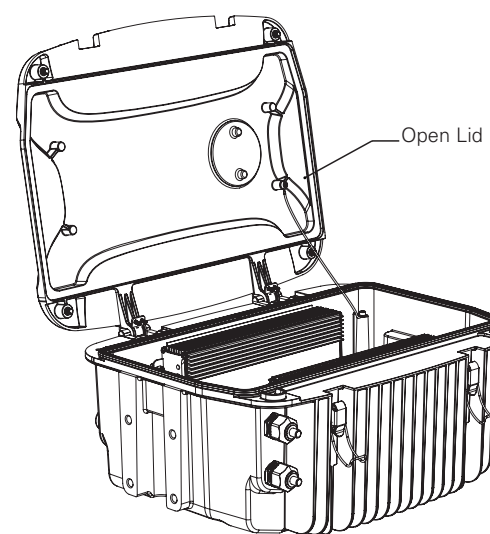

### Install power cable

Always turn all fixture power sources OFF before performing any work on power or control wiring. Failure to disconnect all power sources may lead to damage, injury, or death.



Incoming power cable must be SOOW style 3C cable with a minimum of 14AWG annealed stranded bare copper per ASTM B-174 with a minimum temperature range of -40°C to +90°C. Cable must be water resistant, UV rated/sunlight resistant, UL listed, and CSA certified for indoor and outdoor use. The cable jacket diameter must be within .260in - .545in.

Insert power cord through the top cord grip on the left side of the back of the Driver Box as shown in the images below.

### 5a Top Down View of Open Driver Box

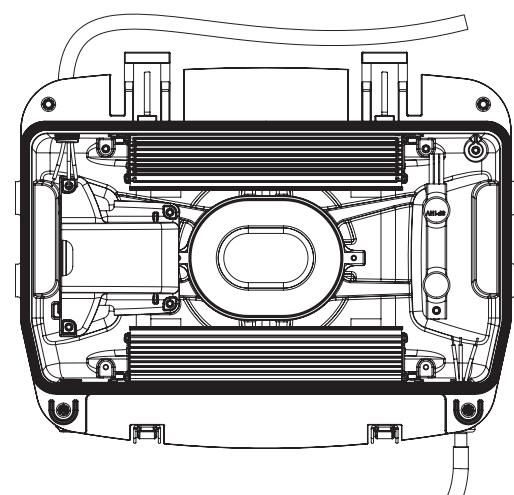

### 5b Closed Driver Box in Local Yoke Mount Configuration

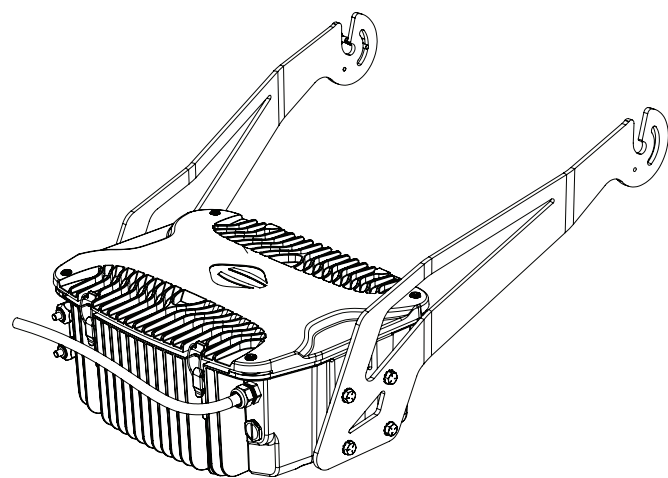

### 5c Correct Installation

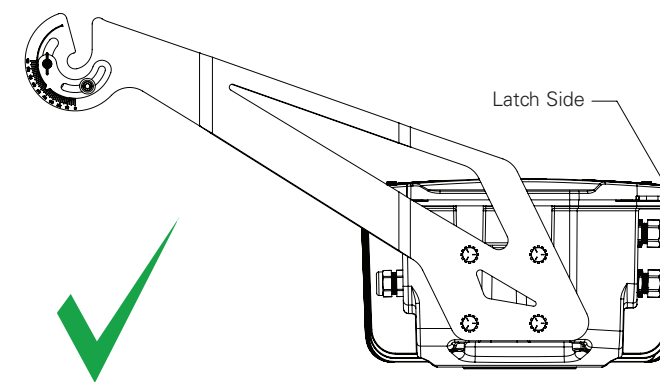

### 5d Incorrect Installation

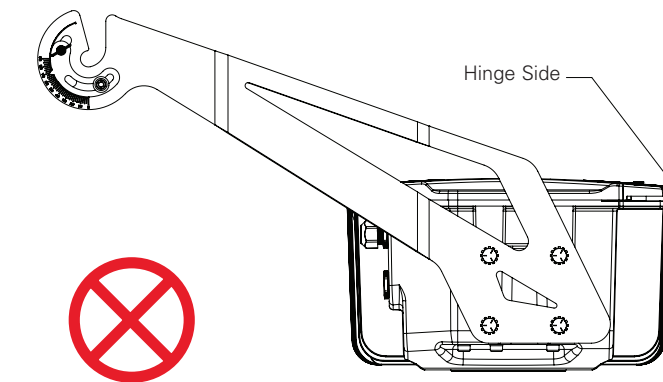

5e

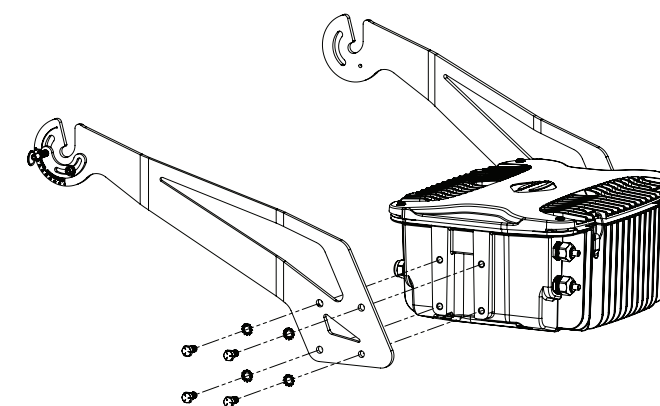

Connect incoming power cable wiring to fixture power supply wires using the Wago connectors:

Fixture Power Wire Color	Designation
Black	Line
White	Line or Neutral
Green	Ground

Tighten the power cable cord grip hand tight plus one full revolution using the 27mm cord grip tool to secure the cord in place so that it does not slide when pulled. Do not overtighten the cord grip to prevent damage to the cord.

### Label the Luminaire

Label each luminaire with the fixture number. Recommended label for indoor applications is white background with black lettering at least 1/2in tall. Paint markers or other methods may also be acceptable – verify with owner. Affix label to fixture Driver box or mounting bracket in a prominent location.

**Note:** Cooper Lighting also recommends labeling or otherwise marking the fixture number on the catwalk bracket or mounting structure to facilitate fixture identification from the catwalk or working area.

### MAINS IN

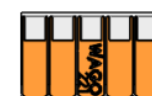

AC Line (PSU 1)  
AC Line (PSU 2)  
Surge

Black



AC Neutral (PSU 1)  
AC Neutral (PSU 2)  
Surge

White



Earth Ground  
Ground (PSU 1)  
Ground (PSU 2)\*  
Surge

Green





Failure to label the luminaire upon addressing may result in improper installation and system malfunction.



### Arm Prep

The arms are shipped separated from the driver box and they must be attached before installation of the light head. To install the mounting arms, use the provided bolts and lock washers to secure the mounting arms to the side of the box. There are 4 bolts and lock washers for each side. Ensure that the arms are positioned so the aiming graphics and quick mount orientation are in the position shown in the image below. In this configuration, the box will be inverted when mounted and the lid will open down.

Hardware Description	Use / Location	Quantity	Torque	Tool
3/8in-16 Hex Head W/ Lock Washer	Mounting Arms to Driver Box	8X	18 ft-lb	9/16in socket



### Step 2 – Install the Driver Box

#### Driver Box Orientation

Driver Box must be installed on a flat and level surface.



### WARNING

Failure to install Driver Box in approved orientation or location may result in damage, injury, or death.



**Yoke Mount** – The Driver Box with Yoke mounting bracket must ALWAYS be with the quick mount slots and lid facing up. Do NOT install the Driver Box with yoke mounting bracket in any other orientation. The yoke mount configuration is wet location rated.

6a

#### Correct Installation

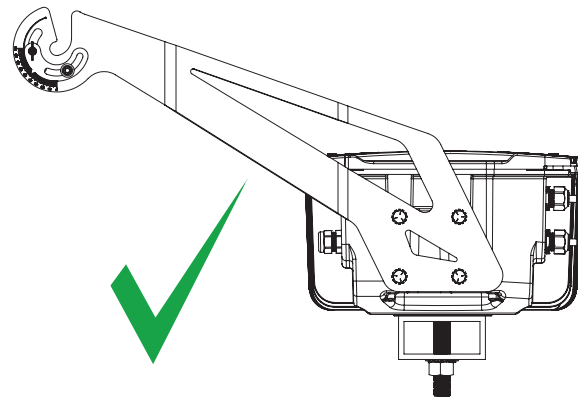

6b

#### Incorrect Installation

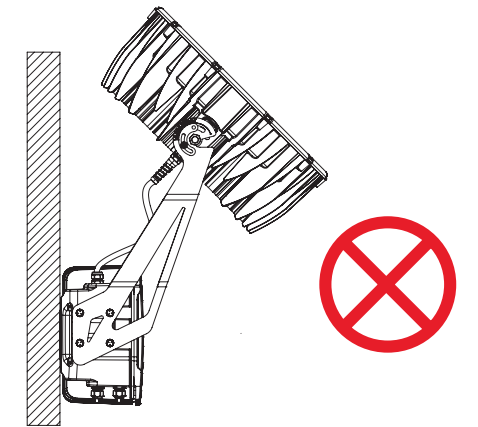
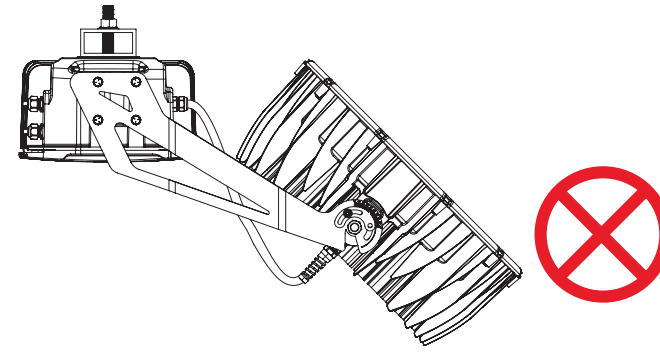
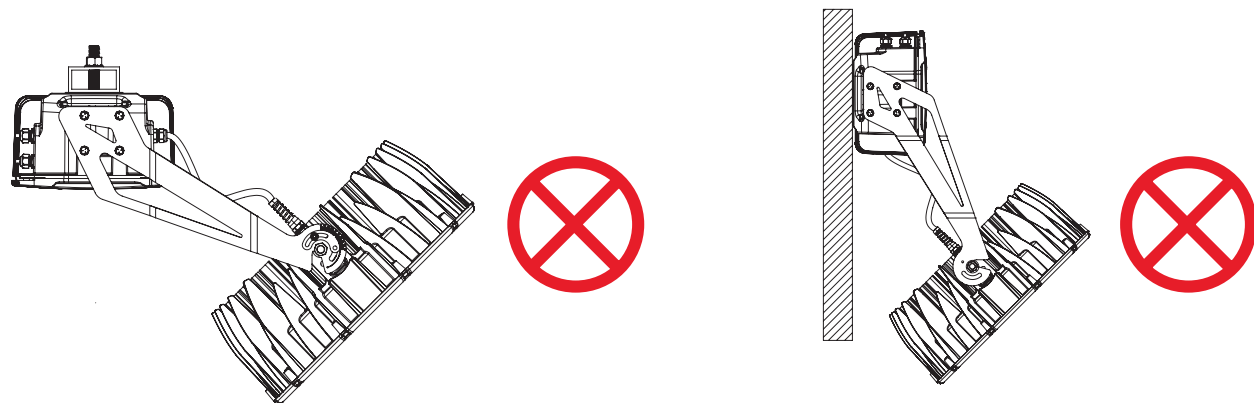

### Mounting Hole Dimensions

7

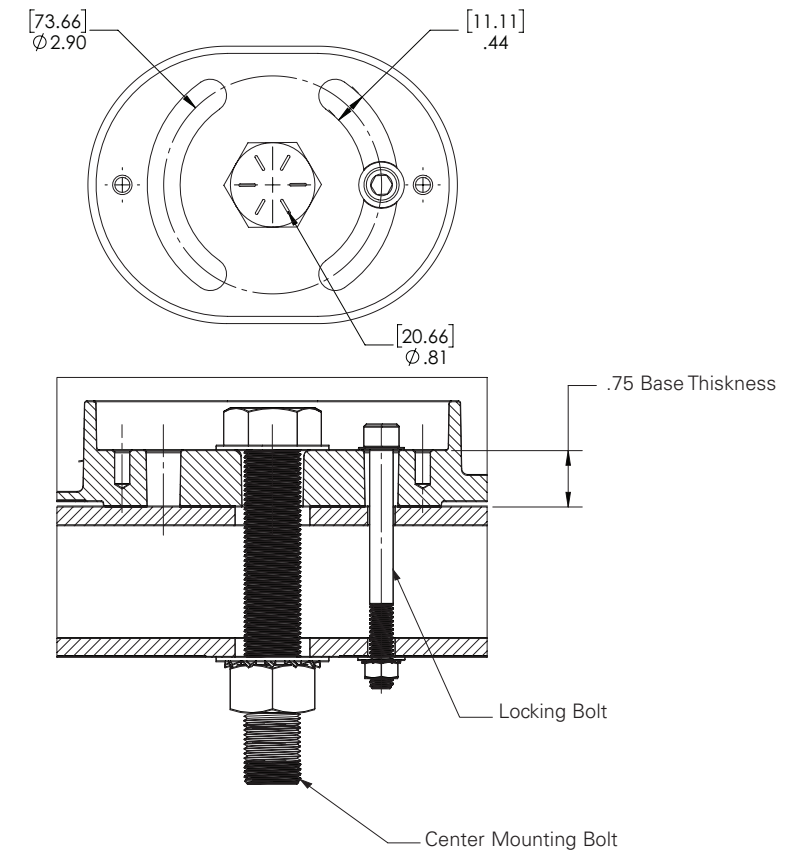

The Driver Box mounting hole is located underneath the orange cover on the base of the driver box. The central hole is sized for a 3/4in bolt and the crescent shaped features are sized for a 3/8in bolt.

#### Mounting Hardware (Surface Mount)

Mounting center bolt shall be 3/4in diameter corrosion resistant steel (HDG, hot dipped galvanized high-strength steel is recommended) with nut, jam nut and locking washers. A secondary 3/8in diameter corrosion resistant steel bolt with nut, flat and locking washers must be used to lock the orient. The length of bolts is determined in the field depending upon thickness of mounting structure. Size bolts appropriately to allow secure fastening of the luminaire to the mounting structure. Tighten hardware so that fixture is secure but do not fully torque hardware until aiming is complete.

**Mark the mounting surface (Pre-Aim Orientation)**

To pre-aim the fixture orientation, draw a reference line on the mounting surface. Use a paint pen or other marker to draw a line across the center of the mounting hole, parallel with the crossarm or mounting structure. This should typically but not necessarily be perpendicular to the direction of the field of play. The line should extend at least 3in out from the center of the mounting hole.

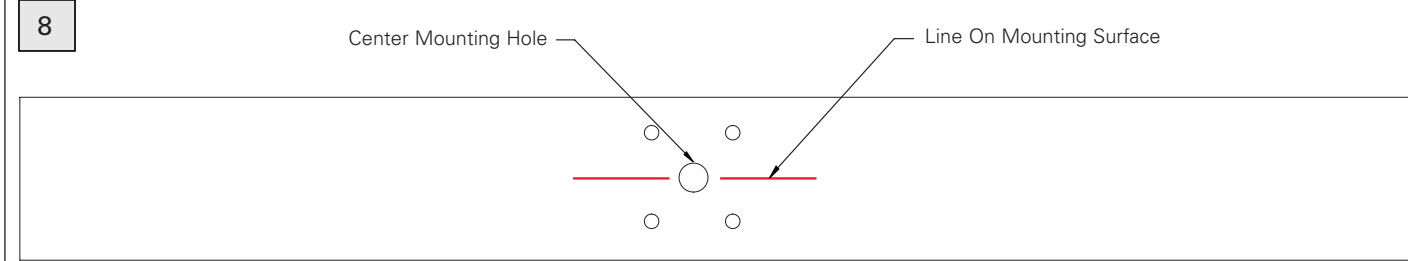

**Install the Driver Box**

Remove orange mounting hole cover inside Driver Box. Set Driver Box on the mounting structure so that the center hole in the bottom of the Driver Box is aligned with the mounting hole. The mounting arms should be facing the general aiming direction. Install bolt, washers, and nut to securely fasten the box to the mounting structure.



9 Local Yoke Mount

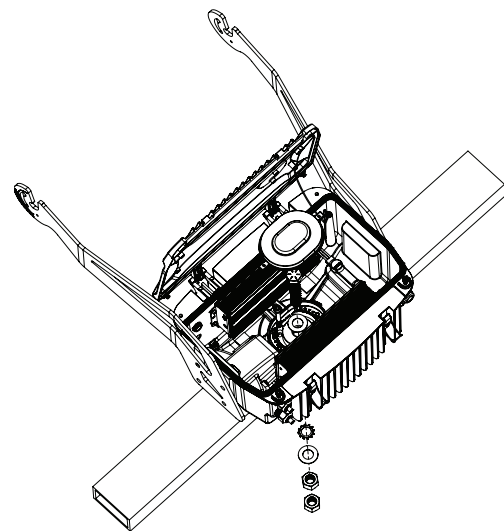

**Orient the driver box (Pre-aim Orientation 0-55°)**

To pre-aim the fixture orientation, rotate the Driver Box about the mounting bolt until the parallel reference line that was marked on the mounting structure is aligned with the correct angle shown in white on the orient label in the bottom of the Driver Box.

10a 90-180° Left

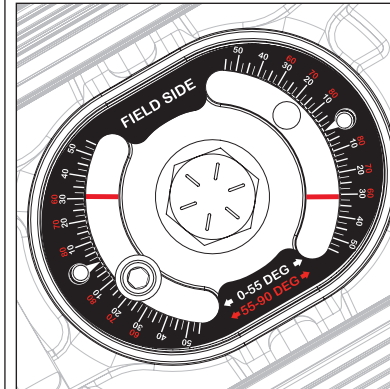

10b 90° Straight to Field

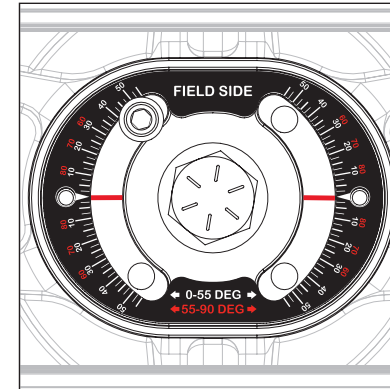

10c 0-90° Right

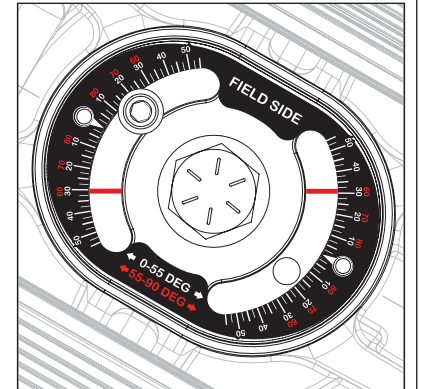

**Orient the driver box (Pre-aim Orientation 55-90°)**

To pre-aim the fixture orientation, rotate the Driver Box about the mounting bolt until the perpendicular reference line that was marked on the mounting structure is aligned with the correct angle shown in red on the orient label in the bottom of the Driver Box.

11a 55-90° Left

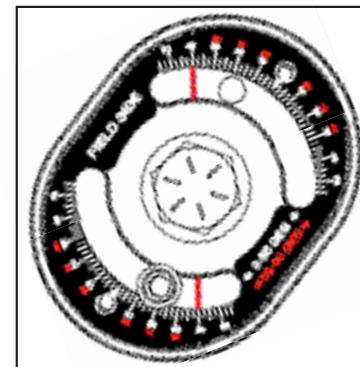

11b 55-90° Right

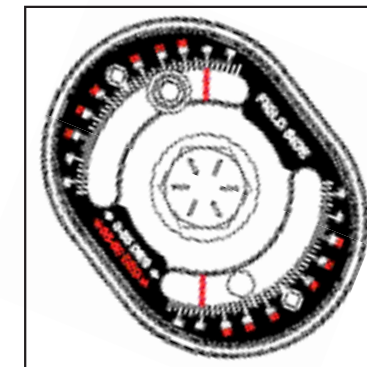

If laser aiming, tighten the mounting hardware so that fixture is secure but do not fully torque hardware until final aiming is complete.

Prevent access to area under fixture until the final torquing is complete.

If using the orient gauge, torque the mounting hardware at this step to the values in the table below. If you are laser aiming,

Hardware Description	Use / Location	Tool	After Aiming Torque	Quantity
3/4in Mounting Bolt Assembly	Mounting Fixture To Mounting Structure	1-1/8in Socket	65 ft-lb	1X
3/8in-16 Locking Bolt Assembly	Orient Lock	9/16in Socket	20 ft-lb	1X



### Mounting Accessories

#### Diving Board Kit

Diving Board is intended to only to mount to 2in x 4in steel cross arms. Designed to be used with the LUMASPORT 8 and LUMASPORT 16 luminaires only. Do not use in unapproved luminaires or mounting applications.

### WARNING



Diving Board may ONLY be installed in the following physical orientations. Failure to install the Diving Board Kit in approved orientation or location may result in damage, injury, or death. (Reference diagram DB4a and DB4b)



Prevent access to area under fixture until the final torquing is complete.

DB1 Diving Board Kit

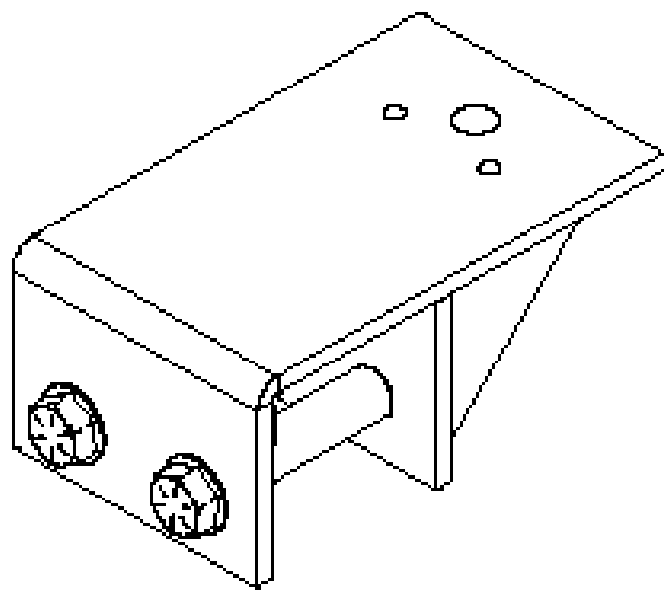

DB2 Diving Board Kit Parts Diagram

Item #	Description	Quantity
1	Diving Board Bracket	1
2	Bolt Sleeve	2
3	3/4in-10 X 6in Structural Hex Bolt, Hot Dip Galvanized	2
4		
5		
6		
7		

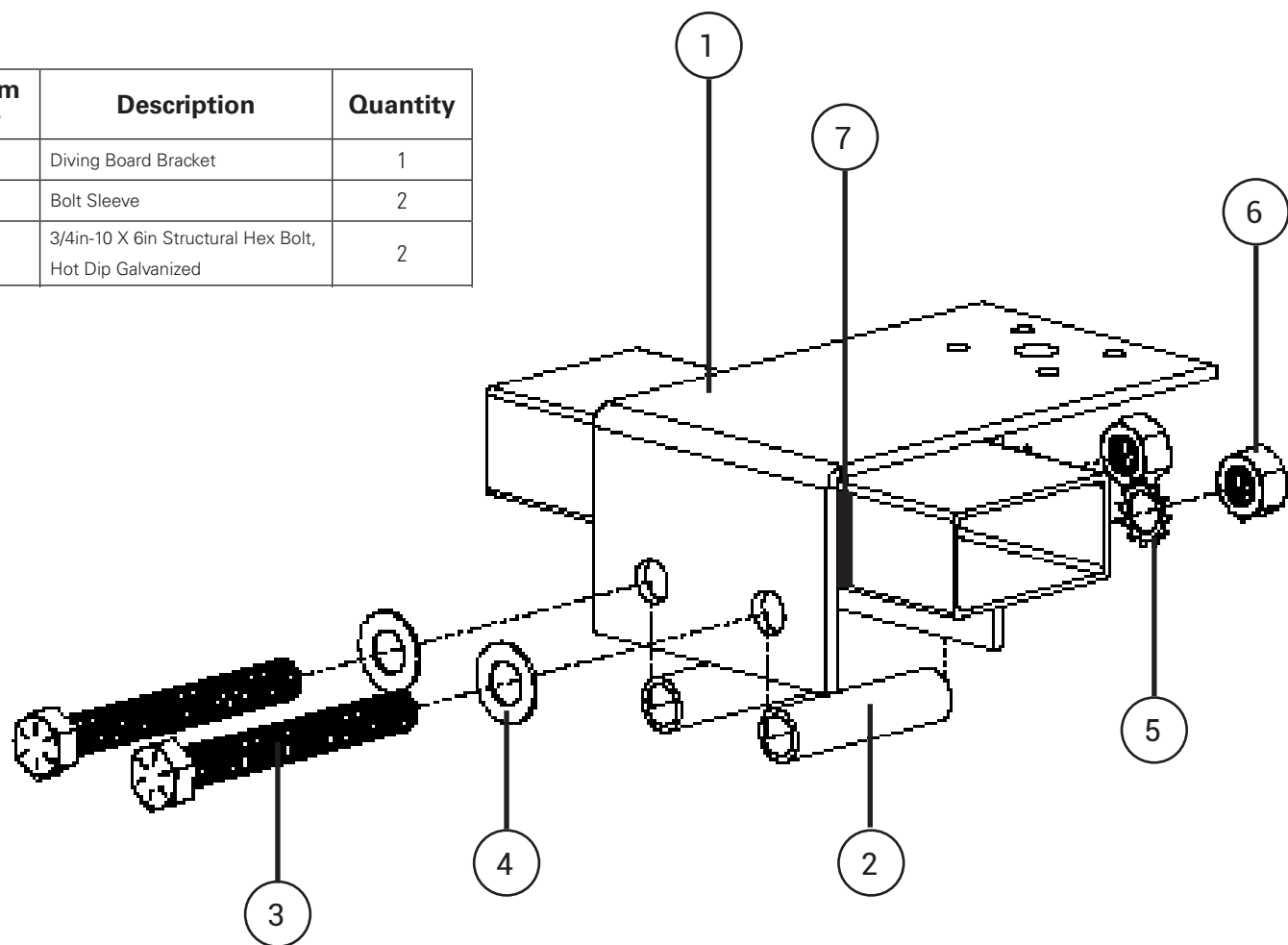

### Diving Board Kit (DVGBRD) Hardware

Hardware Description	Use / Location	Tool	After Aiming Torque
3/4in-10 X 6in Structural Hex Bolt, Hot Dip Galvanized	Diving Board is intended to only to mount to 2in x 4in steel cross arms.	<ul style="list-style-type: none"> <li>1 1/8in Socket &amp; Ratchet</li> <li>9/16in Socket &amp; Ratchet</li> <li>Adjustable Crescent Wrench</li> <li>Adjustable Torque Wrench</li> </ul>	120ft.-lb.

### Additional (HRDM34) Mounting Fastener Hardware Kits

Hardware Description	Use / Location	Tools	After Aiming Torque
HRDM34-025	Additional mounting fastener hardware kit needed to attach a fixture to the DVGBRD = Diving Board	<ul style="list-style-type: none"> <li>1 1/8in Socket &amp; Ratchet</li> <li>9/16in Socket &amp; Ratchet</li> <li>Adjustable Crescent Wrench</li> <li>Adjustable Torque Wrench</li> </ul>	65ft.-lb
HRDM34-075	.50-.75in clamping thickness, flat surfaces drilled for 3/4in hardware		
HRDM34-200	2.00in clamping thickness, use for 2in x 4in Cross arms that are drilled for 3/4in hardware		



### Steps to Install

- The Diving Board is mounted on top of the cross arm with bolts and sleeves mounted underneath to clamp the bracket to the crossarm and secure it. (Refer to the Diving Board Parts Diagram) Only mount it as shown
- Hold Diving Board Bracket (item 1) on top of cross arm.
- Optional: Place provided shim between side of bracket and cross arm if there is excessive clearance
- Insert both Clamping Hex Bolts through Washer, Bracket, Bolt Sleeve, other side of Bracket, Lock Washer, and Hex Nut.
- Torque 3/4in-10 X 6in Structural Hex Bolts: 120ft.-lb.
- Hold Fixture on top surface
- Use hardware kit HRDM34-025 for mounting fixture to bracket. Insert 3/4in Fixture mounting bolt through Flat washer, fixture, and primary mounting hole on Diving Board, Flat Washer, Lock Washer, and Hex Nut
- Use hardware kit HRDM34-025 for mounting fixture to bracket. Insert 3/8in secondary mounting bolt through Flat washer, fixture, and any secondary mounting hole on Diving Board, Flat Washer, Lock Washer, and Hex Nut
- Torque fixture bolts:
  - Primary fixture 3/4in bolt torque: 65ft.-lb.
  - Secondary fixture 3/8in bolt torque: 20ft.-lb.

DB3 Diving Board Kit (DVGBRD) with Additional (HRDM34) Mounting Fastener Hardware Kit

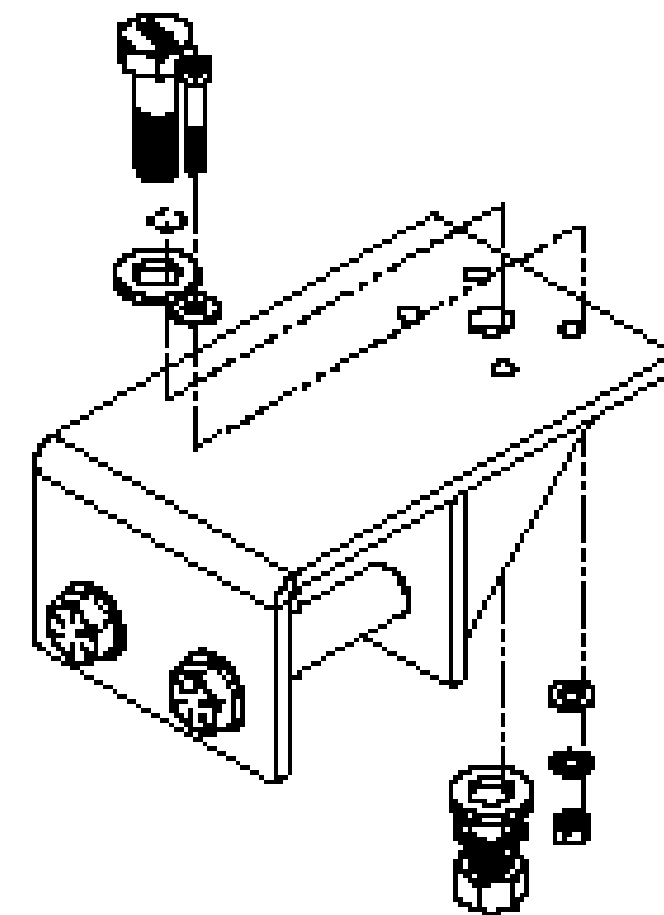

DB4a **Correct Installation**

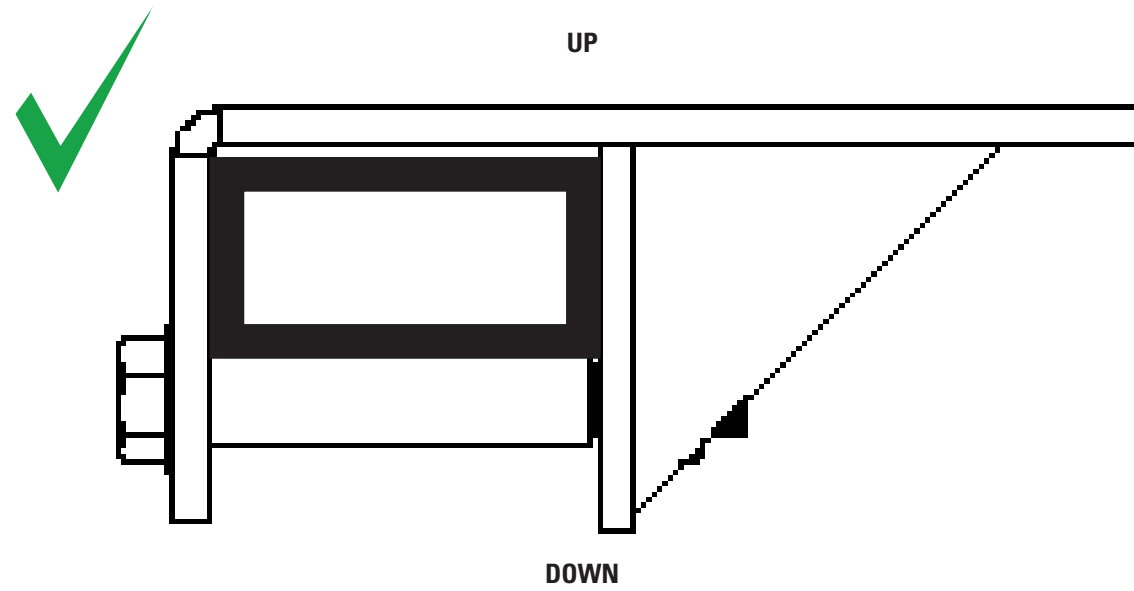

DB4b **Incorrect Installation**

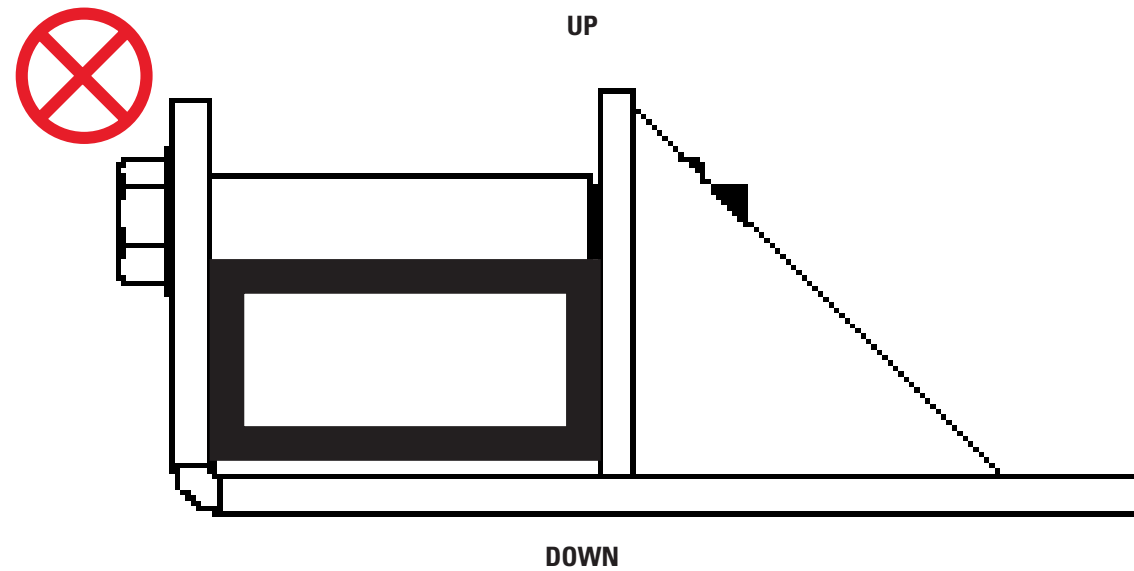

**Install control cables (Wired DMX Configurations)**

**Note:** For wireless applications, skip to Record MAC Address step.

Control Standards: All control work must conform to ANSI E1.11 – 2008 (r2013), USITT DMX512-A, Asynchronous Serial Digital Data Transmission Standard for Controlling Lighting Equipment and Accessories. At a minimum, DMX cable should be 1-pair (24AWG, 7x32 Stranding) Twisted (minimum of 4.8 twists/foot), Shielded, minimum of 100 ohms impedance, and <25pF/ft. Capacitance.

Install control cables through the cord grips on the back right side of the Driver Box.

**DMX IN**

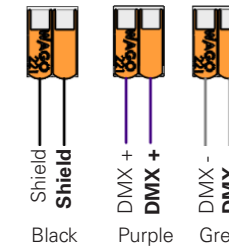

**DMX OUT**

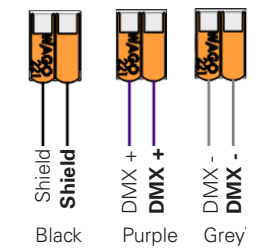

Tighten power cable cord grip hand tight plus one full revolution using the 24mm cord grip tool to secure the cord in place. The cord shall not slide when pulled. Do not overtighten the cord grip to prevent damage to the grip and cord.

12a

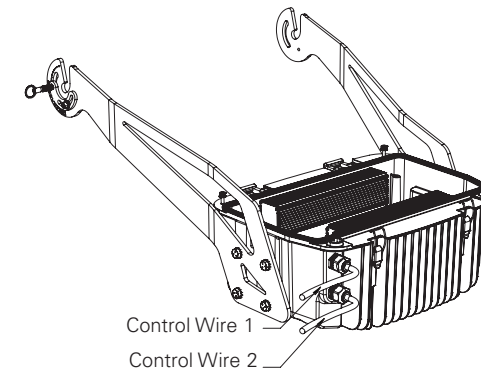

12b

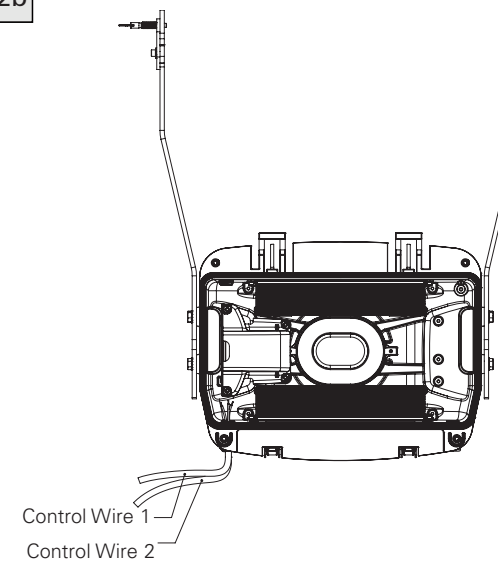

**Record MAC address (Wireless AirMesh configurations)**

**Note:** No control cables are required for wireless applications.

For wireless applications, every fixture also has a unique MAC address. It is important to record that MAC address for each fixture with the corresponding fixture number to ensure the control system programmers can identify each fixture.

Every fixture that has wireless control capability will have a sticker inside the driver box that has the MAC address of the wireless control card that was installed in that fixture. Remove the sticker from the inside of the driver box and place it on the MAC address recording sheet. If you do not have a MAC address recording sheet, simply affix the sticker to a piece of paper and write the fixture number next to the sticker. Keep all MAC address stickers in a safe location and provide them to the Controls Technician.

**Step 3 – Install the Light head**

**Set pre-aiming tilt angle**

The Light head tilt angle can be rough-aimed using the guide on the left mounting arm. Retract spring plunger by pulling the clip and rotating it into the locking position. Loosen the tilt lock screw slightly to allow the aiming plate to rotate.



Do NOT over-loosen or remove tilt lock screw. Prevent access to area under fixture until the final torquing is complete.

13

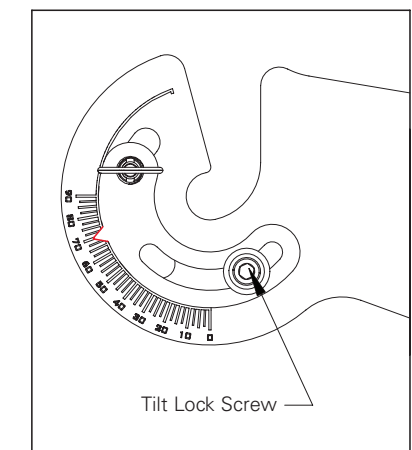

**Note:** Example shown at 70° tilt. Minimum tilt of 15\* when using a wireless configuration.

Connect to fixture control wires as follows:

	Fixture DMX Control Wire Color	Designation
Input	Grey	DMX -
	Purple	DMX +
	Black	Shield
Output	Grey	DMX -
	Purple	DMX +
	Black	Shield





### 14a Spring Plunger Disengaged

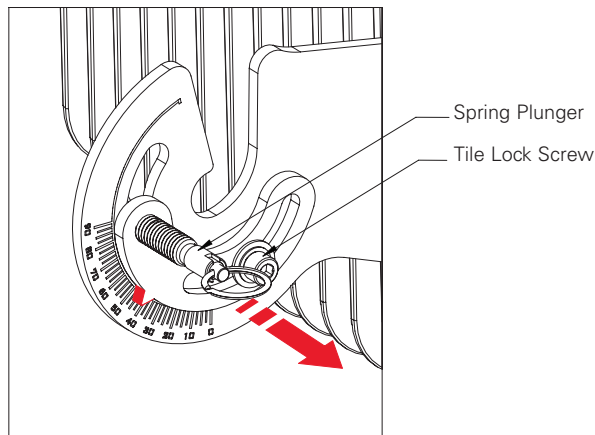

### 14b Spring Plunger Engaged

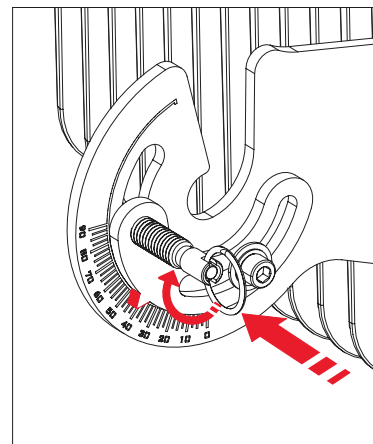

Rotate the labeled aiming plate until the arrow is over the desired tilt angle. Hold the aiming plate in place and tighten the tilt lock screw.

If laser aiming, tighten the tilt lock screw so that fixture is secure but do not fully torque hardware until final aiming is complete.

If using the tilt gage, torque the tilt lock screw to:

Hardware Description	Use / Location	Tool	After Aiming Torque	Quantity
1/4in-20 Screw	Tilt Lock	3/16in Allen	75 INCH LBS	1X



DO NOT REST LIGHTHEAD ON THE CORD GRIP



### Install the Light Head

Install the Light head with the screw-in vents on the bottom and toward the driver box. The Laser Aiming Pin feature should be on the top. Set the Light head in place so that the side mounting bolts drop into the notches in the mounting arms. Be careful of AirMesh module (wireless configurations) when installing Light head. Do not damage module.

#### Yoke Mount

15a

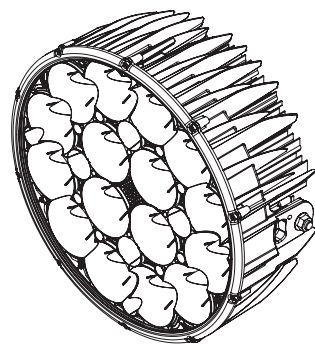

15b

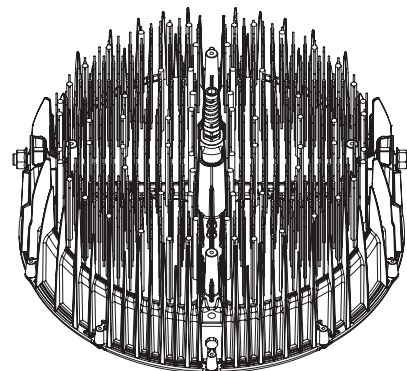

15c

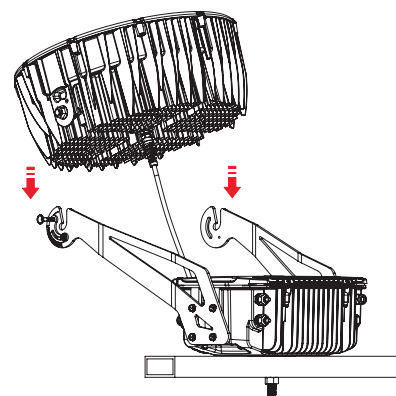

15d

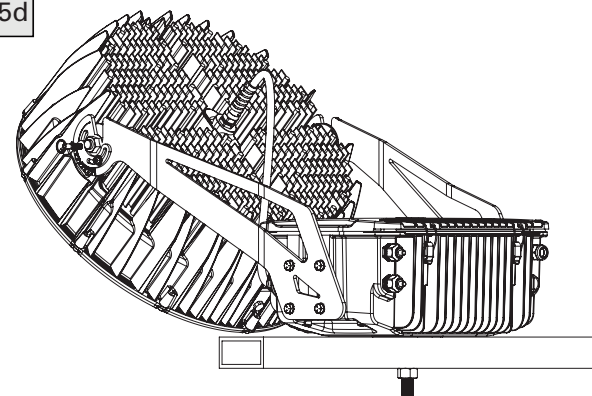

Rotate the Light Head to the approximate tilt angle and release the spring plunger. The plunger will engage when the Light Head is at the correct tilt angle.

If laser aiming, tighten the Light Head nut so that fixture is secure but do not fully torque hardware until final aiming is complete.

If using the tilt gage, torque the Light Head nut to:

Hardware Description	Use / Location	Tool	After Aiming Torque	Quantity
5/8in-11 Nylock Nut	Light Head Mounting Nut	15/16in Socket	40 ft-lb	2X

### Wire the Light Head to the Driver Box

Insert the Light Head cable into the Driver Box through the cord grip on the front left side of the Driver Box. Leave some slack in the cable to allow for aiming adjustments. Tighten cord grip hand tight and then tighten one additional revolution. The cable should not slide if the cable is pulled.

#### Yoke Mount

**Note:** Mounting infrastructure components removed for demonstrated clarity.

16a

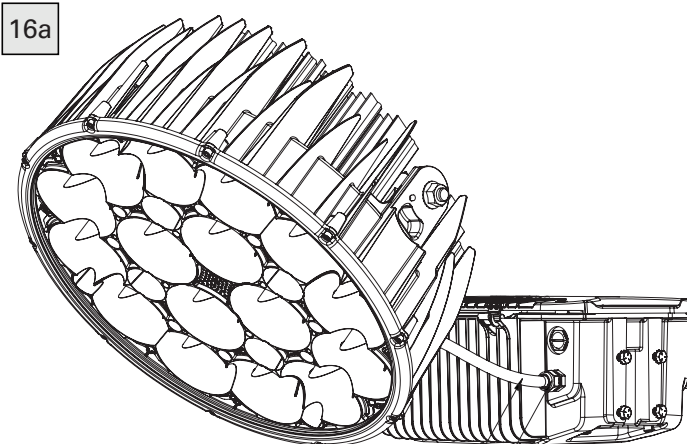

16b

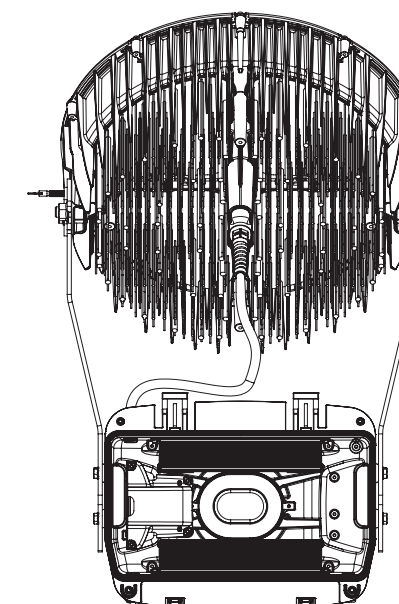

Light Head DC Cable  
Tighten The Cordgrip After Wiring

Connect the Light Head cable using the Wago connectors.

Light head Wire Color	Driver Box Wire Color	Designation	Comments
Light Green	Dark Green	Ground	
Light Blue	Dark Blue	DC Return	
Light Red	Dark Red	PSU 1	DC from Power Supply
Light Red	Dark Red	PSU 2	DC from second Power Supply (for Lumaspot 16 configurations)

### LIGHTHEAD

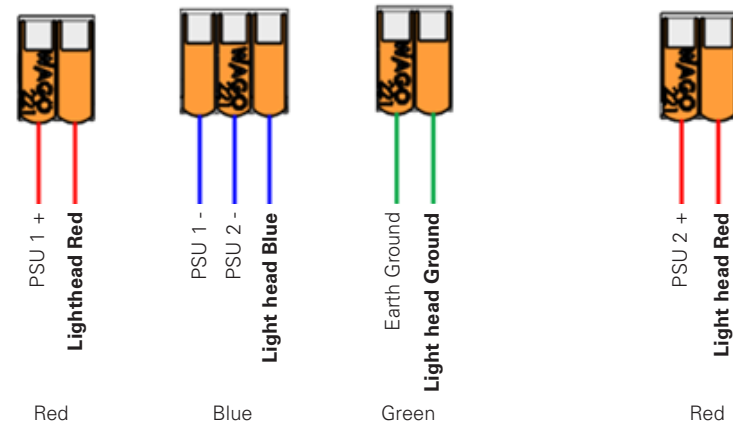

PSU 2 connections only apply to 640W models. The two red wires from the Light Head are interchangeable and may be connected to either Power Supply feed.



## WARNING

Prevent access to area under fixture until laser aiming is completed.



### Step 4 – Aiming

#### Laser Aiming

If fixture pre-aiming using the tilt and orient gages is satisfactory and laser aiming is not required, you can skip this step.

Refer to photometrics or project installation drawings for aiming point coordinates.

Slightly loosen the fixture aiming screws just enough to allow the fixture to rotate and tilt.

Insert the aiming mount onto the fixture aiming pin until it is fully seated tight against the fixture



Do NOT over-loosen or remove set screw.

17a

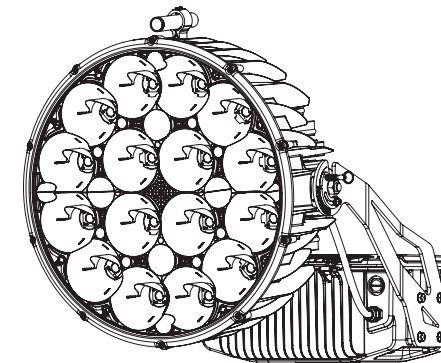

17b

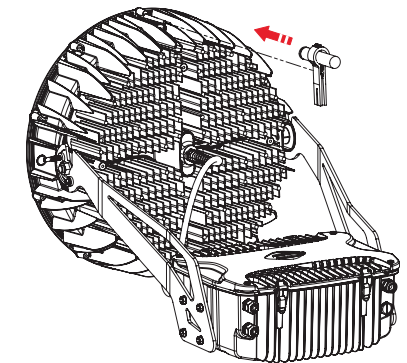

Turn on the laser and aim the fixture by targeting the laser dot at the aiming point.

**Note:** Turn off laser while not in use to conserve battery. Have spare battery charged to facilitate the aiming process.

#### Tighten All Hardware

After the fixture is aimed. Tighten all mounting and aiming hardware on the light head and driver box to the torques specified in the table below.

Hardware Description	Use / Location	Tool	Torque	Quantity
3/4in Mounting Bolt Assembly	Mounting Fixture To Mounting Structure	Deep Socket	65 ft-lb	1X
3/8in-16 Locking Bolt Assembly	Orient Lock	9/16in Socket	20 ft-lb	1X
1/4in-20 Screw	Tilt Lock	3/16in Allen	75 in lbs	1X
5/8in-11 Nylock Nut	Light Head Mounting Nut	15/16in Socket	40 ft-lb	2X

If laser aiming, briefly turn the laser back on to verify that the luminaire aiming did not shift during tightening.

Remove the aiming mount from the fixture.



### Step 5 – Final Steps

#### Final inspection

To complete the installation, verify that all mounting, connection, and aiming work is finished.

Before securing the driver box lid, verify all electrical connections are tight and secured. Ensure the integrity of all connections.

Verify all bolts and screws are tightened and properly torqued.

Straighten up all cabling. Tie down all cables neatly. For all outdoor projects, use UV rated tie wraps and wire management.

#### Close the Driver Box

Re-install the orange mounting hole cover over the mounting hole inside the Driver Box. Even in indoor applications, this cover should remain in place to keep dirt and debris out of the Driver Box.

Carefully push all wiring connections and lid straps (if applicable) inside the Driver Box and close the lid.



Make sure no wires are pinched in the cover.



Re-lock the bail latches. Tighten the captive driver box cover screws to:

Hardware Description	Use / Location	Tool	After Aiming Torque	Quantity
1/4in-20 Captive Screw	Driver Box Lid Screw	3/16in Allen	75 in lbs	4X

18

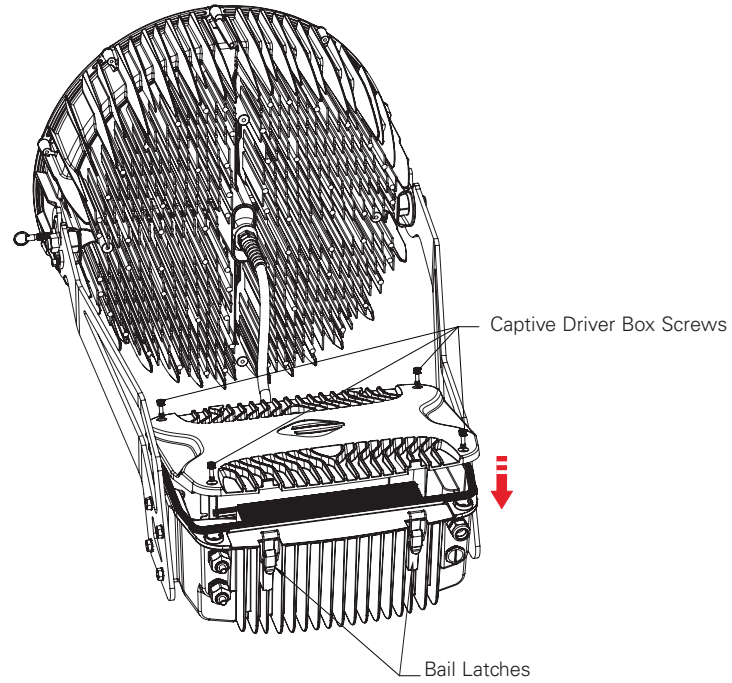

### Install Secondary Retention

If required, install a secondary retention cable between the fixture and the supporting structure that is designed to support the weight of the fixture, such as the crossarm, catwalk railing, or beam. Route the cable through the cable port located on the bottom edge of the fixture, through the mounting bracket arm, and around the support structure.

### Yoke Mount

19a

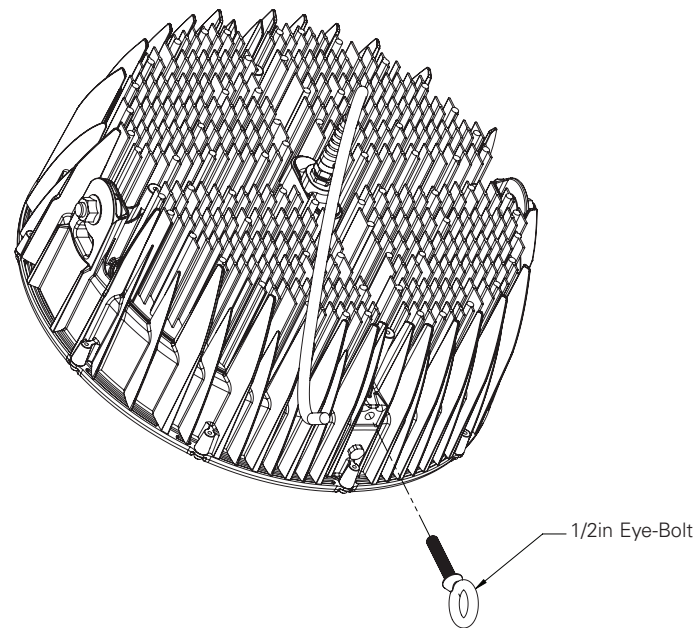

19b

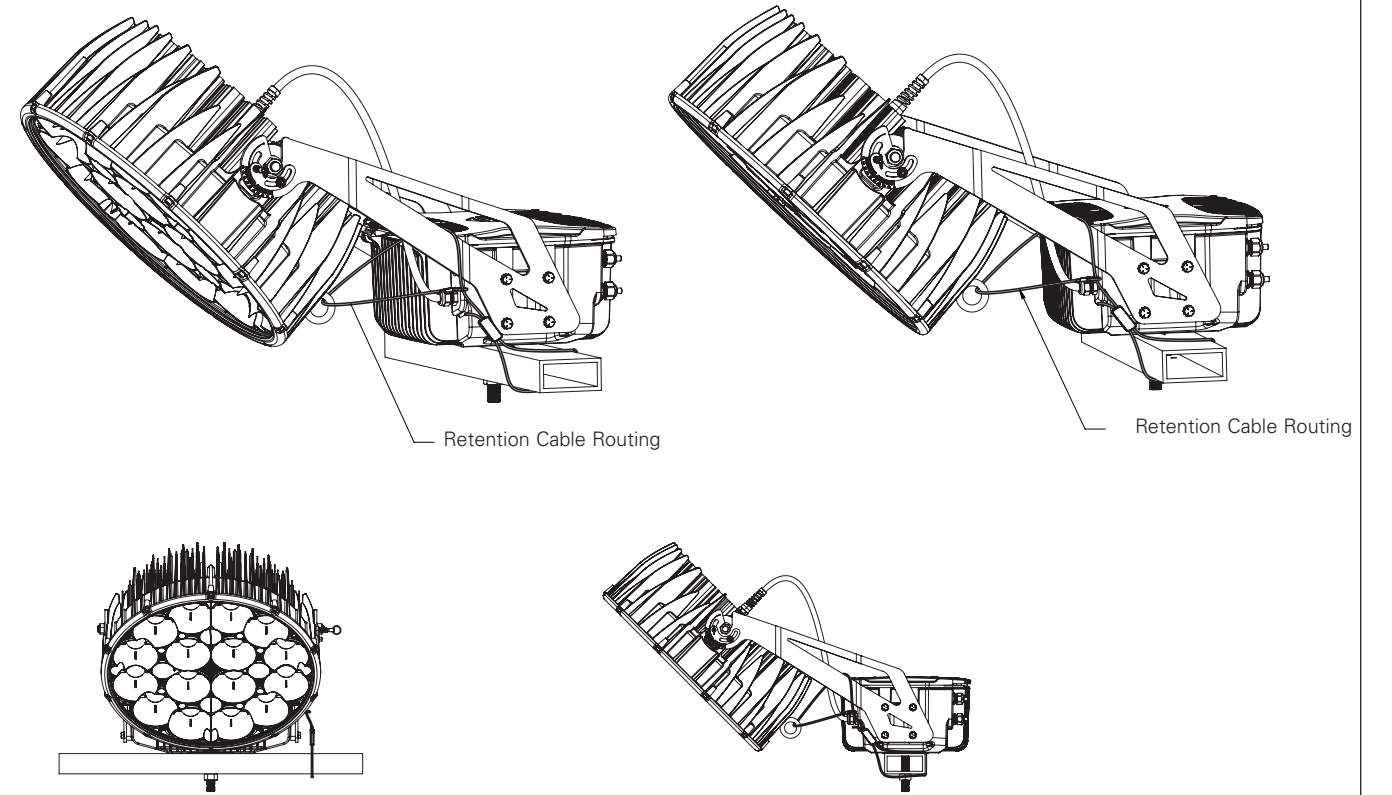

**Note:** Never secure the secondary retention cable to electrical conduits, power or HVAC equipment, other light fixtures, frangible material, or any other object not designed to support heavy loads.

Secure secondary retention cable to a structural component at a point above and directly behind the fixture if possible. Leave enough slack to allow fixture aiming if not completed, then pull extra slack through the locking clip after its aimed.

Recommended secondary retention cable is Gripple model #HF4-LT-10ft for indoor applications and equivalently sized vinyl coated cable with cable clamp for outdoor rated applications.



**WARNING**

Failure to properly install fixture and secondary retention cable may result in damage, injury or death.

### Luminaire Operation

#### Default Response

LumaSport fixtures will turn on to 100% full on when the AC power is applied.

#### Control Details

For luminaires equipped with wired DMX or wireless AirMesh Hub control, the luminaire can be turned on, off or dimmed using a front-end control system.

For DMX control, the LumaSport takes a single DMX channel. The start address can be set by using an RDM (Remote Device Management) tool such as DMXCat or front-end controls. DMX start addresses can be set as desired per project.



## Basic Functionality

When initial AC power is applied, the luminaires may have a fraction of a second delay and appear staggered for banks of lights.

The minimum light output on the fixtures is 10%. Therefore, the dimming range is 0, 10%-100%. A slight jump in light output may be perceived when dimmed up from blackout.

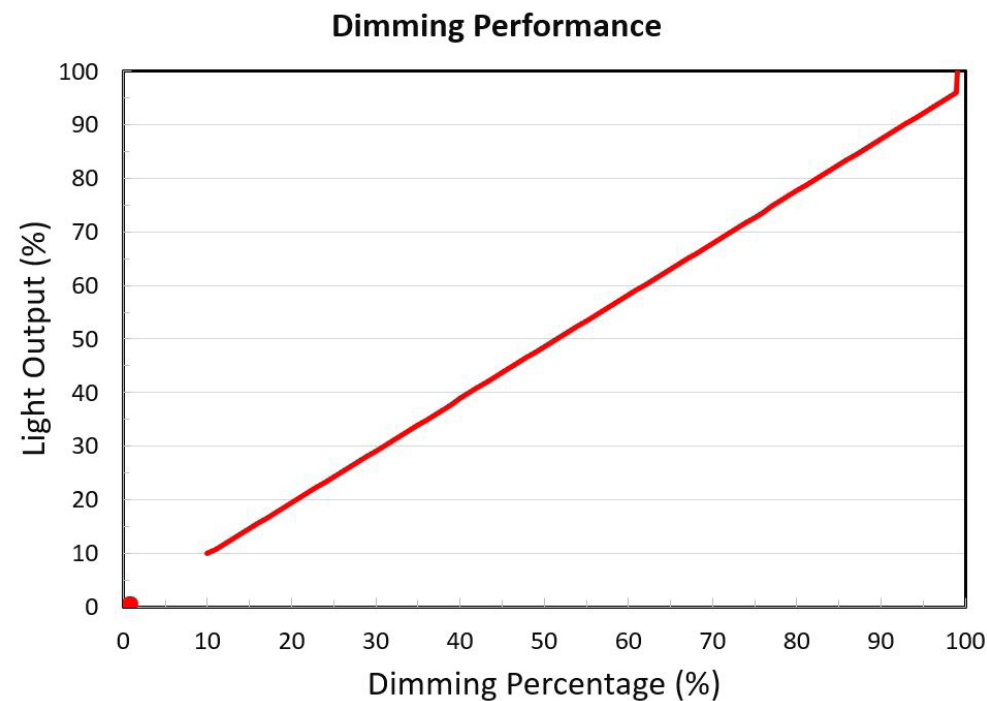

## Advanced Functionality

It is recommended that advanced or fast dynamic scenes are controlled up from blackout to a value greater than 40% and have a delay longer than 100ms between transitions. Strobe, chase or other synchronized dynamic scenes may appear staggered when the luminaire is controlled up from blackout to a value less than 40% or transition faster than 100ms.



## Maintenance & Preventative Maintenance

### Fixture Care and Maintenance

All luminaires are prepared with a powder-coated finish. The finish on exterior luminaires may weather over time, depending on the environmental conditions at the installation site. Proper care of the luminaires will maintain their performance and appearance.

Follow a regular maintenance schedule to retain optimal light output and thermal performance. Lack of preventative maintenance may disqualify owner from warranty. Not adhering to this minimum system cleaning requirement is considered negligence as outlined in product warranty documents. Refer to your product and/or labor warranty documentation for further details.

### Cleaning

1. Clean all luminaires at a minimum of once every 12 months from receipt of product.
2. Remove physical elements such as dirt, leaves and other foreign debris from the luminaire housing that can block and modify the air cooling (heatsink fins)
3. Wipe the optical lenses with a clean, dry, cotton cloth to remove dust and other contaminants. A non-abrasive optical cleanser or water may be used periodically.
4. Do not apply cleaners in direct sunlight or at elevated temperatures

### Inspection of Hardware

Inspect mounting system and products at least once every 12 months. Replace all rusted hardware elements.



## Troubleshooting

The LumaSport luminaire is designed to provide many years of reliable quality lighting. If the system appears to not be operating correctly find out as much about the issue as possible by asking the following questions:

1. **How many fixtures are not operating correctly?** If only one fixture is not responding, continue investigating at that fixture itself. If a group of fixtures are not responding correctly, start at the source of the power or controls for that group.
2. **Have any obvious external forces been in the area?** For instance, were any riggers, electricians, or other workers near the fixtures or controls? Have there been any power disturbances in the facility such as lightning storms?
3. **Are your fixtures responding according to the input control function?** Run the system through some different control scenes, including all on and then all off (blackout mode). Take note of any fixtures not responding correctly to the scenes.



## WARNING

Always disconnect power from the luminaire before opening the driver box.

Problem	Remedy
Luminaire does not power on	<ul style="list-style-type: none"><li>• Verify the power supply is on, at the proper voltage, and stable.</li><li>• Check connections at the source and at the fixture.</li><li>• Verify control signal is above 50%.</li></ul>
Luminaire does not respond to controls	<ul style="list-style-type: none"><li>• Reset the fixture by turning all power sources off for at least 10 seconds.</li><li>• Inspect all system control wiring to make sure there are no poor connections or breaks in the control wiring.</li></ul>

## Fixture Replacement

### Contacting Warranty Technical Support

1. Before you call, make sure you have completed the troubleshooting steps.
2. Gather as much detailed information as possible about the situation.
3. Have your fixture and project information handy, including the model number of the fixture in question.

Refer to your fixture warranty document for more information

If you have attic stock fixtures available and need to replace a fixture, simply follow the installation instructions in this manual to replace the fixture in question. Be sure to address the replacement fixture with the correct luminaire number.

All Luminaires, materials, and accessory equipment being returned through the warranty process need to be placed back in their original packaging in the same orientation that they were originally shipped from the factory. If the packaging is damaged or if there are questions on the orientation in returning equipment and materials, you need to contact the Warranty Department for replacement packaging materials at:

**EphesusWarranty@Signify.com | +1 (800)-573-3600**

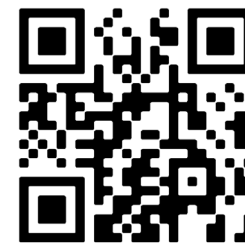

**CLICK OR SCAN  
FOR WARRANTY  
INFORMATION  
& CLAIM FORM**

### Warranties and Limitation of Liability

Please refer to [www.cooperlighting.com/global/resources/legal](http://www.cooperlighting.com/global/resources/legal) for our terms and conditions.