



LUMASPORT 8

White LED Sports Luminaire

Installation Manual



**ASSEMBLE: EPH-LS-08-0320L Light Head
ONLY WITH PART: EPH-LS-0320L Driver Box**

**ASSEMBLE: EPH-LS-08-0640L Light Head
ONLY WITH PART: EPH-LS-0640L Driver Box**

THIS PRODUCT MUST BE INSTALLED IN ACCORDANCE WITH THE APPLICABLE INSTALLATION CODE BY A PERSON FAMILIAR WITH THE CONSTRUCTION AND OPERATION OF THE PRODUCT AND THE HAZARDS INVOLVED

CE PRODUIT DOIT ÊTRE INSTALLÉ SELON LE CODE D'INSTALLATION PERTINENT, PAR UNE PERSONNE QUI CONNAÎT BIEN LE PRODUIT ET SON FONCTIONNEMENT AINSI QUE LES RISQUES INHÉRENTS



WARNINGS AND CAUTIONS

Follow all warnings and cautions outlined here as well as any local safety procedures. Failure to strictly adhere to the warnings and cautions as well as the installation instructions may result in serious personal injury or property damage

Before You Begin

Read and understand this entire manual and any additional site-specific installation documents before attempting to assemble, install, or operate the luminaire. If you have any questions regarding the product or installation, contact Cooper Lighting Customer Service at 1-800-573-3600.

1. All electrical work must conform to National Electrical Code (NFPA 70), IEEE Emerald book, and all applicable local codes and ordinances.
2. Verify the capacity and integrity of existing power distribution system and correct branch circuit voltage before beginning installation.
3. Verify the structural capacity and safety of all facility/venue/pole supports and mounting apparatus before installation. See fixture specification sheet for weight and wind loading data.
4. Verify that the capacity and integrity of all existing mounting structures and electrical distribution systems are compatible with the new lighting system and compliant with all regulatory and safety codes.
5. In harsh settings where the system is subjected to factors such as extreme temperatures, high corrosion, hurricanes, or lightning, always follow local codes and additional protocols to ensure the cabling and other system components can withstand the environmental stress for the life of the system.
6. DO NOT make or alter any open holes in the luminaire. Do not modify the luminaire, internal wiring, or fixture mounting features. Opening or modifying the luminaire or bracket will void the warranty.
7. Use Personal Protective Equipment including hardhats, safety glasses, reflective vests, electrical safety gloves, fall protection equipment, and safety toe boots during installation, operation, and maintenance of luminaire.
8. Verify compliance with local standards to prevent access to the area below where installation activities are occurring to prevent injury from accidental drops of fixtures, tools or hardware.

Storage

Store luminaires in a clean, dry place, protected from dirt, water, and sunlight prior to installation. See Table 1 for required storage and operating conditions:



Storage Temperature	Operating Temperature	Humidity
-40°C to +75°C (-40°F to 167°F)	-40°C to +40°C (-40°F to 104°F)	5% to 95% non-condensing

Table 1. Storage and Operating Conditions



Risk of Fire, Electrical Shock, Cuts or other Casualty Hazards - Installation and maintenance of this product must be performed by a qualified electrician. This product must be installed in accordance with the applicable installation code by a person familiar with the construction and operation of the product and hazards involved.



Risk of Fire and Electric Shock - Make certain power is OFF before starting installation or attempting any maintenance. Disconnect power at fuse or circuit breaker.



Risk of Fire - Refer to product label for specific minimum supply conductor requirements.



Risk of Burn - Disconnect power and allow fixture to cool before handling or servicing.



Risk of Personal Injury - Fixture may become damaged and/or unstable if not installed properly.

DISCLAIMER OF LIABILITY: Cooper Lighting Solutions assumes no liability for damages or losses of any kind that may arise from the improper, careless, or negligent installation, handling or use of this product.

NOTICE: Green ground wire provided in proper location. Do not relocate.

ATTENTION Receiving Department: Note actual fixture description of any shortage or noticeable damage on delivery receipt. File claim for common carrier (LTL) directly with carrier. Claims for concealed damage must be filed within 15 days of delivery. All damaged material; complete with original packing must be retained.

APPLICATIONS: This lighting fixture should not be used in area of limited ventilation or inside high ambient temperature enclosures. It must be stored in a dry location before installation. Do not expose lighting fixture to rain, dust or other environmental conditions prior to installation. Best results will be obtained if installed and maintained according to the following recommendations.



Required Tools and Materials

- 3/16in Hex driver
- 9/16in Socket w/ driver
- 15/16in Socket w/ driver
- 1-1/18in Socket w/ driver
- 27mm cord grip tool (24mm if wired controlled)
- Socket wrenches and/or crescent wrenches sized to fit mounting hardware
- Ephesus Laser Aiming Kit (if applicable)



Power Supply

Cooper Lighting Ephesus LED luminaires are not traditional metal halide lights; they are high-tech, new-generation solid-state devices. To protect your valuable investment, ensure the electrical power supply is clean and stable with no spikes or sags.

The power transformer feeding the site electrical distribution system must be a three-phase, four-wire wye configuration or a single-phase configuration. An ungrounded delta configuration is **NOT** an approved power supply. If any other supply transformer configuration is present, notify Cooper Lighting before proceeding with installation.

All issues with supply power must be corrected before luminaires are installed. Failure to use an approved power supply configuration may result in equipment damage.



Power Quality

Follow proper grounding methods. The electrical system must be properly grounded for power electronics in accordance with IEEE Emerald Book, including using equipment grounding conductors. Metallic conduits are **NOT** an acceptable grounding method for Cooper Lighting LED lighting systems. Power must also be phase balanced. If you are not sure if your power system is grounded or load balanced, **DO NOT** install the luminaire and contact a licensed electrician for information on proper grounding and balancing methods as required by the National Electrical Code and IEEE standards.



Surge Protection

Installation of surge protection is recommended in power distribution systems that feed LED sports lighting. Failure to protect electrical circuits from surges may result in damage to fixtures.



Branch Circuits

Branch power circuits feeding luminaires shall have a measured voltage of within 4% of nominal voltage with no sags, swells, or transients.



Voltage Configuration

Before installing luminaires, verify that the fixture model number has the correct voltage configuration for your application. See fixture specification sheet for acceptable branch circuit voltage. Failure to confirm proper configuration may result in injury damage to fixtures.

LUMASPORT 8 SPECIFICATION SHEET URL:

<https://www.cooperlighting.com/content/dam/cooper-lighting/brands/ephesus/spec-sheets/ephesus-lumasport-8-specsheet.pdf>



WARNING

Failure to confirm proper configuration may result in injury or fixture damage.

When circuiting power to luminaires, load balance all circuits. See fixture specification sheet for power characteristic data.

Electrical Performance Specifications

Technical Data

Product	Input Voltage Range (VAC)	Nominal Input Power (W)	Input Current (A)	Power Factor (>60% Load)	THD (>60% Load)	Inrush (A ² s)	Inrush period (ms)	Peak Inrush (A)
LS-8-320	120-277	340 (365 Max)	1.3 - 3.0 (4.0 Max)	> 0.9	< 20%	1.9	3.52	150
	347-480	340 (365 Max)	0.7 - 1.0 (1.5 Max)	> 0.9	< 20%	3.87	1.77	70
LS-8-640	120-277	680 (740 Max)	2.5 - 5.9 (8.0 Max)	> 0.9	< 20%	3.8	3.52	300
	347-480	680 (740 Max)	1.5 - 2.0 (3.0 Max)	> 0.9	< 20%	7.74	1.77	140

Note: Measured at 25°C Ambient Conditions Operating Conditions and Clearances

Operating Conditions and Clearances

Refer to the following sections for thermal, optical, and mechanical clearance requirements.

Thermal Clearances - Safe Operation

Installer shall verify there are adequate clearances around fixture to allow for proper heat dissipation and fire hazards. The luminaire produces a significant amount of heat and should not be installed in any confined space. Any combustible materials or structures that could limit the airflow around the luminaire heatsink must be at least 36in away from the luminaire (example ceiling). Mounting structures, adjacent fixtures or non-combustible materials can be within this limit.

1a Yoke Mount

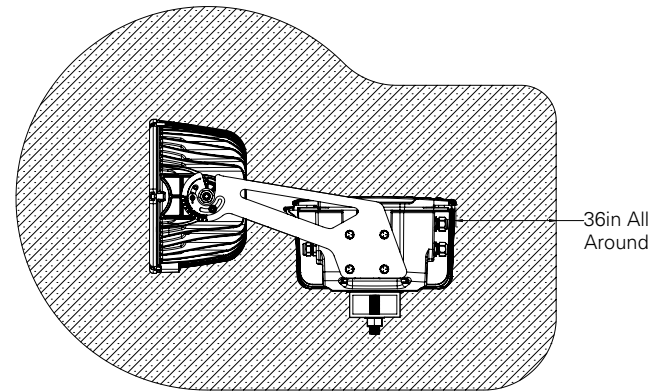

1b Pendant Mount

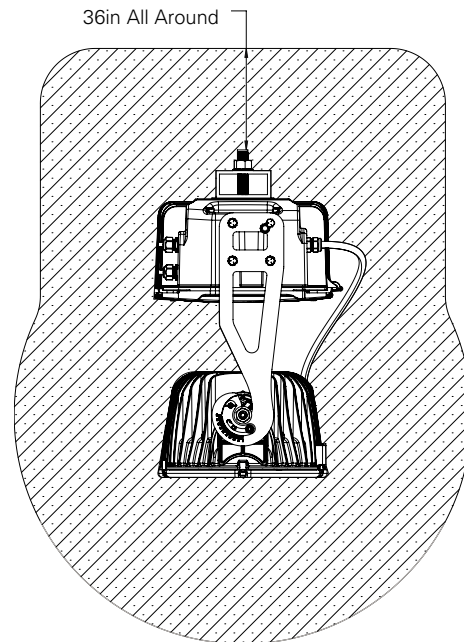

Risk of Fire. Do not install fixture within 915 mm (36 in) of any combustible material.

Optical Clearances – Maximizing Light Levels

Install fixtures according to the location and aiming data exported from photometric models to achieve desired results. However, any objects in the light path between the luminaire and the playing surface will diminish the light levels. Some examples of obstructions are building structural members, electrical panels, HVAC ductwork, banners, and scoreboards.

Before installing your lighting project, verify that there is a clear line of sight from every luminaire location to the designed aiming area, which includes not only the aiming point coordinate but also the area surrounding that aiming point. The illumination area for each fixture varies with mounting height and beam angle, but the purpose is to identify all obstructions and analyze how each will impact the light output on the playing surface, and then take corrective action as necessary to avoid the obstruction. For example, a structural beam directly in front of a luminaire will block the light from reaching the target, so in that case, the luminaire should be shifted to avoid the beam.

2a Yoke Mount

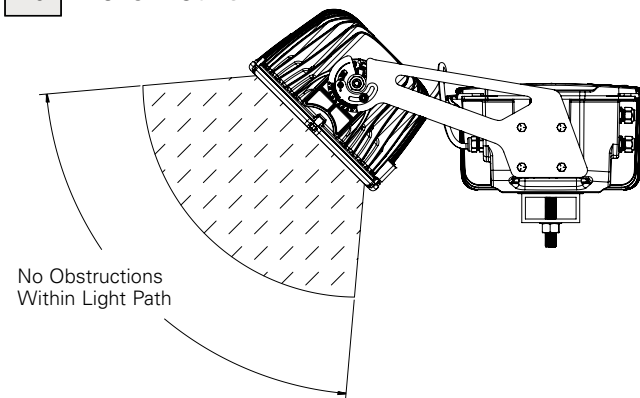

2b Pendant Mount

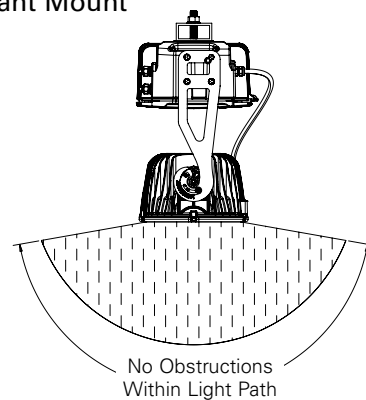

Mechanical Clearances - Avoiding Obstructions

In general, fixtures can be moved up to 5ft from the designed location without affecting photometric results as long as they are aimed at the designed aiming coordinates. For significant obstructions, photometric models should be revised with accurate obstruction dimensions to provide new fixture location and aiming data that avoids the obstruction. If options are limited, consider swapping that fixture aiming with a nearby fixture of the same type that allows clear line of sight to the aiming points. Consult your photometric designer for assistance with finding solutions to major obstructions for your project.

Proper planning will ensure the best results for your sports lighting project. Once these steps are completed, then proceed to the luminaire installation.

Operational Working Clearances

3a Yoke Mount

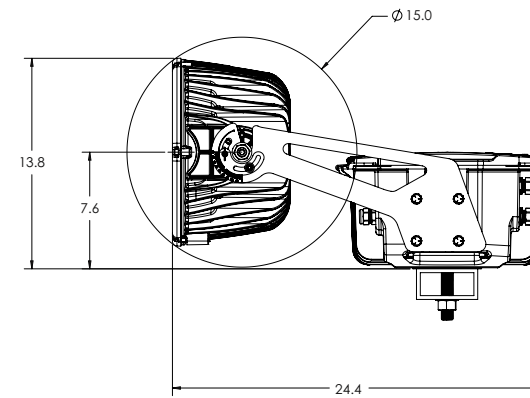

3b

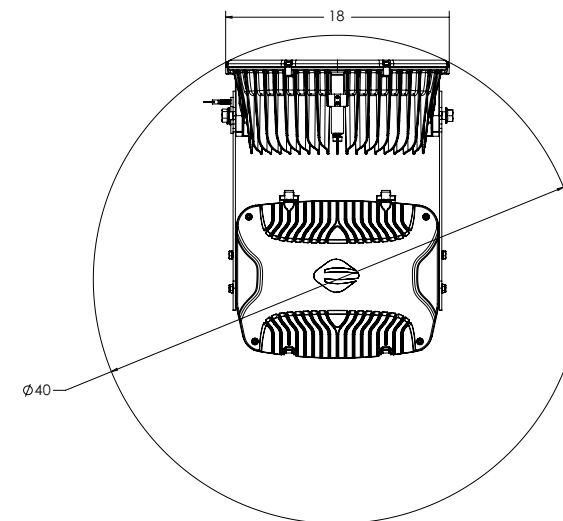

3c Yoke Mount with Visor (VHE, CV1, CV2, CV5)

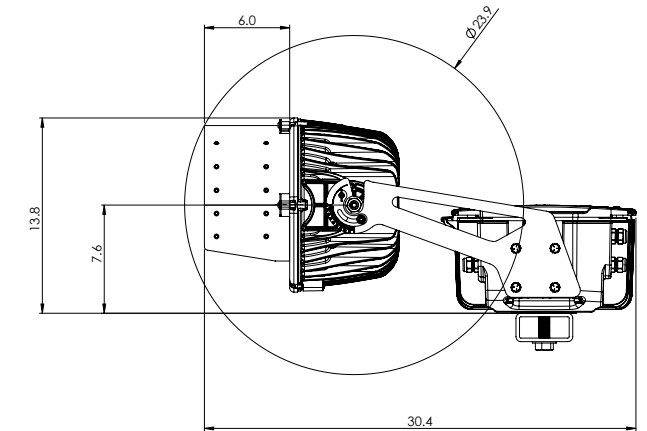

3d

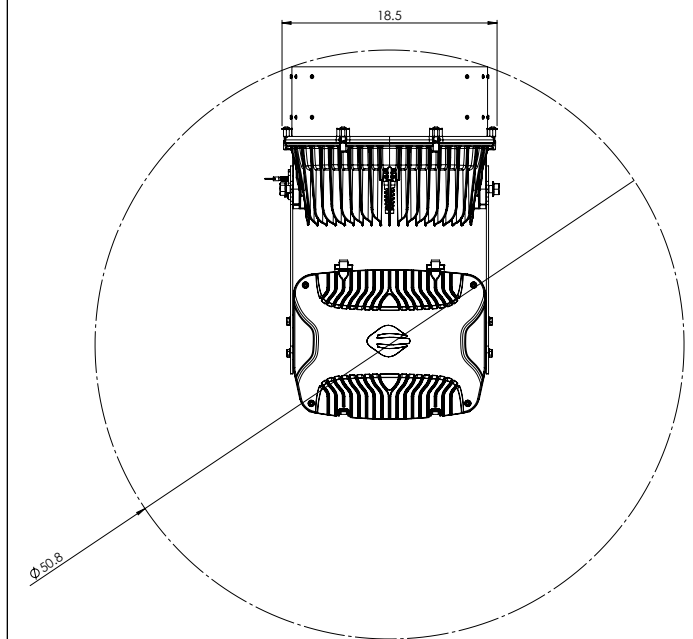

Operational working clearances

4a Pendant Mount

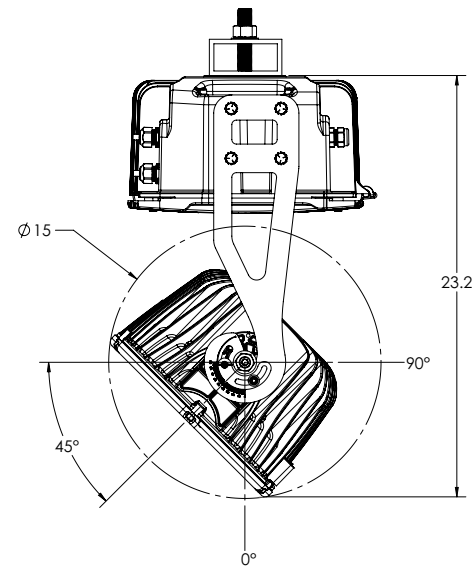

4b

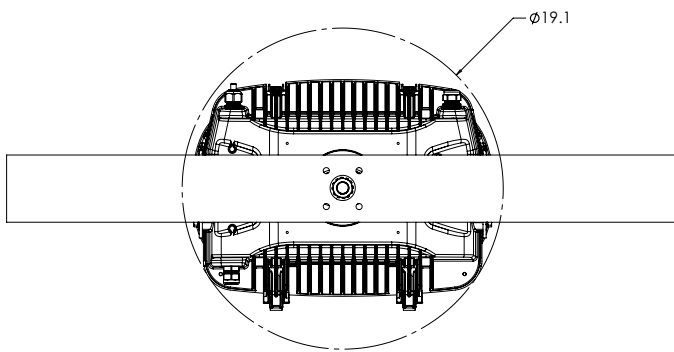

4a Pendant Mount with Visor (VHE, CV1, CV2, CV5)

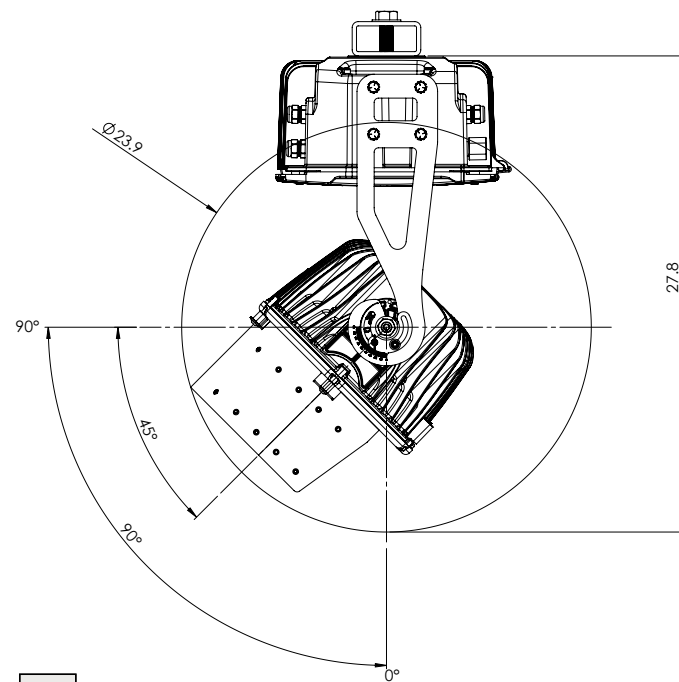

4b

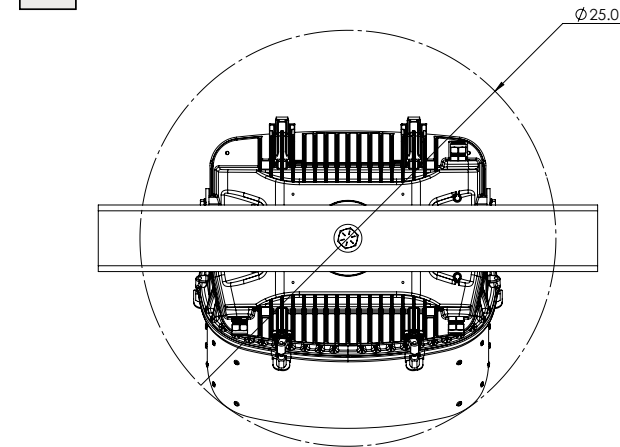

Installation Instructions

Step 1 – Prepare the luminaire



LumaSport Driver Box and Light Head must have matching power ratings. Do NOT install Light Head on a Driver Box that has a different power rating. Failure to properly match Driver Box and Light Head can damage the fixture.

Note: All fixtures that have the exact same model number are functionally identical as built from the factory.

Prepare the Driver Box

Open the Driver Box cover by unlatching the two bail latches in the back and making sure the four top screws are fully loosened.

5a

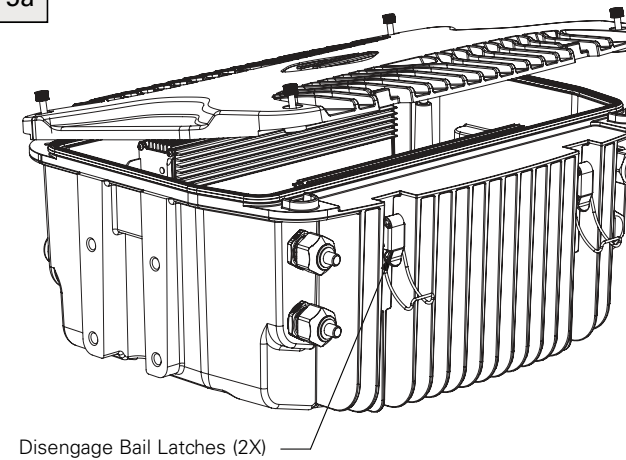

5b

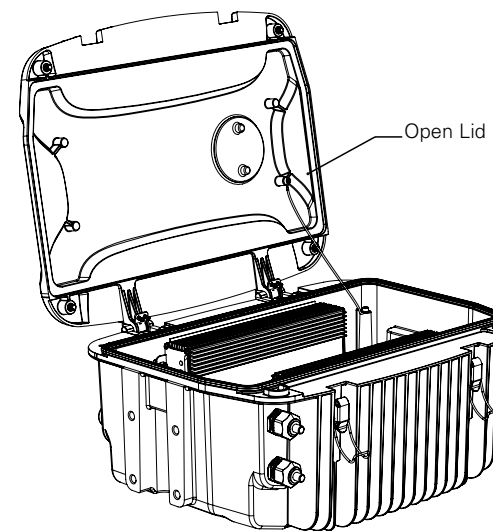

Install power cable

Always turn all fixture power sources OFF before performing any work on power or control wiring.



WARNING

Failure to disconnect all power sources may lead to damage, injury, or death.



Incoming power cable shall be SOOW style 3C cable with a minimum of 14AWG annealed stranded bare copper per ASTM B-174 with a minimum temperature range of -40°C to +90°C. Cable must be water resistant, UV rated/sunlight resistant, UL listed, and CSA certified for indoor and outdoor use. The cable jacket diameter must be within .260in - .545in.

Insert power cord through the top cord grip on the left side of the back of the Driver Box as shown in the images (6a, 6b, 6c), below.

6a Top Down View of Open Driver Box

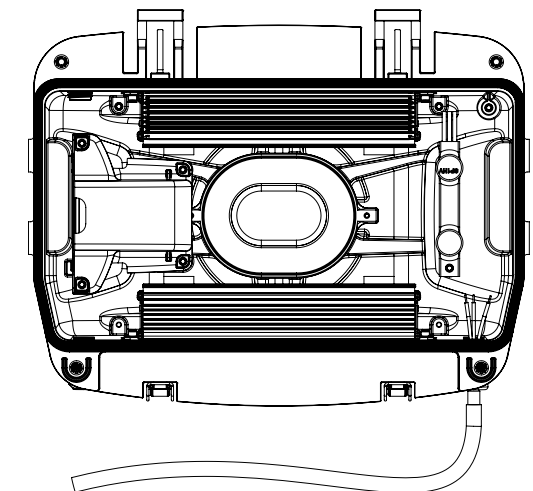

6b Closed Driver Box in Local Yoke Mount Configuration

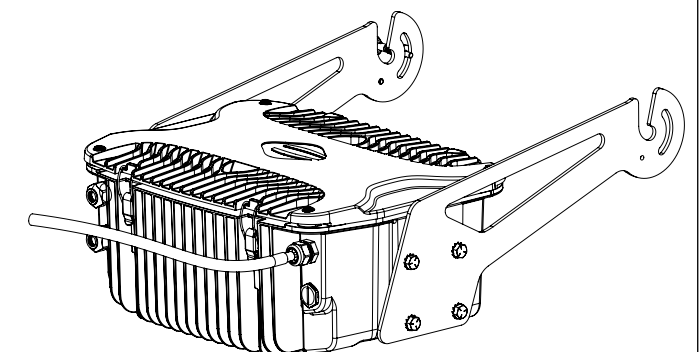



6c Local Pendant Mount

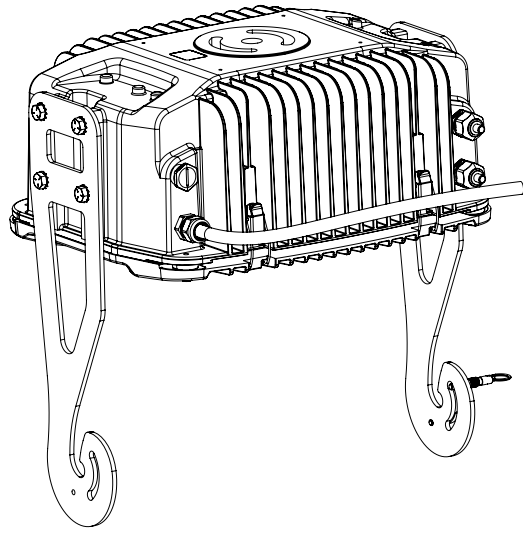

Connect incoming power cable wiring to fixture power supply wires using the Wago connectors:

Fixture Power Wire Color	Designation
Black	Line
White	Line or Neutral
Green	Ground

MAINS IN

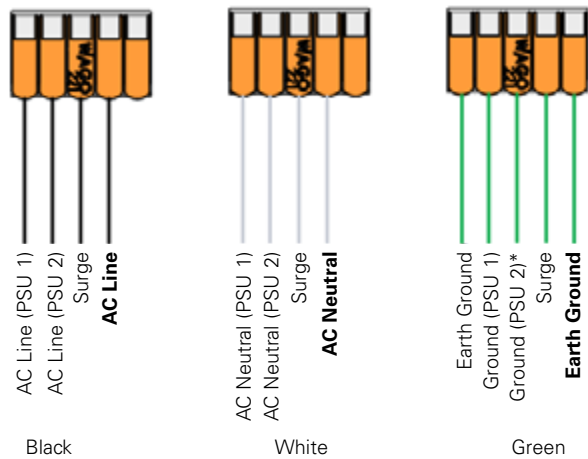

Tighten the power cable cord grip hand tight plus one full revolution using the 27mm cord grip tool to secure the cord in place so that it does not slide when pulled. Do not over-tighten the cord grip to prevent damage to the cord.

Label the Luminaire

Label each luminaire with the fixture number. Recommended label for indoor applications is white background with black lettering at least 1/2in tall. Paint markers or other methods may also be acceptable – verify with owner. Affix label to fixture Driver box or mounting bracket in a prominent location.

Note: Cooper Lighting also recommends labeling or otherwise marking the fixture number on the catwalk bracket or mounting structure to facilitate fixture identification from the catwalk or working area.



Failure to label the luminaire upon Addressing may result in improper installation and system malfunction.



Arm Prep (for Pendant Mount)

Note: Yoke mount arms are factory-assembled to the driver box.

For the pendant mount configuration, the arms are shipped separated from the driver box and they must be attached prior to installation of the light head. To install the pendant mounting arms, use the provided bolts and lock washers to secure the mounting arms to the side of the box. There are 4 bolts and lock washers for each side. Assure that the arms are positioned so the aiming graphics and quick mount orientation are in the position shown in the image below. In this configuration, the box will be inverted when mounted and the lid will open down.

7a

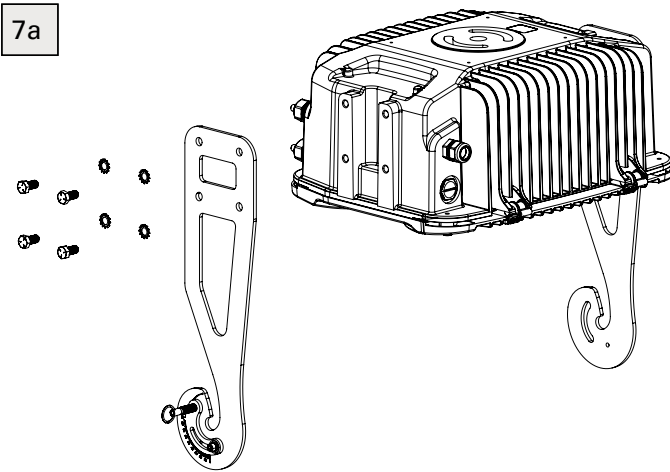

7b

Correct Installation

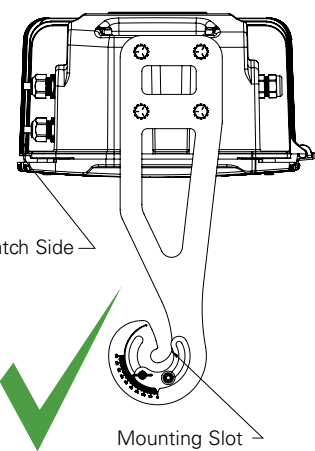

7c

Incorrect Installation

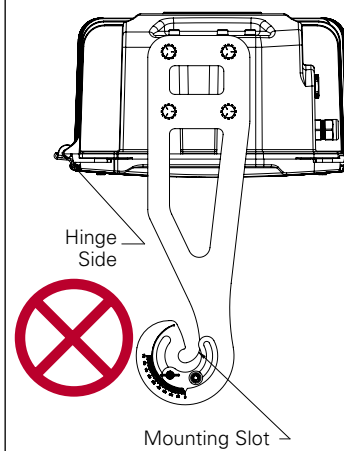

Hardware Description	Use / Location	Quantity	Torque	Tool
3/8in-16 Hex Head W/ Lock Washer	Mounting Arms to Driver Box	8X	18 ft-lb	9/16in socket



Step 2 – Install the Driver Box

Driver Box Orientation

Driver Box must be installed on a flat and level surface.



LumaSport Driver Boxes may ONLY be installed in the following physical orientations.



Yoke Mount – The Driver Box with Yoke mounting bracket must ALWAYS be with the quick mount slots and lid facing up. Do NOT install Driver Box in any other orientation. The yoke mount configuration is wet location rated.

8a

Correct Installation

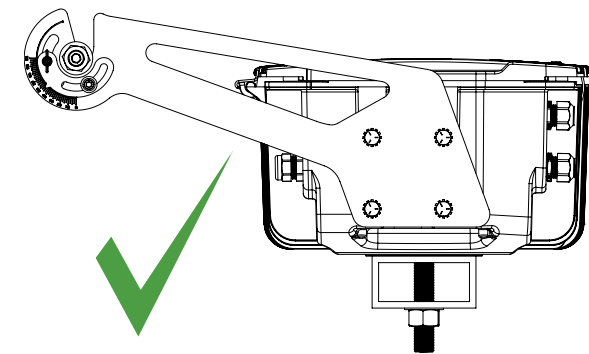

8b

Incorrect Installation

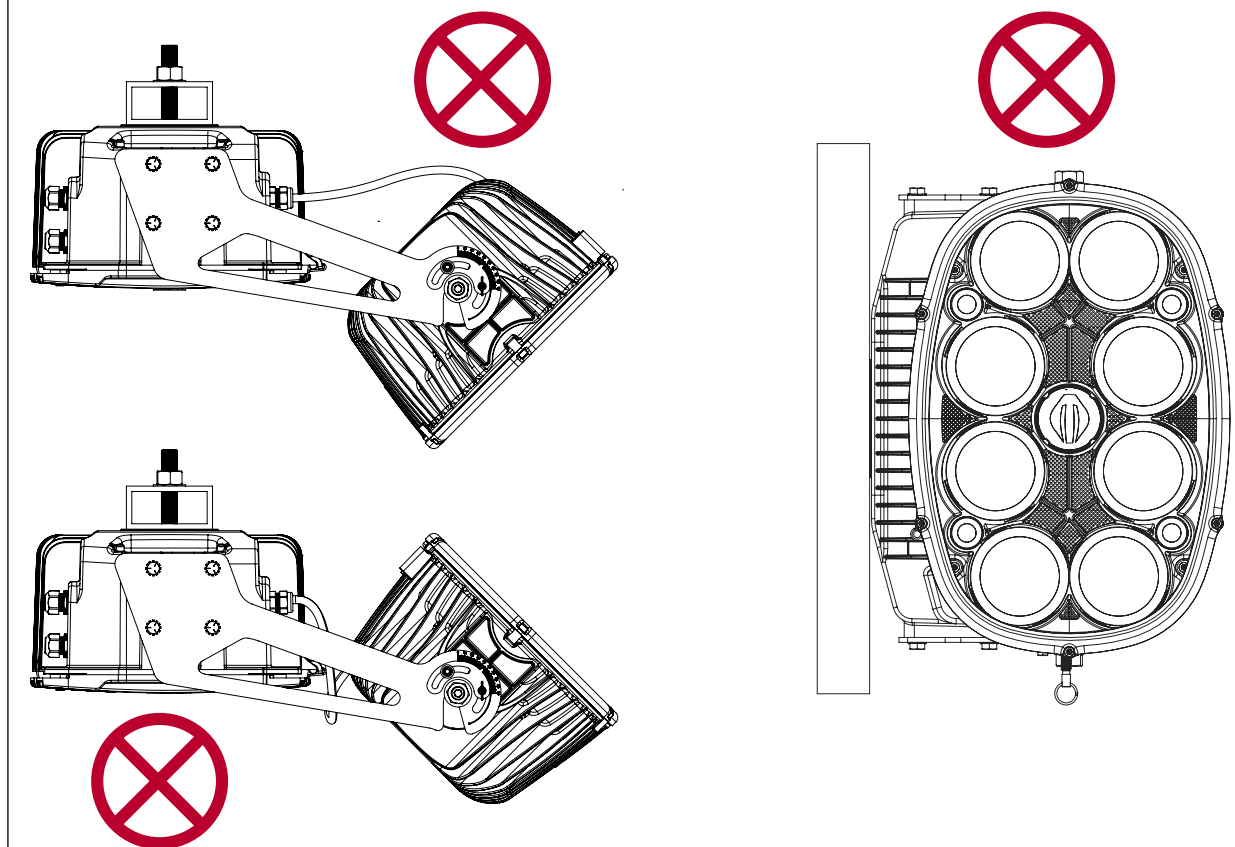



Pendant Mount – The Driver Box with pendant mounting bracket must ALWAYS be with the arm quick mount hook facing up. This will cause the lid to open down. Do NOT install Driver Box in any other orientation. The pendant mount configuration is rated for dry or damp location only and shall not be used in wet locations.



WARNING Do not install the pendant mount configuration in wet locations. Failure to install Driver Box in approved orientation or location may result in damage, injury, or death.

9a **Correct Installation**

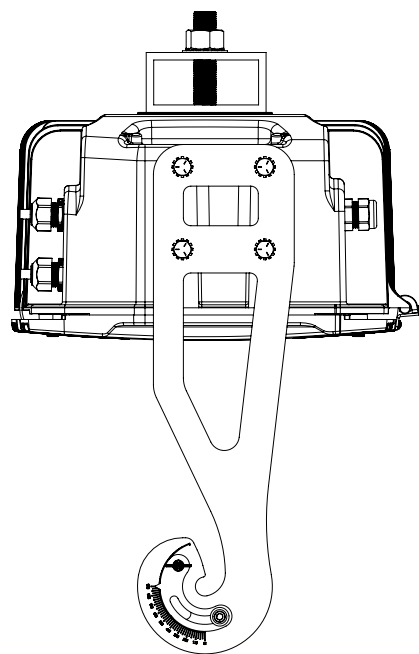

9b **Incorrect Installation**

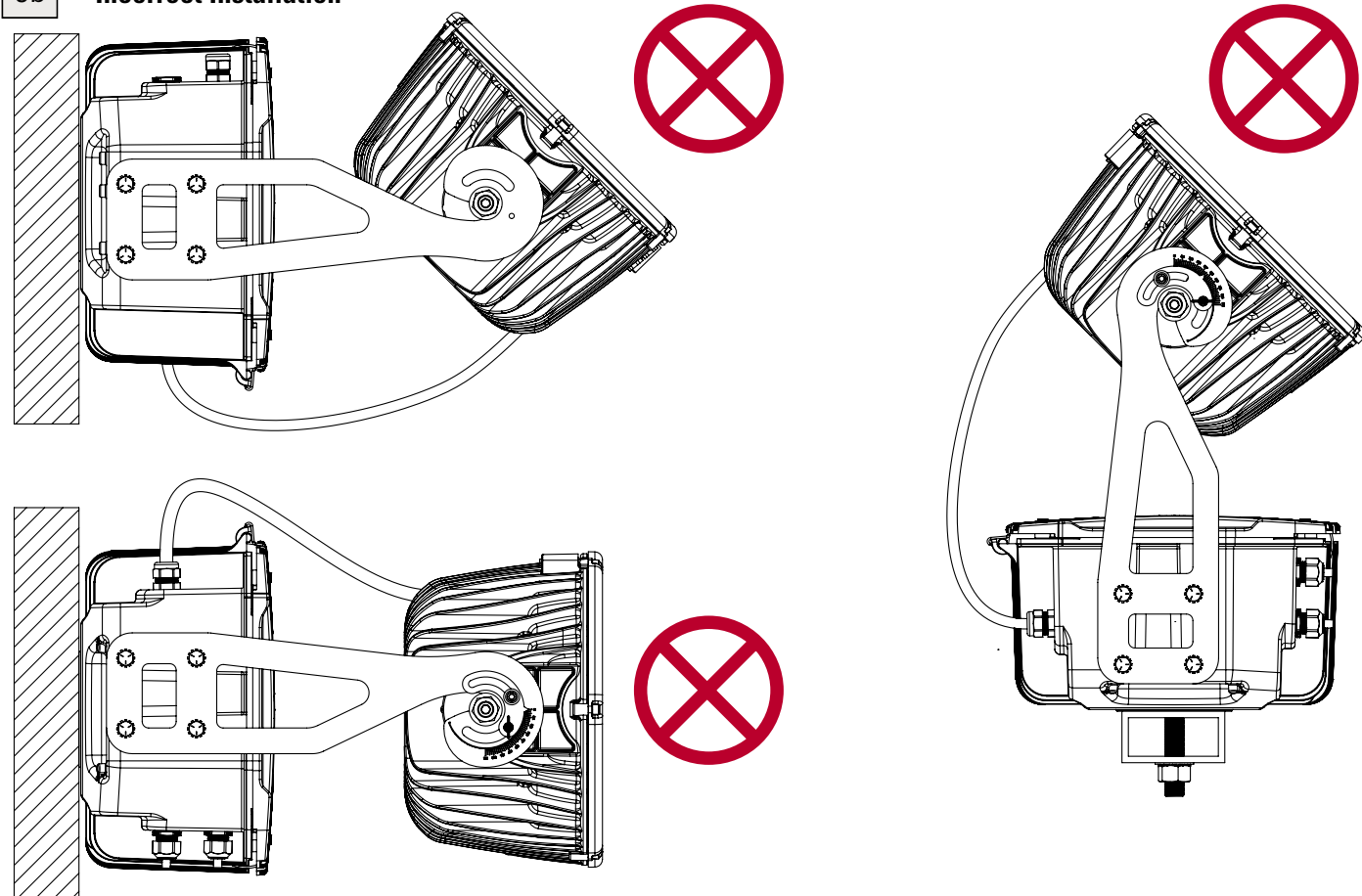

Mounting Hole Dimensions

10

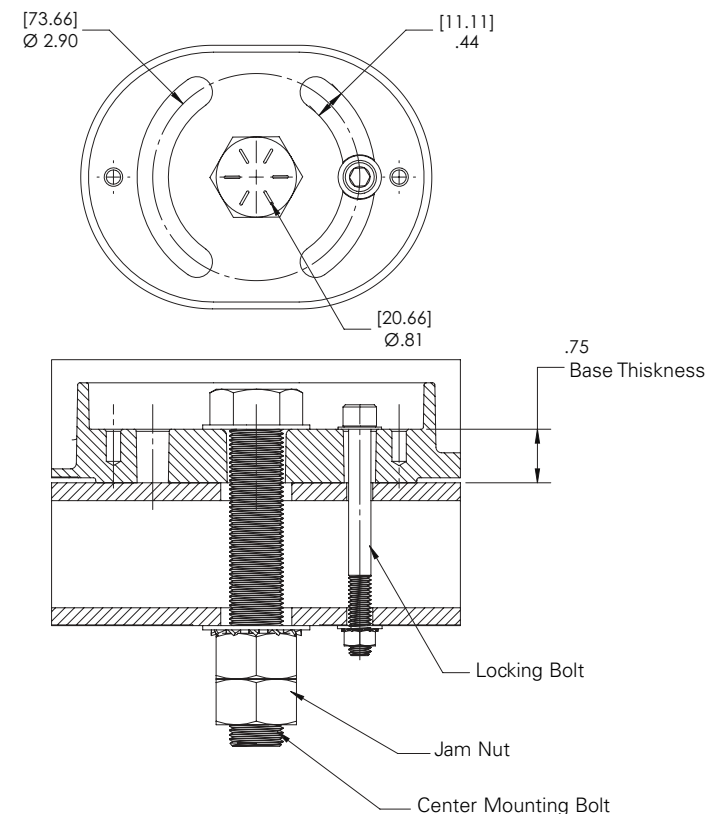

The Driver Box mounting hole is located underneath the orange cover on the base of the driver box. The central hole is sized for a 3/4in bolt and the crescent shaped features are sized for a 3/8in bolt.

Mounting Hardware (Surface Mount)

Mounting center bolt shall be 3/4in diameter corrosion resistant steel (HDG, hot dipped galvanized high-strength steel is recommended) with nut, jam nut and locking washers. A secondary 3/8in diameter corrosion resistant steel bolt with nut, flat and locking washers shall be used to lock the orient. The length of bolts is determined in the field depending upon thickness of mounting structure. Size bolts appropriately to allow secure fastening of the luminaire to the mounting structure. Tighten hardware so that fixture is secure but do not fully torque hardware until aiming is complete.

Mark the Mounting Surface (Pre-Aim Orientation)

To pre-aim the fixture orientation, draw a reference line on the mounting surface. Use a paint pen or other marker to draw a line across the center of the mounting hole, parallel and perpendicular with the crossarm or mounting structure. The crossarm should typically but not necessarily be perpendicular to the direction of the field of play. The line should extend at least 3in out from the center of the mounting hole.

11

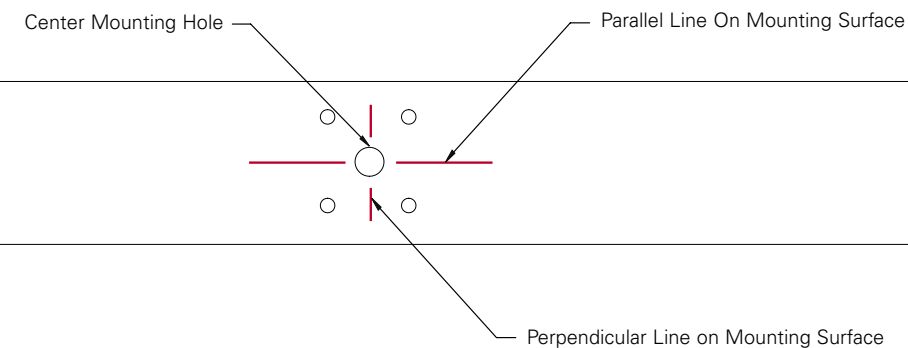



Install the Driver Box

Remove orange mounting hole cover inside Driver Box.

Set Driver Box on the mounting structure so that the center hole in the bottom of the Driver Box is aligned with the mounting hole. The mounting arms should be facing the general aiming direction. Install bolt, washers, and nut to securely fasten the box to the mounting structure.



Prevent access to area under fixture until the final torquing is complete.

Driver Box Orientation Label

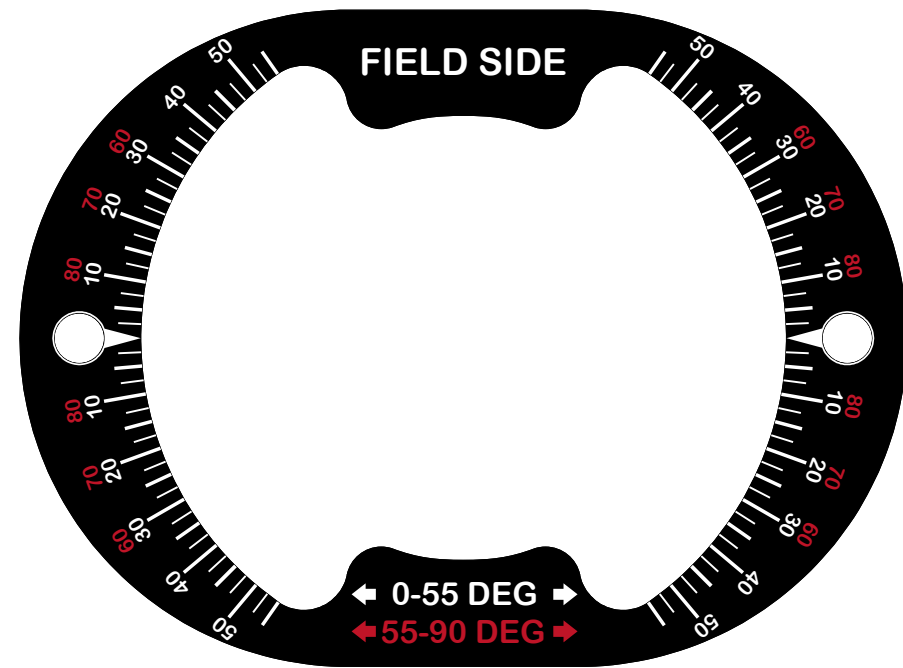

12a Local Yoke Mount

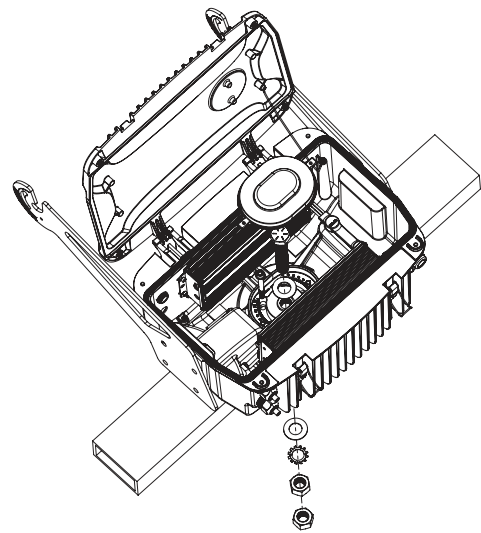

12b Local Pendant Mount

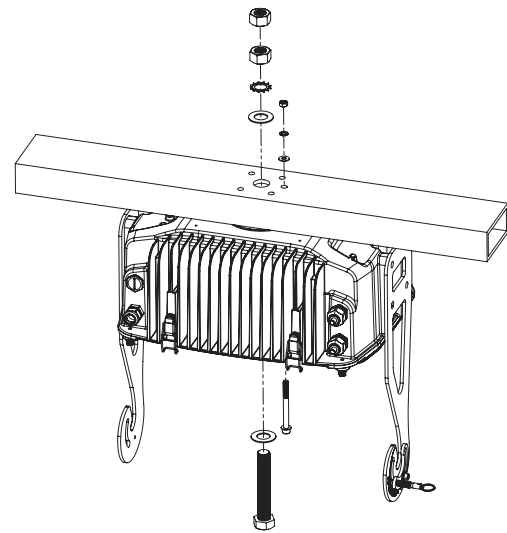

Orient the driver box (Pre-aim Orientation 0-55°)

To pre-aim the fixture orientation, rotate the Driver Box about the mounting bolt until the parallel reference line that was marked on the mounting structure is aligned with the correct angle shown in white on the orient label in the bottom of the Driver Box.

13a 90-180° Left

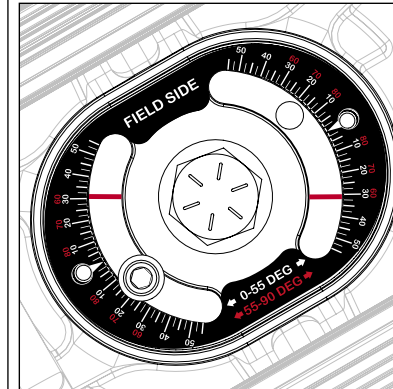

13b 90° Straight to Field

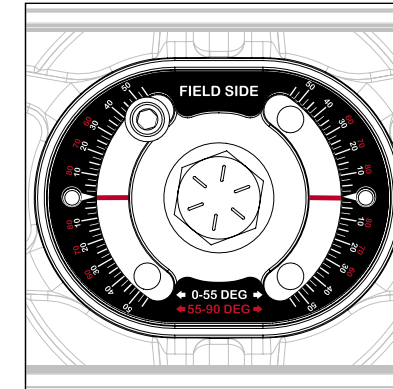

13c 0-90° Right

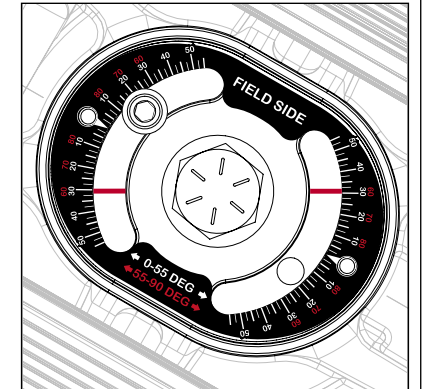

Orient the driver box (Pre-aim Orientation 55-90°)

To pre-aim the fixture orientation, rotate the Driver Box about the mounting bolt until the perpendicular reference line that was marked on the mounting structure is aligned with the correct angle shown in red on the orient label in the bottom of the Driver Box.

13a 55-90° Left

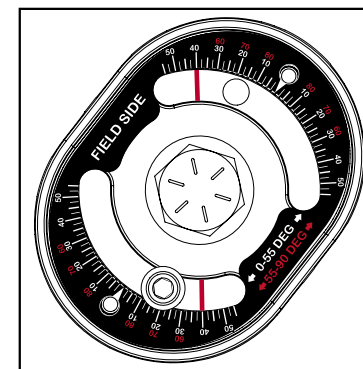

13c 55-90° Right

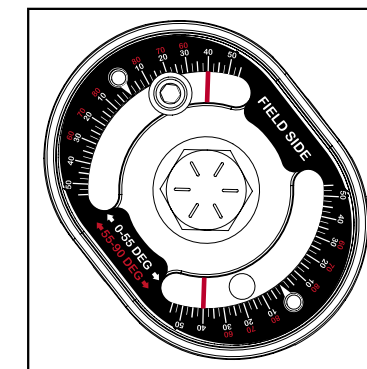

Orient the driver box (Pre-aim Orientation)

To pre-aim the fixture orientation, rotate the Driver Box about the mounting bolt until the reference line that was marked on the mounting structure is aligned with the correct angle on the orient label in the bottom of the Driver Box.

If laser aiming, tighten the mounting hardware so that fixture is secure but do not fully torque hardware until final aiming is complete.



If using the orient gauge, torque the mounting hardware at this step to the values in the table below. If you are laser aiming, torque the hardware to the specification once the fixture is aimed.

Hardware Description	Use / Location	Tool	After Aiming Torque	Quantity
3/4in Mounting Bolt Assembly	Mounting Fixture To Mounting Structure	1-1/8in Socket	80 ft-lb	1X
3/8in-16 Locking Bolt Assembly	Orient Lock	9/16in Socket	20 ft-lb	1X

Mounting Accessories

Diving Board Kit
 Diving Board is intended to only to mount to 2in x 4in steel cross arms. Designed to be used with the LUMASPORT 8 and LUMASPORT 16 luminaires only. Do not use in unapproved luminaires or mounting applications.

WARNING

-  Diving Board may ONLY be installed in the following physical orientations. Failure to install the Diving Board Kit in approved orientation or location may result in damage, injury, or death. (Reference diagram DB4a and DB4b)
-  Prevent access to area under fixture until the final torquing is complete.

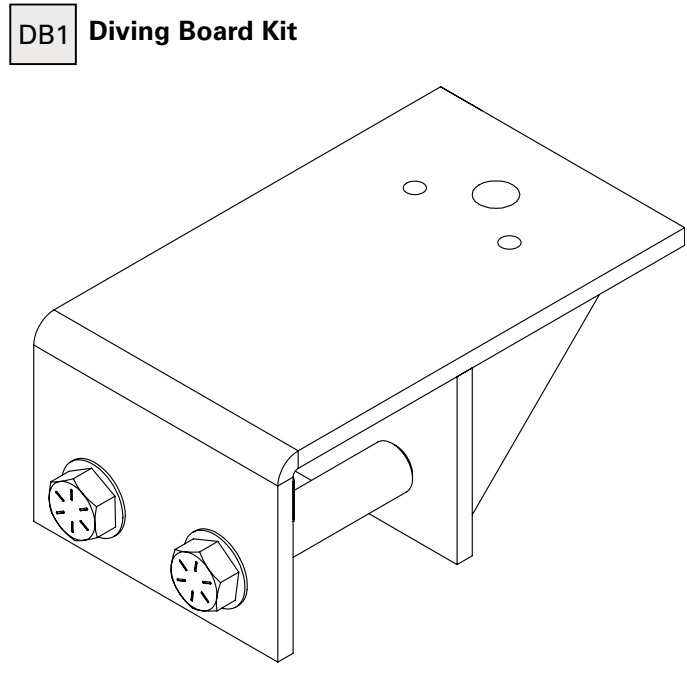

DB2 Diving Board Kit Parts Diagram

Item #	Description	Quantity
1	Diving Board Bracket	1
2	Bolt Sleeve	2
3	3/4in-10 X 6in Structural Hex Bolt, Hot Dip Galvanized	2
4	3/4in Steel Flat Washer, Hot Dip Galvanized	2
5	3/4in Ext Tooth Washer, Steel, Magni-565 Grey Polycoat	2
6	3/4in-10 Structural Steel Hex Nut, Hot Dip Galvanized	2
7	Stainless Shim	1

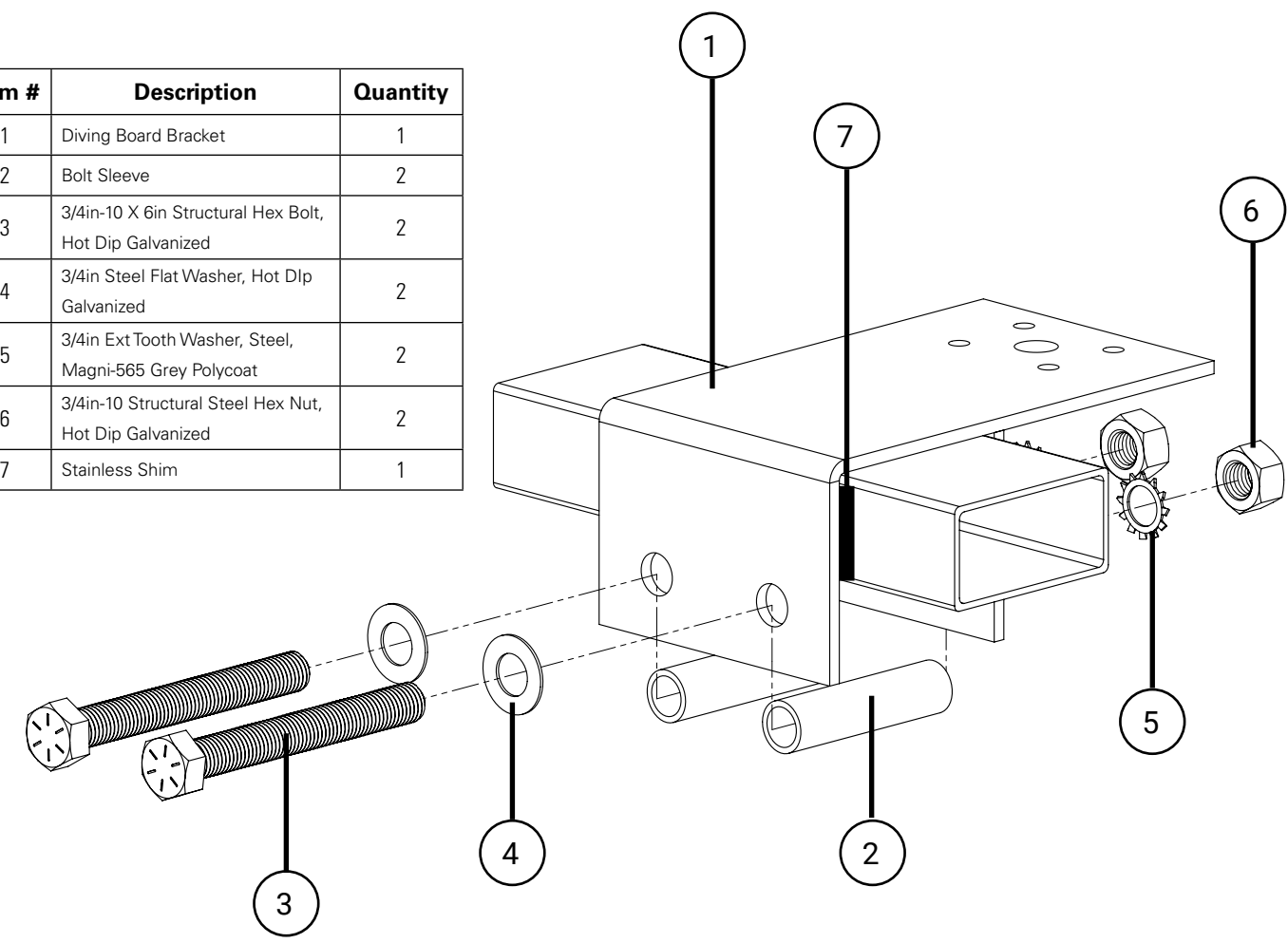

Diving Board Kit (DVGBRD) Hardware

Hardware Description	Use / Location	Tool	After Aiming Torque
3/4in-10 X 6in Structural Hex Bolt, Hot Dip Galvanized	Diving Board is intended to only to mount to 2in x 4in steel cross arms.	<ul style="list-style-type: none"> • 1 1/8in Socket & Ratchet • 9/16in Socket & Ratchet • Adjustable Crescent Wrench • Adjustable Torque Wrench 	120ft-lb.

Additional (HRDM34) Mounting Fastener Hardware Kits

Hardware Description	Use / Location	Tools	After Aiming Torque
HRDM34-025	Additional mounting fastener hardware kit needed to attach a fixture to the DVGBRD = Diving Board	<ul style="list-style-type: none"> • 1 1/8in Socket & Ratchet • 9/16in Socket & Ratchet • Adjustable Crescent Wrench • Adjustable Torque Wrench 	80ft-lb
HRDM34-075	.50-.75in clamping thickness, flat surfaces drilled for 3/4in hardware		
HRDM34-200	2.00in clamping thickness, use for 2in x 4in Cross arms that are drilled for 3/4in hardware		

Steps to Install

1. The Diving Board is mounted on top of the cross arm with bolts and sleeves mounted underneath to clamp the bracket to the crossarm and secure it. (Refer to the Diving Board Parts Diagram) Only mount it as shown
2. Hold Diving Board Bracket (item 1) on top of cross arm.
3. Optional: Place provided shim between side of bracket and cross arm if there is excessive clearance
4. Insert both Clamping Hex Bolts through Washer, Bracket, Bolt Sleeve, other side of Bracket, Lock Washer, and Hex Nut.
5. Torque 3/4in-10 X 6in Structural Hex Bolts: 120ft-lb.
6. Hold Fixture on top surface
7. Use hardware kit HRDM34-025 for mounting fixture to bracket. Insert 3/4in Fixture mounting bolt through Flat washer, fixture, and primary mounting hole on Diving Board, Flat Washer, Lock Washer, and Hex Nut
8. Use hardware kit HRDM34-025 for mounting fixture to bracket. Insert 3/8in secondary mounting bolt through Flat washer, fixture, and any secondary mounting hole on Diving Board, Flat Washer, Lock Washer, and Hex Nut
9. Torque fixture bolts:
 - A. Primary fixture 3/4in bolt torque: 80ft-lb.
 - B. Secondary fixture 3/8in bolt torque: 20ft-lb.

DB3 Diving Board Kit (DVGBRD) with Additional (HRDM34) Mounting Fastener Hardware Kit

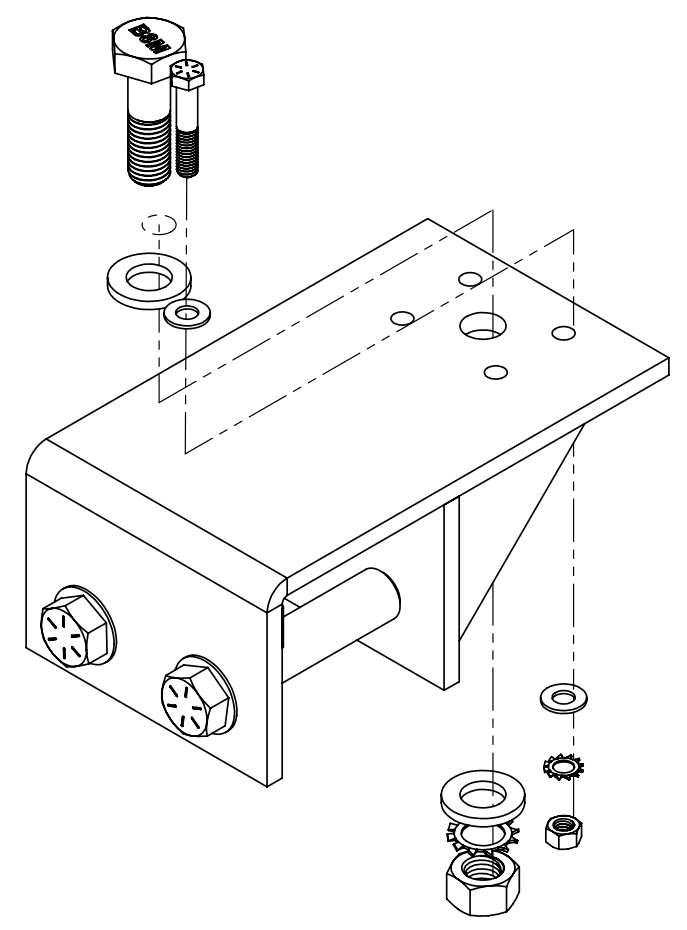

DB4a **Correct Installation**

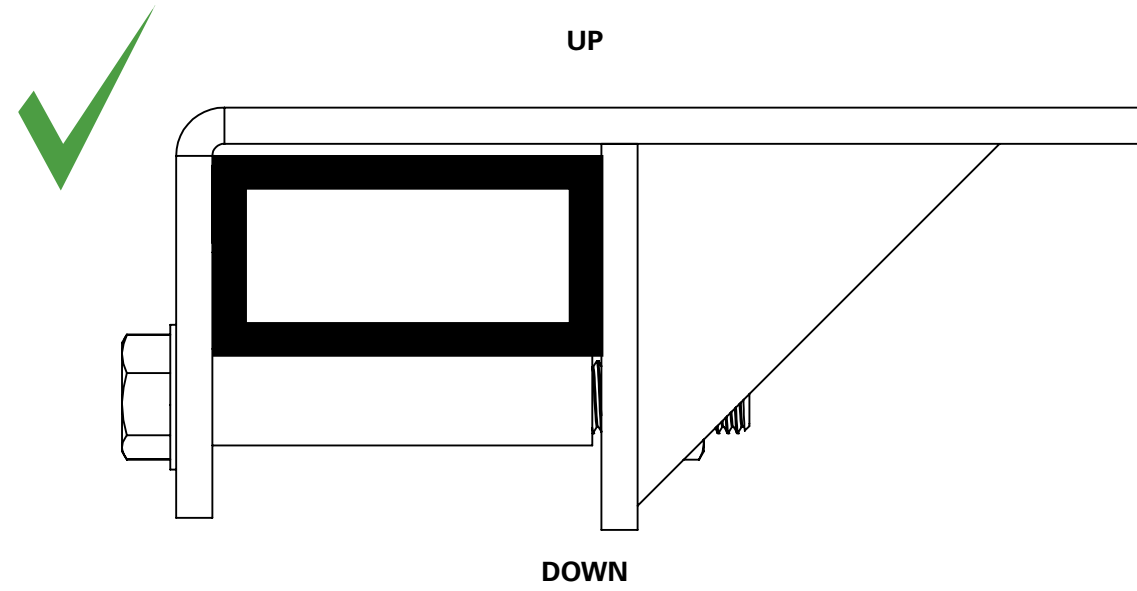

DB4b **Incorrect Installation**

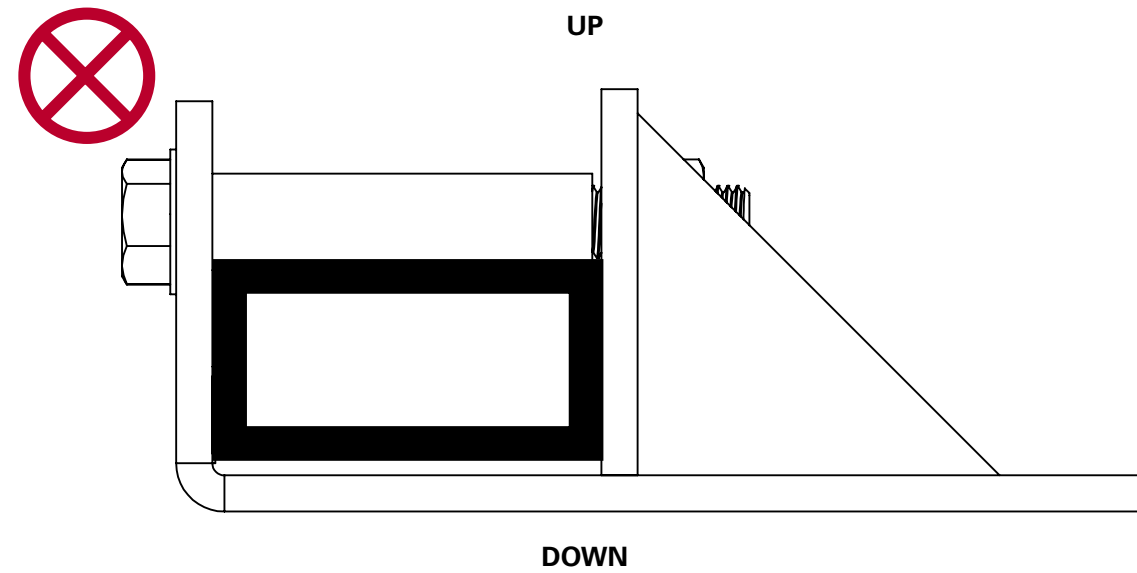

 **Mounting Accessories**

Extension Plate Kit (EXTPLT)

Extension Plate Kit to mount to structures .25in, .5in, or 2.00in thick. Designed to be used with the LUMASPORT 8, LUMADAPT 8 & PRISM RGBA luminaires only.

WARNING



Extension Plate may ONLY be installed in the following physical orientations. Failure to install the Extension Plate Kit in approved orientation or location may result in damage, injury, or death. (Reference diagram EP5a and EP5b)



Prevent access to area under fixture until the final torquing is complete.

EP1

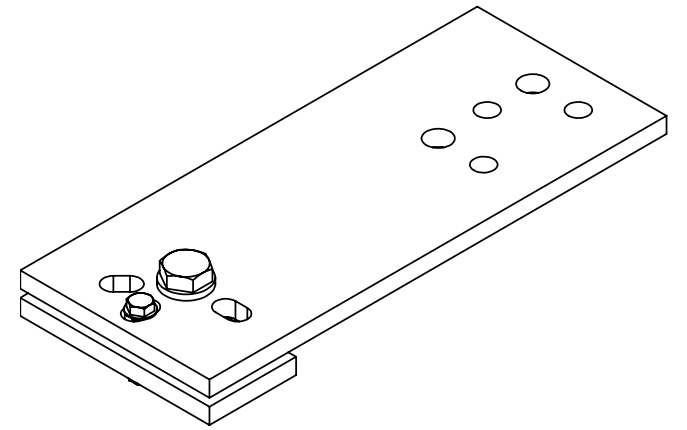

Extension Plate Kit Parts Diagram

Item #	Description	Quantity
1	Extension Plate	1
2	Washer Plate	1
3	5/8in Hex Bolt	1
4	5/8in Washer	2
5	5/8in-11 Hex Nut	1
6	5/8in Split Washer	1
7	3/8in Washer	2
8	3/8in Hex Bolt	1
9	3/8in Split Washer	1
10	3/8in-16 Hex Nut	1

EP2

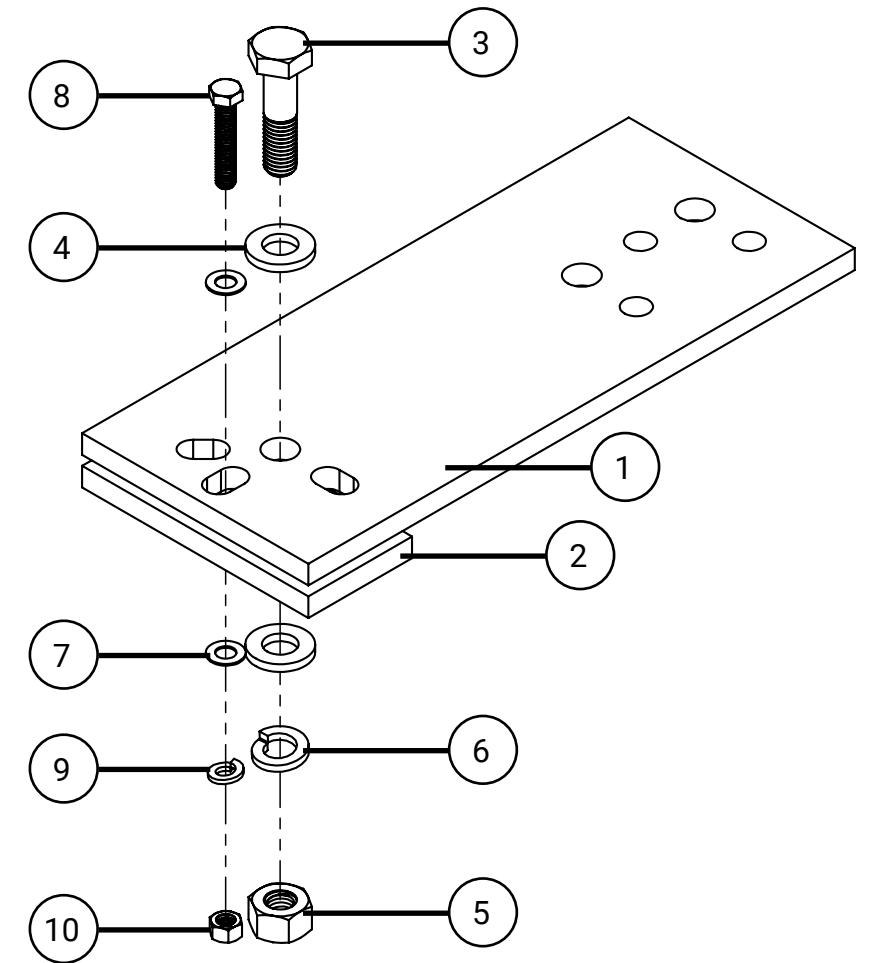

Extension Plate Kit (EXTPLT) Hardware

Hardware Description	Use / Location	Tools	After Aiming Torque
EPH-EXTPLT-025	Extension Plate Kit 5/8in-11 primary and 3/8in-16 secondary fastening hardware to mount to structures .25in thick. Designed to be used with the LUMASPORT 8, LUMADAPT 8 & PRISM RGBA luminaires only.	<ul style="list-style-type: none"> 15/16in Socket & Ratchet 9/16in Socket & Ratchet Adjustable Crescent Wrench Adjustable Torque Wrench 	Primary 80ft-lb Secondary 20ft-lb
EPH-EXTPLT-050	Extension Plate Kit 5/8in-11 primary and 3/8in-16 secondary fastening hardware to mount to structures .5in thick. Designed to be used with the LUMASPORT 8, LUMADAPT 8 & PRISM RGBA luminaires only.		
EPH-EXTPLT-200	Extension Plate Kit 5/8in-11 primary and 3/8in-16 secondary fastening hardware to mount to structures 2.00in thick. Designed to be used with the LUMASPORT 8, LUMADAPT 8 & PRISM RGBA luminaires only.		

Additional (HRDM58) Mounting Fastener Hardware Kits

Hardware Description	Use / Location	Tools	After Aiming Torque
HRDM58-050	.375-.500in clamping thickness, Use for Extension Plate (EXTPLT) or other flat surfaces drilled for 5/8in hardware	<ul style="list-style-type: none"> 15/16in Socket & Ratchet 9/16in Socket & Ratchet Adjustable Crescent Wrench Adjustable Torque Wrench 	Primary 80ft-lb Secondary 20ft-lb
HRDM58-200	2.0in clamping thickness, Use for Extension Plate (EXTPLT) or other flat surfaces drilled for 5/8in hardware		

Extension Plate Kit Mounting Diagram

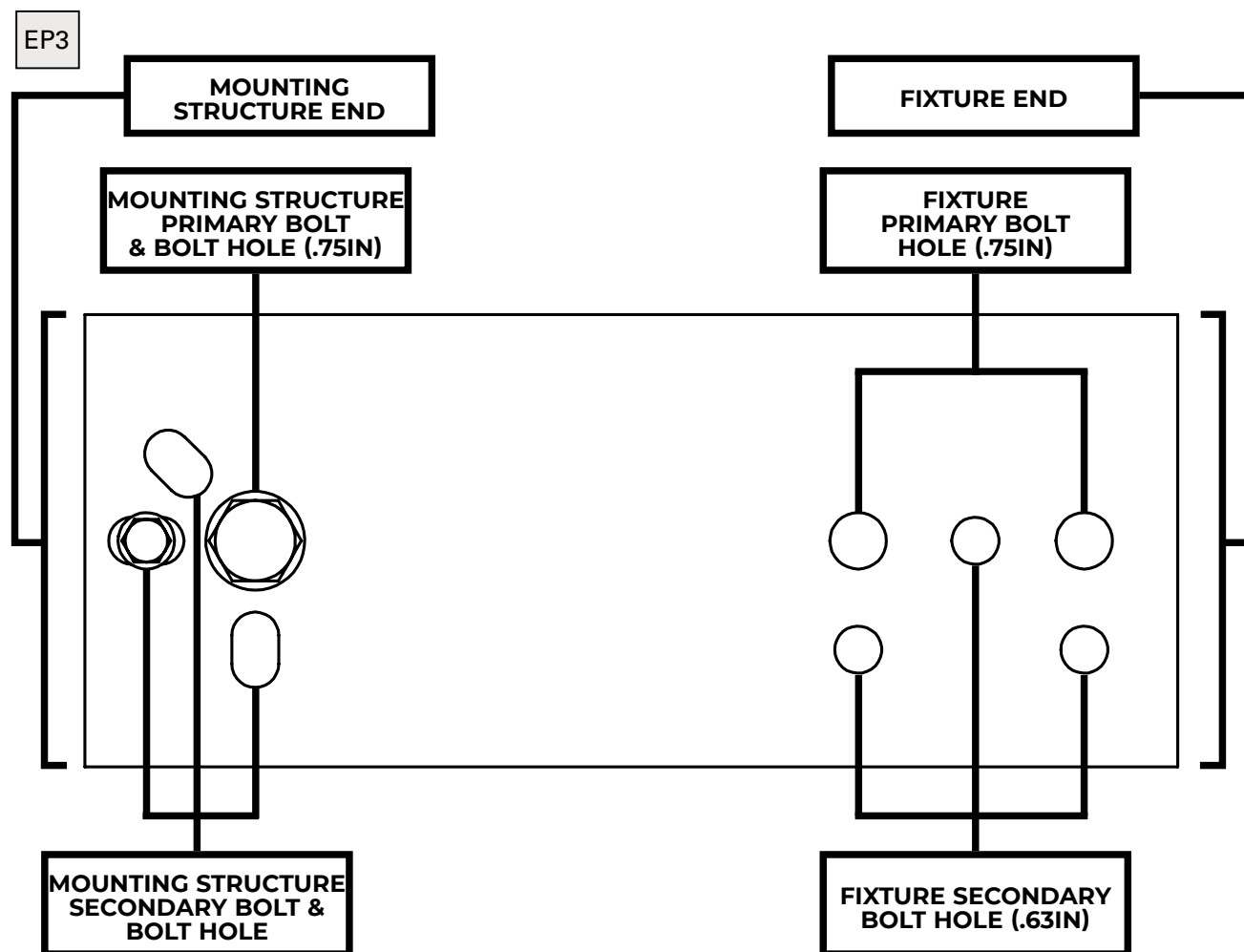

Steps to Install

1. Test fit the extension plate on a mounting structure using the method described below to verify no modifications to the structure are required. If additional holes or other structural changes are required, these must be approved by in a qualified structural review.
2. Hold extension plate on top of mounting structure and washer plate below mounting structure so that primary and secondary bolt holes align through the mounting structure.
3. Install primary bolt, washers, and nut through primary mounting structure holes as shown to secure extension plate and washer plate to structure and tighten securely.
4. Install secondary bolt through one of the three secondary mounting structure holes and tighten securely.
5. Torque mounting structure bolts:
 - a. Primary mounting structure bolt torque: 80ft-lb
 - b. Secondary mounting structure bolt torque: 20ft-lb
6. Draw pre-aim orient line on fixture end of extension plate if desired. See fixture installation manual for more information.
7. Set fixture driver box on top of fixture end of extension plate so that fixture primary bolt hole aligns with driver box primary bolt hole. NEVER install fixture driver box underneath extension plate.
8. Install fixture primary bolt, washers, and nut as shown to secure fixture to extension plate.
9. Orient fixture driver box as necessary for rough aiming. See fixture installation manual for more information.
10. Install fixture secondary bolt through one of the three fixture secondary bolt holes and tighten securely.
11. Torque fixture bolts:
 - a. Primary fixture bolt torque: 80ft-lb
 - b. Secondary fixture bolt torque: 20ft-lb

Extension Plate Kit (EXTPLT) with Additional (HRDM58) Mounting Fastener Hardware Kit

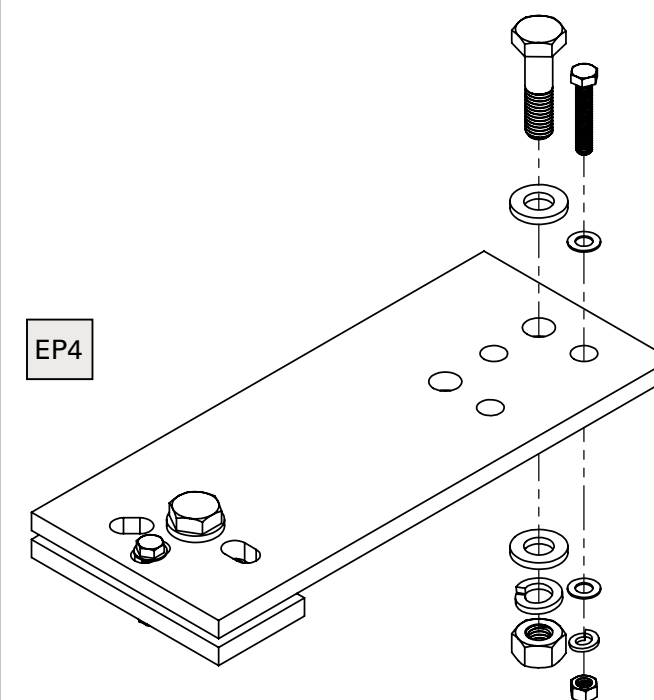

EP5a

Correct Installation

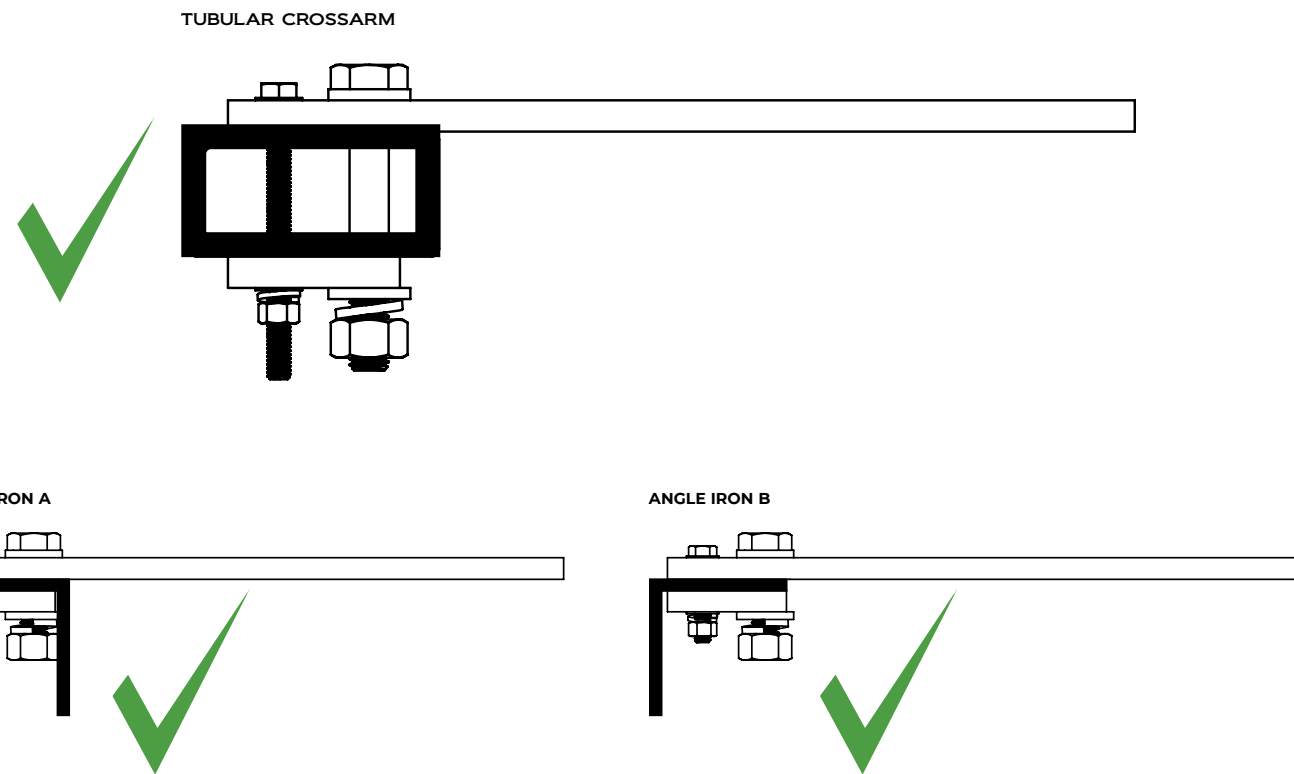

EP5b

Incorrect Installation

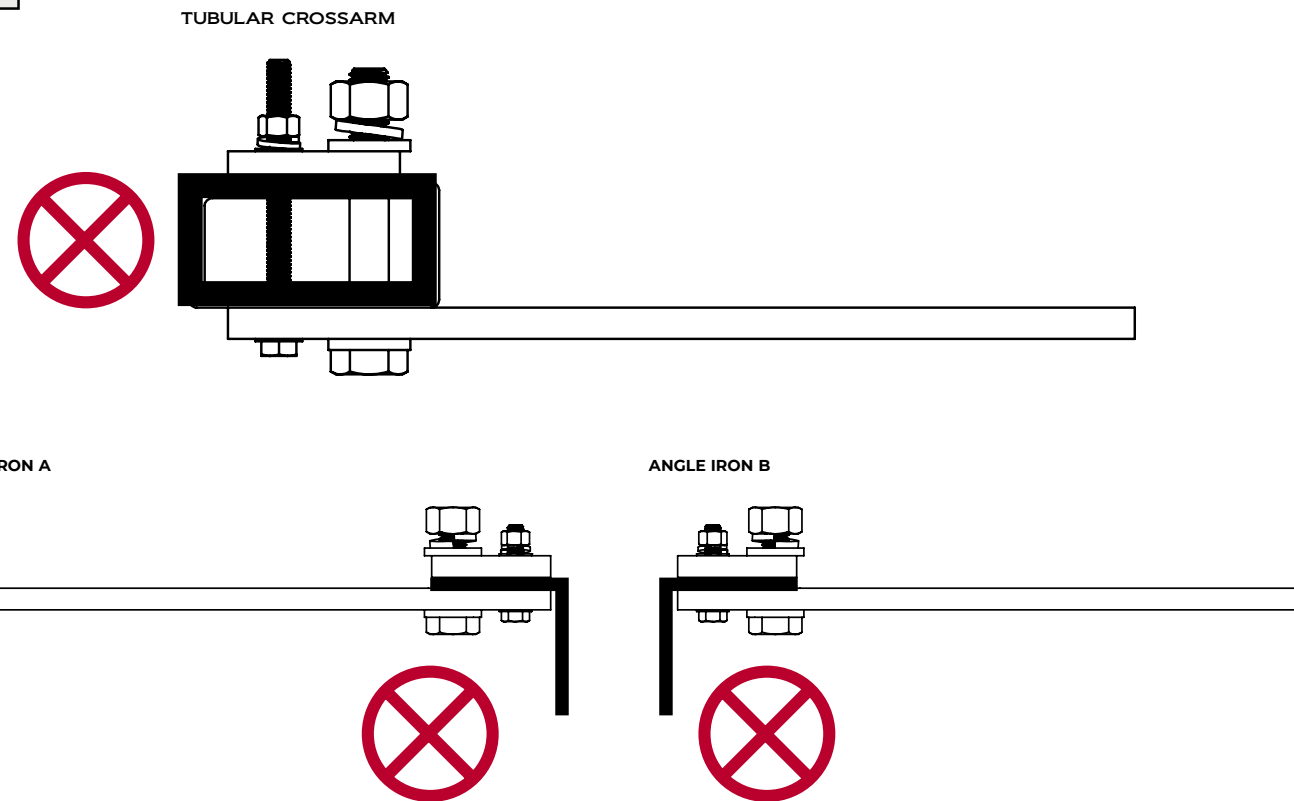

Install Control Cables (Wired DMX Configurations)

Note: For wireless applications, skip to Record MAC Address section.

Control Standards: All control work shall conform to ANSI E1.11 – 2008 (r2013), USITT DMX512-A, Asynchronous Serial Digital Data Transmission Standard for Controlling Lighting Equipment and Accessories. At a minimum, DMX cable shall be 1-pair (24AWG, 7x32 Stranding) Twisted (minimum of 4.8 twists/foot), Shielded, minimum of 100 ohms impedance, and <25pF/ft. Capacitance.

Install control cables through the cord grips on the back right side of the Driver Box.

Ephesus follows the guidelines established for DMX connection and transmission as outlined in ANSI standard E1.11 – 2004 Entertainment Technology - USITT DMX512-A — Asynchronous Serial Digital Data Transmission Standard for Controlling Lighting Equipment and Accessories

This includes placement of a resistor matching the nominal impedance of the DMX conductors after the last fixture in the DMX run.

For more information about the DMX standard, visit:

https://tsp.esta.org/tsp/documents/docs/ANSI-ESTA-E1-11_2008R2018.pdf

14a

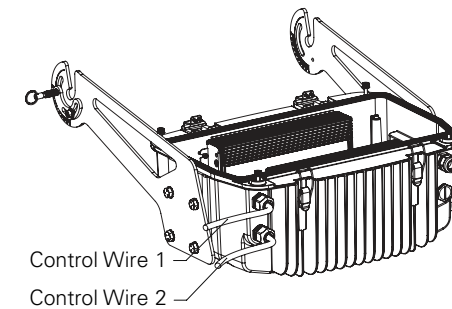

14b

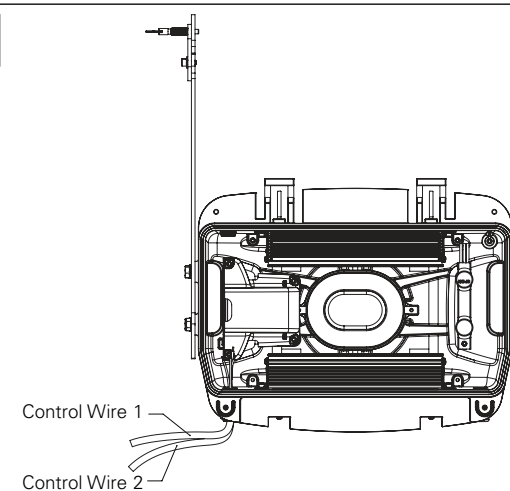

Connect to fixture control wires as follows:

	Fixture DMX Control Wire Color	Designation
Input	Grey	DMX -
	Purple	DMX +
	Black	Shield
Output	Grey	DMX -
	Purple	DMX +
	Black	Shield

DMX IN

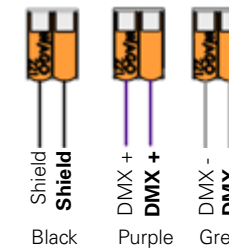

DMX OUT

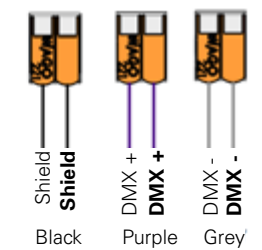

Tighten power cable cord grip hand tight plus one full revolution using the 24mm cord grip tool to secure the cord in place. The cord shall not slide when pulled. Do not overtighten the cord grip to prevent damage to the grip and cord.



Record MAC Address (Wireless AirMesh Configurations)

Note: No control cables are required for wireless applications.

For wireless applications, every fixture also has a unique MAC address. It is important to record that MAC address for each fixture with the corresponding fixture number to ensure the control system programmers can identify each fixture.

Every fixture that has wireless control capability will have a sticker inside the driver box that has the MAC address of the wireless control card that was installed in that fixture. Remove the sticker from the inside of the driver box and place it on the MAC address recording sheet. If you do not have a MAC address recording sheet, simply affix the sticker to a piece of paper and write the fixture number next to the sticker. Keep all MAC address stickers in a safe location and provide them to the Controls Technician.

Step 3 – Install the Light Head

Set pre-aiming tilt angle

The Light head tilt angle can be rough-aimed using the guide on the left mounting arm. Retract spring plunger by pulling the clip and rotating it into the locking position. Loosen the tilt lock screw slightly to allow the aiming plate to rotate.



Do NOT over-loosen or remove tilt lock screw. Prevent access to area under fixture until the final torquing is complete.

15

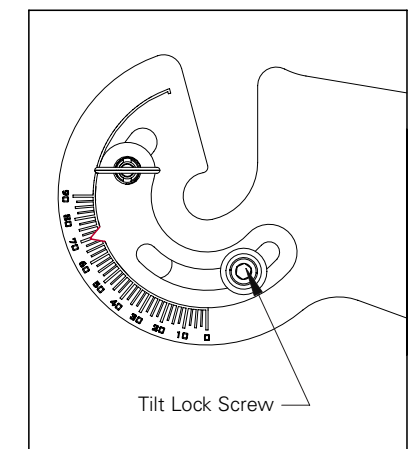

Note: Example shown at 70° tilt. Minimum tilt of 15* when using a wireless configuration.



16a Spring Plunger Disengaged

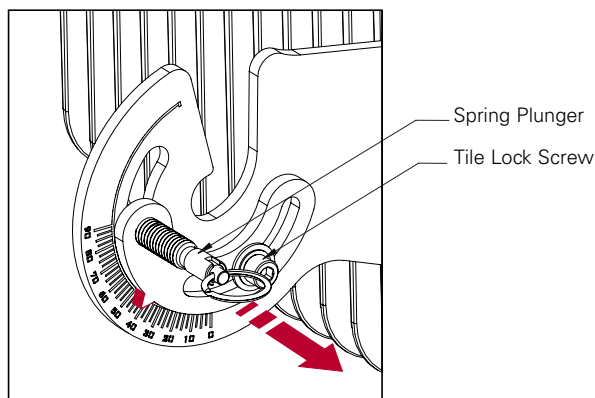

16b Spring Plunger Engaged

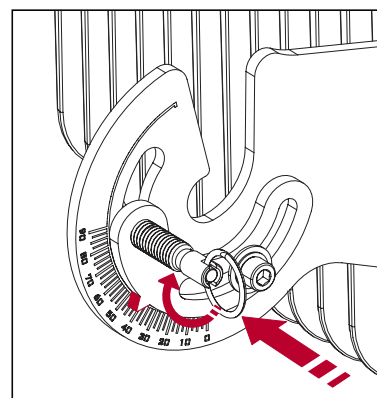

Rotate the labeled aiming plate until the arrow is over the desired tilt angle. Hold the aiming plate in place and tighten the tilt lock screw.

If laser aiming, tighten the tilt lock screw so that fixture is secure but do not fully torque hardware until final aiming is complete.

If using the tilt gage, torque the tilt lock screw to:

Hardware Description	Use / Location	Tool	After Aiming Torque	Quantity
1/4in-20 Screw	Tilt Lock	3/16in Allen	75 in lb	1X



Prevent access to area under fixture until the final torquing is complete.



Install the Light Head

Be careful of AirMesh module (wireless configurations) when installing Light head. Do not damage module. Install the Light head with the screw-in vents on the bottom and toward the driver box. The Laser Aiming Pin feature should be on the top. Set the Light head in place so that the side mounting bolts drop into the notches in the mounting arms.

Yoke Mount

17a

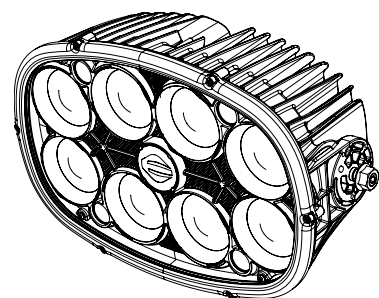

17b

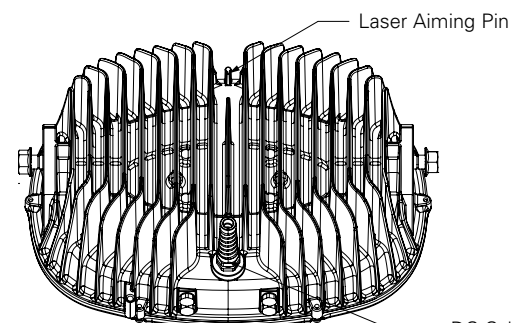

17c

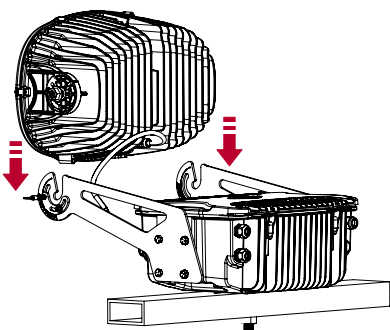

17d

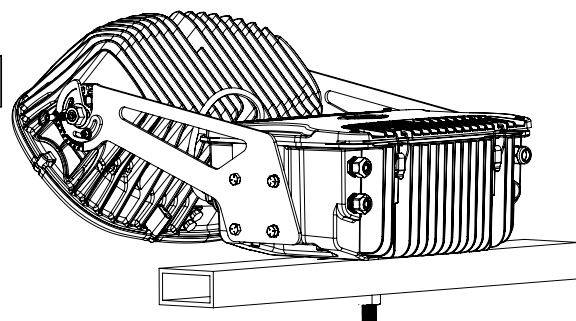

Pendant Mount

Rotate the Light head to the approximate tilt angle and release the spring plunger. The plunger will engage when the light head is at the correct tilt angle.

18a

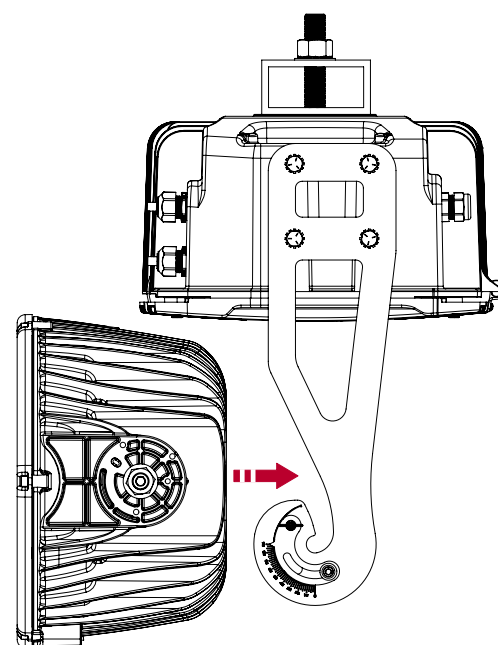

18b

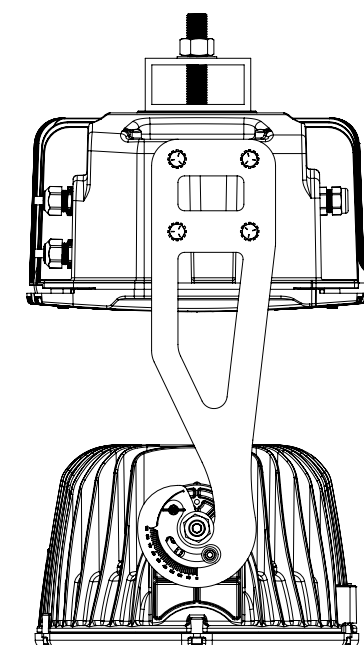

If laser aiming, tighten the light head nut so that fixture is secure but do not fully torque hardware until final aiming is complete.

If using the tilt gage, torque the light head nut to:

Hardware Description	Use / Location	Tool	After Aiming Torque	Quantity
5/8in-11 Nylock Nut	Light Head Mounting Nut	15/16in Socket	40 ft-lb	2X

Wire the Light Head to the Driver Box

Insert the Light Head cable into the Driver Box through the cord grip on the front left side of the Driver Box. Leave some slack in the cable to allow for aiming adjustments. Tighten cord grip hand tight and then tighten one additional revolution. The cable should not slide if the cable is pulled.

Yoke Mount

Note: Mounting infrastructure components removed for demonstrated clarity.

19a

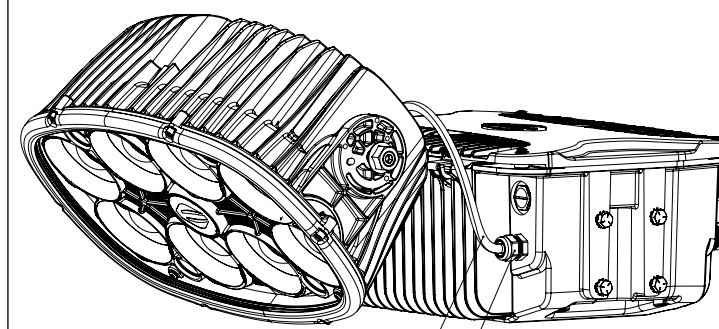

19b

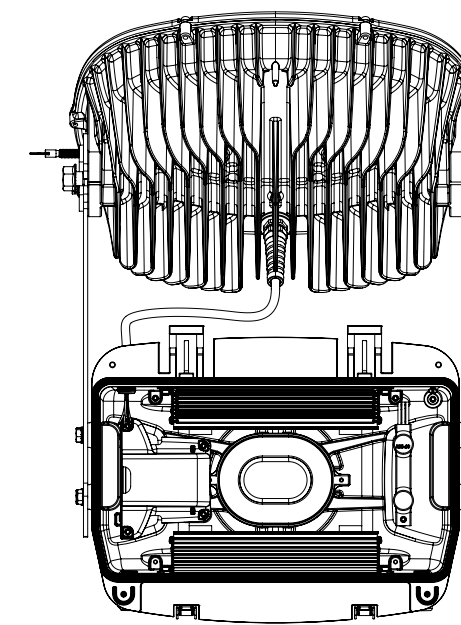



Pendant Mount

20

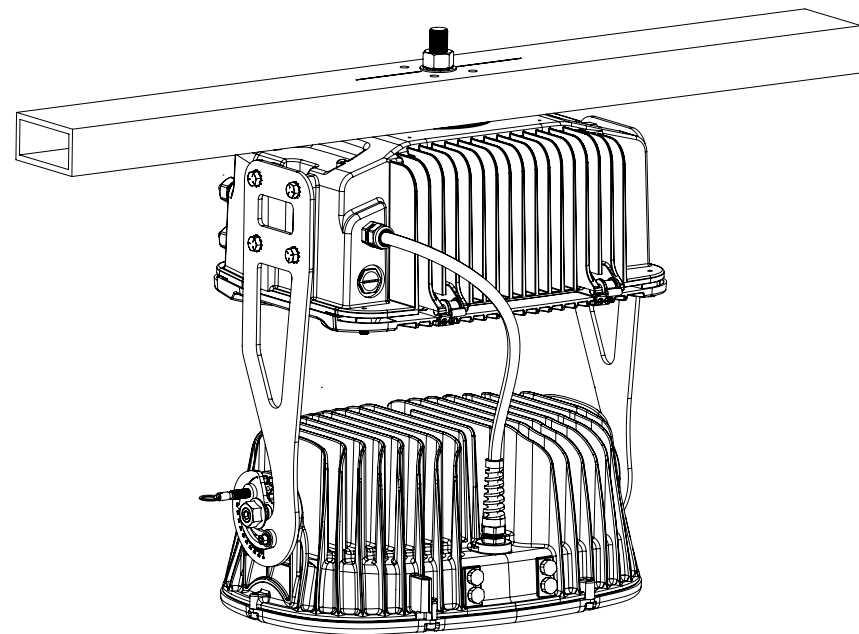

Connect the Light Head cable using the Wago connectors.

Light head Wire Color	Driver Box Wire Color	Designation	Comments
Light Green	Dark Green	Ground	
Light Blue	Dark Blue	DC Return	
Light Red	Dark Red	PSU 1	DC from Power Supply
Light Red	Dark Red	PSU 2	DC from second Power Supply (640W configurations)

LIGHTHEAD

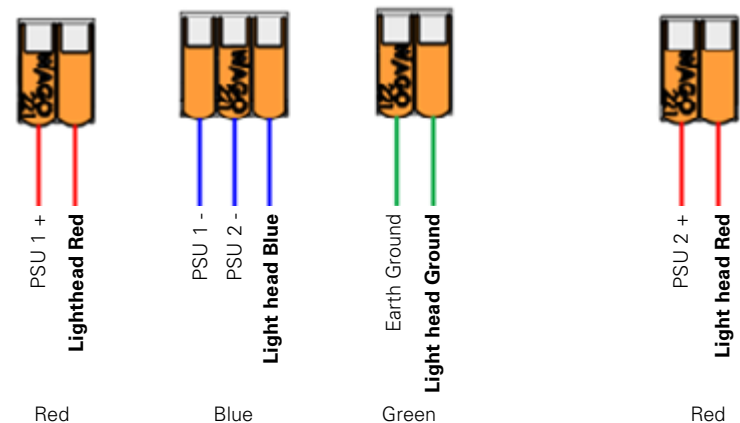

PSU 2 connections only apply to 640W models. The two red wires from the Light Head are interchangeable and may be connected to either Power Supply feed.



WARNING

Prevent access to area under fixture until laser aiming is completed.



Step 4 – Aiming

Laser Aiming

If fixture pre-aiming using the tilt and orient gages is satisfactory and laser aiming is not required, you can skip this step.

Refer to photometrics or project installation drawings for aiming point coordinates.

Slightly loosen the fixture aiming screws just enough to allow the fixture to rotate and tilt.

Insert the aiming mount onto the fixture aiming pin until it is fully seated tight against the fixture.



Do NOT over-loosen or remove set screw.

21a

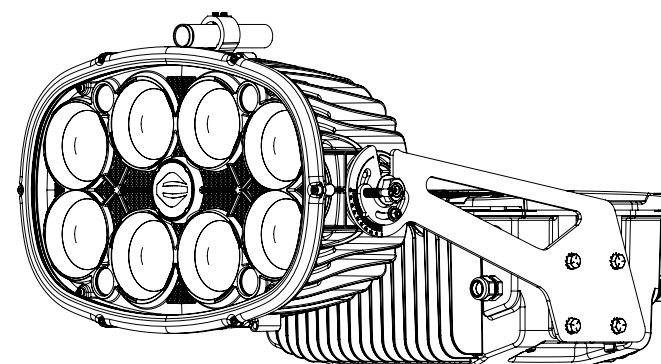

21b

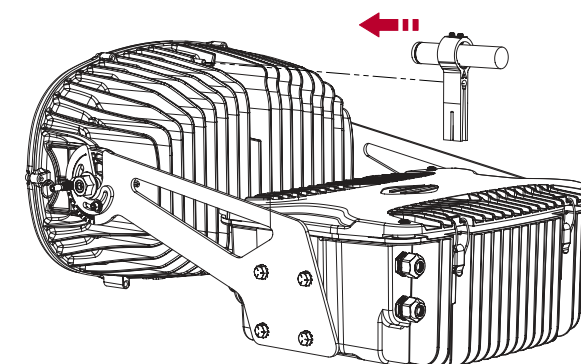

Turn on the laser and aim the fixture by targeting the laser dot at the aiming point.

Note: Turn off laser while not in use to conserve battery. Have spare battery charged to facilitate the aiming process.

Tighten All Hardware

After the fixture is aimed. Tighten all mounting and aiming hardware on the light head and driver box to the torques specified in the table below.

Hardware Description	Use / Location	Tool	Torque	Quantity
3/4in Mounting Bolt Assembly	Mounting Fixture To Mounting Structure	1-1/8in Socket	80 ft-lb	1X
3/8in-16 Locking Bolt Assembly	Orient Lock	9/16in Socket	20 ft-lb	1X
1/4in-20 Screw	Tilt Lock	3/16in Allen	75 in lbs	1X
5/8in-11 Nylock Nut	Light Head Mounting Nut	15/16in Socket	40 ft-lb	2X

If laser aiming, briefly turn the laser back on to verify that the luminaire aiming did not shift during tightening.

Remove the aiming mount from the fixture.



Step 5 – Final Steps

Final Inspection:

To complete the installation, verify that all mounting, connection, and aiming work is finished.

Before securing the driver box lid, verify all electrical connections are tight and secured. The installer is responsible for the integrity of all connections.

Verify all bolts and screws are tightened and properly torqued.

Straighten up all cabling. Tie down all cables neatly. For all outdoor projects, use UV rated tie wraps and wire management.

Close the Driver Box

Re-install the orange mounting hole cover over the mounting hole inside the Driver Box. Even in indoor applications, this cover should remain in place to keep dirt and debris out of the Driver Box.

Carefully push all wiring connections and lid straps (if applicable) inside the Driver Box and close the lid.



Make sure no wires are pinched in the cover.



Re-lock the bail latches. Tighten the captive driver box cover screws to:

Hardware Description	Use / Location	Tool	After Aiming Torque	Quantity
1/4in-20 Captive Screw	Driver Box Lid Screw	3/16in Allen	75 IN LBS	4X

22

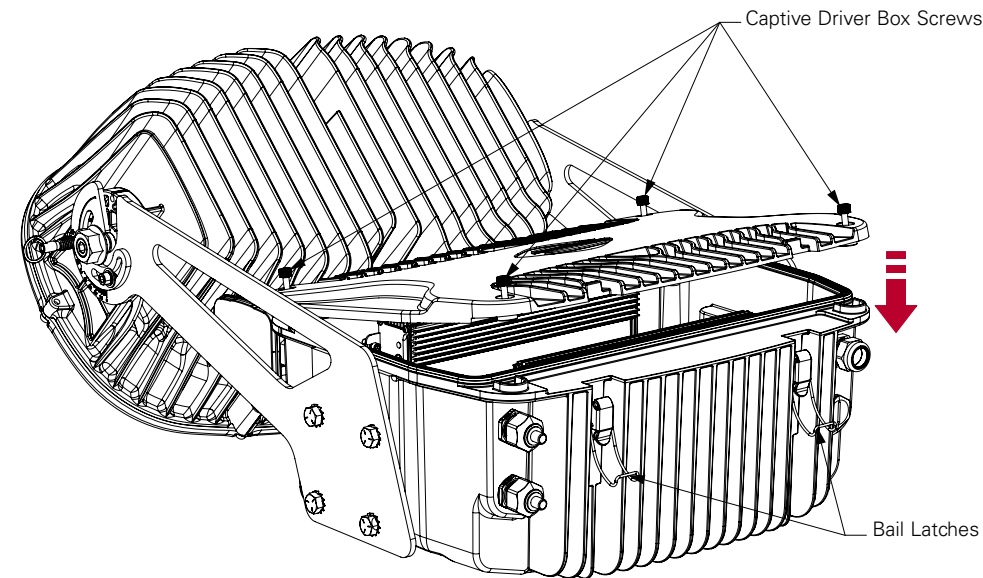

Install Secondary Retention

If required, install a secondary retention cable between the fixture and the supporting structure that is designed to support the weight of the fixture, such as the crossarm, catwalk railing, or beam. Route the cable through the cable port located on the bottom edge of the fixture, through the mounting bracket arm, and around the support structure.

Yoke Mount

23

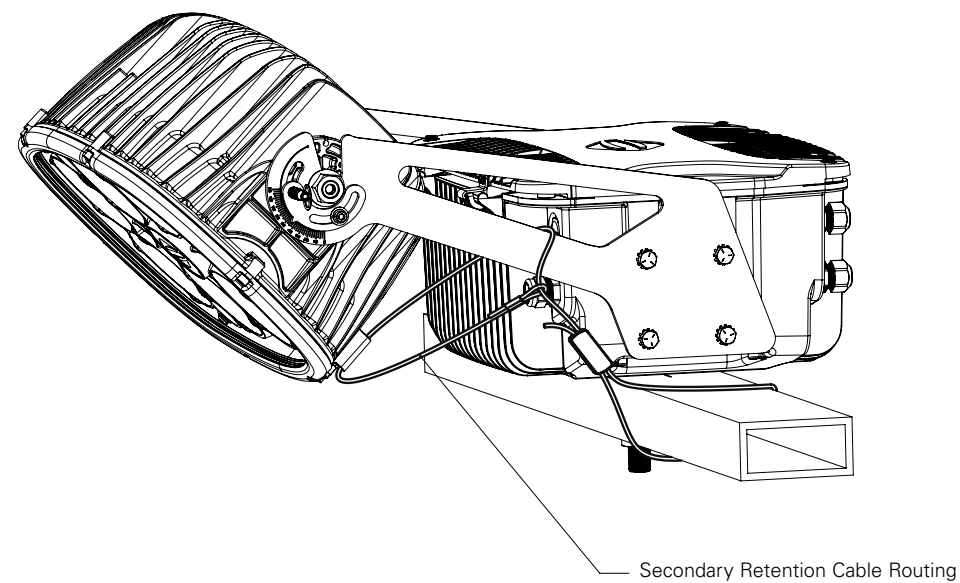

Pendant Mount

24

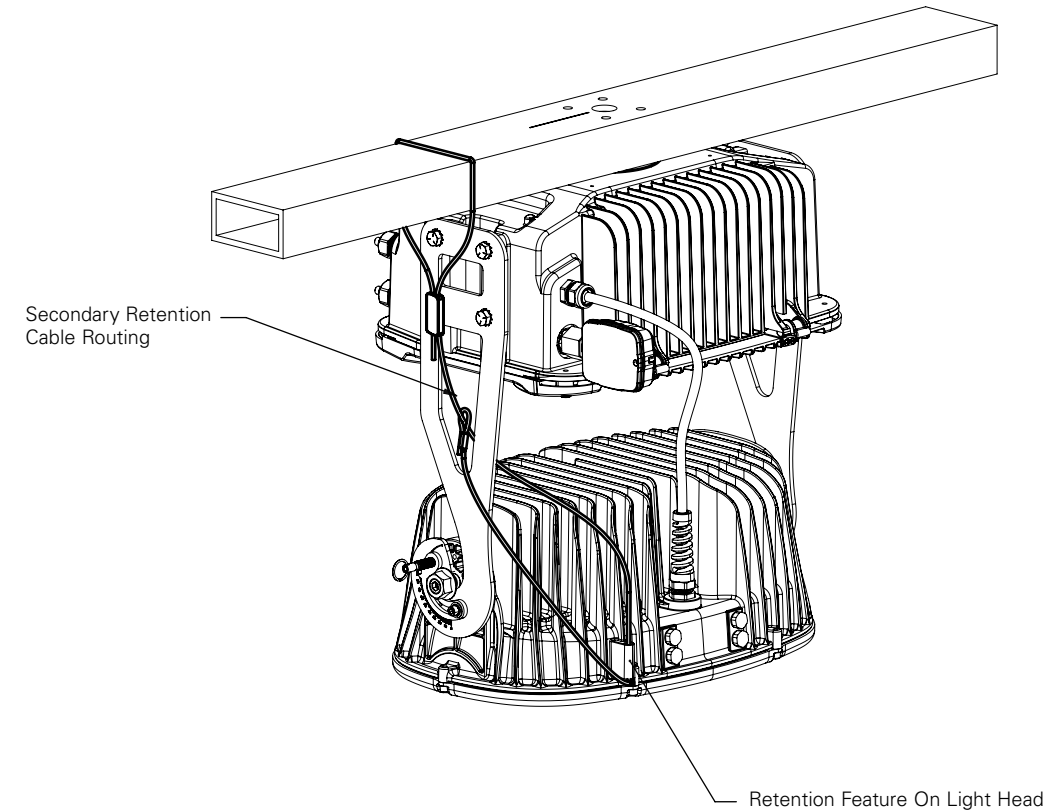

Note: Never secure the secondary retention cable to electrical conduits, power or HVAC equipment, other light fixtures, frangible material, or any other object not designed to support heavy loads.

Failure to properly install fixture and secondary retention cable may result in damage, injury or death.

Secure secondary retention cable to a structural component at a point above and directly behind the fixture if possible. Leave enough slack to allow fixture aiming if not completed, then pull extra slack through the locking clip after its aimed.

Recommended secondary retention cable is Gripple model #HF4-LT-10ft for indoor applications and equivalently sized vinyl coated cable with cable clamp for outdoor rated applications.



WARNING

Failure to properly install fixture and secondary retention cable may result in damage, injury or death.

Luminaire Operation

Default Response

LumaSport fixtures will turn on to 100% full on when the AC power is applied.

Control Details

For luminaires equipped with wired DMX or wireless AirMesh Hub control, the luminaire can be turned on, off or dimmed using a front-end control system.

For DMX control, the LumaSport takes a single DMX channel. The start address can be set by using an RDM (Remote Device Management) tool such as DMXCat or front-end controls. DMX start addresses can be set as desired per project.

Basic Functionality

When initial AC power is applied, the luminaires may have a fraction of a second delay and appear staggered for banks of lights.

The minimum light output on the fixtures is 10%. Therefore, the dimming range is 0, 10%-100%. A slight jump in light output may be perceived when dimmed up from blackout.

Advanced Functionality

It is recommended that advanced or fast dynamic scenes are controlled up from blackout to a value greater than 40% and have a delay longer than 100ms between transitions. Strobe, chase or other synchronized dynamic scenes may appear staggered when the luminaire is controlled up from blackout to a value less than 40% or transition faster than 100ms.

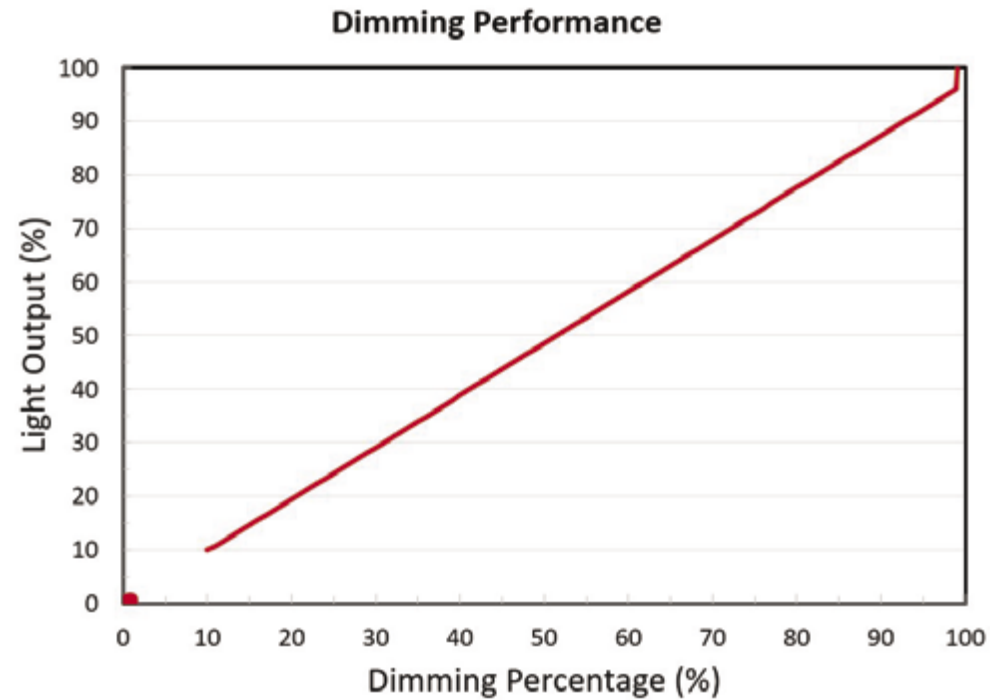

Maintenance & Preventative Maintenance

Fixture Care and Maintenance

All luminaires are prepared with a powder-coated finish. The finish on exterior luminaires may weather over time, depending on the environmental conditions at the installation site. Proper care of the luminaires will maintain their performance and appearance.

Follow a regular maintenance schedule to retain optimal light output and thermal performance. Lack of preventative maintenance may disqualify owner from warranty. Not adhering to this minimum system cleaning requirement is considered negligence as outlined in your product warranty documents. Refer to your product and/or labor warranty documentation for further details.

Cleaning

1. Clean all luminaires at a minimum of once every 12 months from receipt of your product.
2. Remove physical elements such as dirt, leaves and other foreign debris from the luminaire housing that can block and modify the air cooling (heatsink fins)
3. Wipe the optical lenses with a clean, dry, cotton cloth to remove dust and other contaminants. A non-abrasive optical cleanser or water may be used periodically.
4. Do not apply cleaners in direct sunlight or at elevated temperatures

Inspection of Hardware

Inspect mounting system and products at least once every 12 months. Replace all rusted hardware elements.



Troubleshooting

The Ephesus luminaire is designed to provide many years of reliable quality lighting. If the system appears to not be operating correctly, perform the following steps:

Gather Data

The first step is always to find out as much about the issue as possible. Ask the following questions:

1. **How many fixtures are not operating correctly?** If only one fixture is not responding, continue investigating at that fixture itself. If a group of fixtures are not responding correctly, start at the source of the power or controls for that group.
2. **Have any obvious external forces been in the area?** For instance, were any riggers, electricians, or other workers near the fixtures or controls? Have there been any power disturbances in the facility such as lightning storms?
3. **Are your fixtures responding according to the input control function?** Run the system through some different control scenes, including all on and then all off (blackout mode). Take note of any fixtures not responding correctly to the scenes.



WARNING

Always disconnect power from the luminaire before opening the driver box.

Problem	Remedy
Luminaire does not power on	<ul style="list-style-type: none"> • Verify the power supply is on, at the proper voltage, and stable. • Check connections at the source and at the fixture. • Verify control signal is above 50%.
Luminaire does not respond to controls	<ul style="list-style-type: none"> • Reset the fixture by turning all power sources off for at least 10 seconds. • Inspect all system control wiring to make sure there are no poor connections or breaks in the control wiring.

Fixture Replacement

Contacting Warranty Technical Support

1. Before you call, make sure you have completed the troubleshooting steps.
2. Gather as much detailed information as possible about the situation.
3. Have your fixture and project information handy, including the model number of the fixture in question.

Refer to your fixture warranty document for more information

If you have attic stock fixtures available and need to replace a fixture, simply follow the installation instructions in this manual to replace the fixture in question. Be sure to address the replacement fixture with the correct luminaire number.

All Luminaires, materials, and accessory equipment being returned through the warranty process need to be placed back in their original packaging in the same orientation that they were originally shipped from the factory. If the packaging is damaged or if there are questions on the orientation in returning equipment and materials, you need to contact the Warranty Department for replacement packaging materials at:

EphesusWarranty@Signify.com | +1 (800)-573-3600



**CLICK OR SCAN
FOR WARRANTY
INFORMATION
& CLAIM FORM**

Warranties and Limitation of Liability

Please refer to www.cooperlighting.com/global/resources/legal for our terms and conditions.